

# SERVICE MANUAL

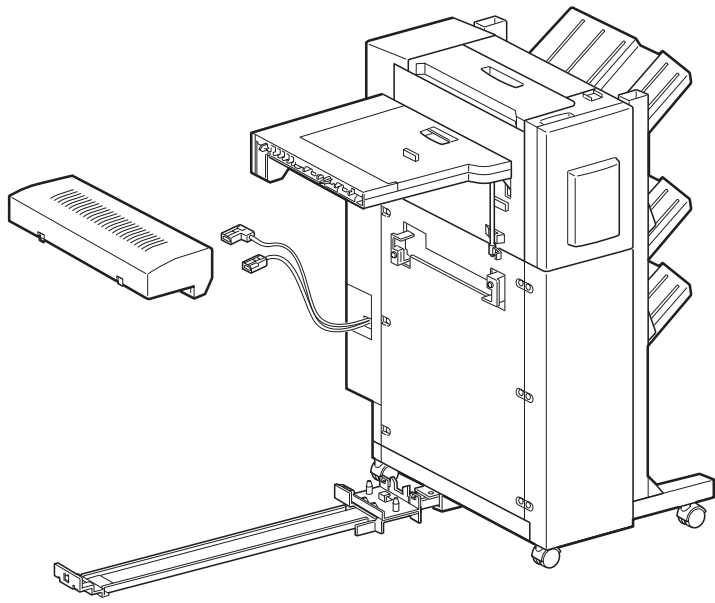

SSH010F

EPSON EPL-N4000/EPL-N4000+  
**OPTIONAL FINISHER STAPLER**



**EPSON®**

## Notice

- ❑ All rights reserved. No part of this manual may be reproduced, stored in a retrieval system, or transmitted in any form or by any means electronic, mechanical, photocopying, or otherwise, without the prior written permission of SEIKO EPSON CORPORATION.
- ❑ All effort have been made to ensure the accuracy of the contents of this manual. However, should any errors be detected, SEIKO EPSON would greatly appreciate being informed of them.
- ❑ The contents of this manual are subject to change without notice.
- ❑ All effort have been made to ensure the accuracy of the contents of this manual. However, should any errors be detected, SEIKO EPSON would greatly appreciate being informed of them.
- ❑ The above notwithstanding SEIKO EPSON CORPORATION can assume no responsibility for any errors in this manual or the consequences thereof.

EPSON is a registered trademark of SEIKO EPSON CORPORATION.

*General Notice: Other product names used herein are for identification purpose only and may be trademarks or registered trademarks of their respective owners. EPSON disclaims any and all rights in those marks.*

# PRECAUTIONS

Precautionary notations throughout the text are categorized relative to 1) Personal injury and 2) damage to equipment.

**DANGER** Signals a precaution which, if ignored, could result in serious or fatal personal injury. Great caution should be exercised in performing procedures preceded by DANGER Headings.

**WARNING** Signals a precaution which, if ignored, could result in damage to equipment.

The precautionary measures itemized below should always be observed when performing repair/maintenance procedures.

## **DANGER**

1. ALWAYS DISCONNECT THE PRODUCT FROM THE POWER SOURCE AND PERIPHERAL DEVICES PERFORMING ANY MAINTENANCE OR REPAIR PROCEDURES.
2. NO WORK SHOULD BE PERFORMED ON THE UNIT BY PERSONS UNFAMILIAR WITH BASIC SAFETY MEASURES AS DICTATED FOR ALL ELECTRONICS TECHNICIANS IN THEIR LINE OF WORK.
3. WHEN PERFORMING TESTING AS DICTATED WITHIN THIS MANUAL, DO NOT CONNECT THE UNIT TO A POWER SOURCE UNTIL INSTRUCTED TO DO SO. WHEN THE POWER SUPPLY CABLE MUST BE CONNECTED, USE EXTREME CAUTION IN WORKING ON POWER SUPPLY AND OTHER ELECTRONIC COMPONENTS.

## **WARNING**

1. REPAIRS ON EPSON PRODUCT SHOULD BE PERFORMED ONLY BY AN EPSON CERTIFIED REPAIR TECHNICIAN.
2. MAKE CERTAIN THAT THE SOURCE VOLTAGES IS THE SAME AS THE RATED VOLTAGE, LISTED ON THE SERIAL NUMBER/RATING PLATE. IF THE EPSON PRODUCT HAS A PRIMARY AC RATING DIFFERENT FROM AVAILABLE POWER SOURCE, DO NOT CONNECT IT TO THE POWER SOURCE.
3. ALWAYS VERIFY THAT THE EPSON PRODUCT HAS BEEN DISCONNECTED FROM THE POWER SOURCE BEFORE REMOVING OR REPLACING PRINTED CIRCUIT BOARDS AND/OR INDIVIDUAL CHIPS.
4. IN ORDER TO PROTECT SENSITIVE MICROPROCESSORS AND CIRCUITRY, USE STATIC DISCHARGE EQUIPMENT, SUCH AS ANTI-STATIC WRIST STRAPS, WHEN ACCESSING INTERNAL COMPONENTS.
5. REPLACE MALFUNCTIONING COMPONENTS ONLY WITH THOSE COMPONENTS BY THE MANUFACTURE; INTRODUCTION OF SECOND-SOURCE ICs OR OTHER NONAPPROVED COMPONENTS MAY DAMAGE THE PRODUCT AND VOID ANY APPLICABLE EPSON WARRANTY.

# About This Manual

This manual describes basic functions, theory of electrical and mechanical operations, and repair procedures of EPL-N4000/N-400+ Optional Finisher Stapler. The instructions and procedures included herein are intended for the experienced repair technicians, and attention should be given to the precautions on the preceding page.

## Contents

This manual consists of three chapters and Appendix.

### **CHAPTER 1. PRODUCT DESCRIPTIONS**

Provides a general overview and specifications of the product.

### **CHAPTER 2. OPERATING PRINCIPLES**

Describes the theory of electrical and mechanical operations of the product.

### **CHAPTER 3. DISASSEMBLY AND ASSEMBLY**

Describes the step-by-step procedures for disassembling and assembling the product.

**APPENDIX** Provides the following additional information for reference:

- Connector pin assignments
- Electric circuit boards components layout
- Exploded diagram

## Symbols Used in This Manual

Various symbols are used throughout this manual either to provide additional information on a specific topic or to warn of possible danger present during a procedure or an action. Be aware of all symbols when they are used, and always read WARNING, CAUTION or NOTE messages.



Indicates an operating or maintenance procedure, practice or condition that, if not strictly observed, could result in injury or loss of life.



Indicates an operating or maintenance procedure, practice, or condition that, if not strictly observed, could result in damage to, or destruction of, equipment.



May indicate an operating or maintenance procedure, practice or condition that is necessary to accomplish a task efficiently. It may also provide additional information that is related to a specific subject, or comment on the results achieved through a previous action.



# Contents

## *Product Description*

---

Outline .....	12
General Specification (TBD) .....	12
Stapler Specification (TBD) .....	12
Compiler Specification (TBD) .....	12
Stacker Specification (TBD) .....	12
Offset Specification (TBD) .....	13

## *Operating Principles*

---

Power Supply .....	15
Control over the Finisher Stapler .....	15
Control Main Parts of the Finisher Stapler .....	16
Transport .....	16
Compiler .....	16
Stapler .....	17
Eject and Offset .....	18
Stacker Unit .....	18
Stacker Top Tray .....	18
Stacker Middle Tray .....	19
Stacker Bottom Tray .....	19
Transmission of the Driving Force .....	20
Transport Motor .....	20
Eject Motor .....	20
End Wall Motor .....	21
Tamper Motor .....	21
Set Clamp Motor .....	22
Offset Motor .....	22
Stacker Elevator Motor .....	23
Tray Motors .....	24
Paper Path .....	25
Paper Path on the Unstaple Mode .....	25
DOC .....	25

Transport .....	26
Exit/Eject .....	26
Stacker Trays .....	27
Paper Path on the Staple Mode .....	27
DOC .....	27
Transport .....	27
Exit/Eject .....	28
Compiler/Tamper .....	28
Stapler .....	29
Eject/Offset .....	30
Stacker Trays .....	31

## *Disassembly and Assembly*

---

Outline .....	33
Preparation .....	33
Attention for Handling .....	33
Notation for Removal and Installation .....	33
Up and Down of Finisher Stapler .....	34
Installation and Removal of Finisher Stapler and Stapler Cartridge .....	35
Finisher Stapler .....	35
Installation .....	35
Removal .....	37
Installing and Replacing Stapler Cartridge .....	38
Replacing the Stapler Cartridge .....	39
Disassembly and Assembly .....	40
Front Cover Assembly .....	40
Removal .....	40
Installation .....	40
Front Cover Inner Assembly .....	41
Removal .....	41
Installation .....	41
Front Low Cover .....	42
Removal .....	42

Installation .....	42	Bottom (Lower) Tray Assembly .....	57
L/H Cover .....	43	Removal .....	57
Removal .....	43	Installation .....	57
Installation .....	43	Bottom Tray Front Cover .....	58
L/H Cover Low .....	44	Removal .....	58
Removal .....	44	Installation .....	58
Installation .....	44	Bottom Tray Half and Full Sensors .....	59
Eject Cover .....	45	Removal .....	59
Removal .....	45	Installation .....	59
Installation .....	45	Bottom Tray Lower and Upper Limit Sensor .....	60
Rear Cover .....	46	Removal .....	60
Removal .....	46	Installation .....	60
Installation .....	46	Bottom Tray .....	61
Harness Cover .....	46	Removal .....	61
Removal .....	46	Installation .....	61
Installation .....	46	Bottom Tray Paper Sensor .....	62
Add Cover .....	47	Removal .....	62
Removal .....	47	Installation .....	62
Installation .....	47	Bottom Tray Safety Sensor .....	63
Finisher Stapler PWB Cover and Connector Cover .....	48	Removal .....	63
Removal .....	48	Installation .....	63
Installation .....	48	Bottom Tray Motor .....	64
Stacker Upper Limit Switch .....	50	Removal .....	64
Removal .....	50	Installation .....	64
Installation .....	50	Bottom Tray Drive Belts .....	65
Stacker Lower Limit Switch .....	51	Removal .....	65
Removal .....	51	Installation .....	66
Installation .....	51	Middle Tray Assembly .....	67
Finisher Stapler Interlock Sensor and Actuator .....	52	Removal .....	67
Removal .....	52	Installation .....	67
Installation .....	52	Middle Tray Front Cover .....	68
Stacker Tray ID Sensor .....	53	Removal .....	68
Removal .....	53	Installation .....	68
Installation .....	53	Middle Tray Half and Full Sensors .....	69
R/H Rack Cover Assembly .....	54	Removal .....	69
Removal .....	54	Installation .....	69
Installation .....	55	Middle Tray Lower and Upper Limit Sensor .....	70
Stacker Elevator Motor .....	56	Removal .....	70
Removal .....	56	Installation .....	70
Installation .....	56	Middle Tray .....	71

Removal .....	71	Installation .....	86
Installation .....	71	Tamper Motor .....	87
Middle Tray Paper Sensor .....	72	Removal .....	87
Removal .....	72	Installation .....	87
Installation .....	72	Tamper Home Sensor .....	88
Middle Tray Motor .....	73	Removal .....	88
Removal .....	73	Installation .....	88
Installation .....	73	Compiler Paper Sensor .....	89
Middle Tray Drive Belts .....	74	Removal .....	89
Removal .....	74	Installation .....	89
Installation .....	75	End Wall Open Sensor .....	90
Middle Tray Safety Switch .....	76	Removal .....	90
Removal .....	76	Installation .....	90
Installation .....	76	Tamper Motor Drive Belt .....	91
Top Tray Assembly .....	77	Removal .....	91
Removal .....	77	Installation .....	91
Installation .....	77	Compiler Tray Solenoid Assembly .....	92
Top Tray Front Cover .....	78	Removal .....	92
Removal .....	78	Installation .....	92
Installation .....	78	Eject Shaft Assemblies .....	93
Top Tray Half and Full Sensors .....	79	Removal .....	93
Removal .....	79	Installation .....	93
Installation .....	79	Upper Exit Chute Assembly .....	95
Top Tray Lower and Upper Limit Sensor .....	80	Removal .....	95
Removal .....	80	Installation .....	95
Installation .....	80	Exit Shaft Assembly .....	96
Top Tray .....	81	Removal .....	96
Removal .....	81	Installation .....	96
Installation .....	81	Paddle Shaft Assembly .....	97
Top Tray Paper Sensor .....	82	Removal .....	97
Removal .....	82	Installation .....	98
Installation .....	82	Eject Chute Assembly .....	99
Top Tray Motor .....	83	Removal .....	99
Removal .....	83	Installation .....	99
Installation .....	83	Eject Pinch Roll Shaft Assembly .....	100
Top Tray Drive Belts .....	84	Removal .....	100
Removal .....	84	Installation .....	100
Installation .....	85	Stack Height Sensor .....	101
Top Tray Safety Switch .....	86	Removal .....	101
Removal .....	86	Installation .....	101



Paddle Drive Belt .....	102	Removal .....	116
Removal .....	102	Installation .....	116
Installation .....	102	Eject Motor .....	117
Stapler Assembly .....	103	Removal .....	117
Removal .....	103	Installation .....	117
Installation .....	103	Stapler Transport Motor .....	118
Stapler Position Sensors .....	104	Removal .....	118
Removal .....	104	Installation .....	118
Installation .....	104	Stapler Transport Motor Drive Belt .....	119
Top Cover Assembly .....	105	Removal .....	119
Removal .....	105	Installation .....	119
Installation .....	105	Transport Motor Drive Belt .....	120
Compiler Tray Exit Sensor .....	106	Removal .....	120
Removal .....	106	Installation .....	120
Installation .....	106	Eject Bracket Assembly .....	121
Upper Transport Chute Assembly .....	107	Removal .....	121
Removal .....	107	Installation .....	121
Installation .....	107	Eject Clamp Offset Motor .....	122
Top and Front Cover Interlock Switches .....	108	Removal .....	122
Removal .....	108	Installation .....	122
Installation .....	108	Eject Clamp Sensor .....	123
Compiler Cover and Safety Interlock Switches .....	109	Removal .....	123
Removal .....	109	Installation .....	123
Installation .....	110	Offset Home Sensor .....	124
Unload While Run Switch .....	111	Removal .....	124
Removal .....	111	Installation .....	124
Installation .....	111	Finisher Stapler PWB Assembly .....	125
End Wall Motor .....	112	Removal .....	125
Removal .....	112	Installation .....	125
Installation .....	113	LVPS (OP11/OPR4H) .....	126
Transport Motor .....	114	Removal .....	126
Removal .....	114	Installation .....	126
Installation .....	114	DOC Cover Assembly .....	127
Set Clamp Motor .....	115	Removal .....	127
Removal .....	115	Installation .....	127
Installation .....	115	IN Gate Support Assembly .....	128
Set Clamp Motor Drive Belt .....	116	Removal .....	128
Removal .....	116	Installation .....	128
Installation .....	116	IN Gate Support Actuator .....	129
Set Clamp Home Sensor .....	116	Removal .....	129

Installation .....	129
Transport Assembly .....	130
Removal .....	130
Installation .....	130
Transport Assembly Drive Belt .....	131
Removal .....	131
Installation .....	132
IN Gate Interlock Switch .....	133
Removal .....	133
Installation .....	133
IN Gate Solenoid Assembly .....	134
Removal .....	134
Installation .....	134
Roller Unit .....	135
Removal .....	135
Installation .....	135
Transport Cover Assembly .....	136
Removal .....	136
Installation .....	136
Transport Interlock Sensor .....	137
Removal .....	137
Installation .....	137
Transport Roll .....	138
Removal .....	138
Installation .....	138
Transport Entrance Sensor .....	140
Removal .....	140
Installation .....	140
IOT Paper Full Sensor .....	141
Removal .....	141
Installation .....	141
Transport Exit Sensor .....	142
Removal .....	142
Installation .....	142

Exploded Diagram and Parts List .....	165
HCS Transport .....	165
HCS Covers Front .....	166
HCS Covers Rear .....	167
Rack .....	168
Rails and Trays .....	169
Lower Tray .....	171
Lower Tray Frame .....	173
Middle Tray .....	174
Middle Tray Frame .....	176
Top Tray .....	178
Top Tray Frame .....	180
Tray Eject .....	181
Exit .....	183
Offset and Eject .....	184
Stapler .....	185
Transport .....	186
Front Frame .....	187
Rear Frame 1 .....	188
Rear Frame 2 .....	189
Rear Frame 3 .....	190
Electrical Module .....	191
Harness .....	192
HCS DOC .....	193
Frame Transport, Rear .....	194
Frame Transport, Open .....	195

**Appendix**

Wiring Diagram and Signal Data .....	144
Connector .....	154
P/J Connector Table and Location Map .....	154

CHAPTER

1

**PRODUCT DESCRIPTION**

## 1.1 Outline

---

This chapter describes the specification of the Finisher Stapler.

### 1.1.1 General Specification (TBD)

---

#### STRUCTURE

---

Finisher Stapler is the option of the EPSON EPL-N4000/EPL-N4000+. It consists of horizontal transport unit and stack tray unit. Horizontal transport unit is installed to the face down output tray of the printer, and stack tray is installed to the right side of the printer.

**NOTE:** Finisher Stapler cannot be used with 10 pin multipin.

#### FUNCTION

---

- Stapling at the specified position.
- Three ejecting paper stack trays

#### PAPER

---

Refer to product specification for EPSON EPL-N4000/EPL-N4000+.

#### ELECTRIC POWER CONSUMPTION (TBD)

---

55W (110VAC)

#### NOISE (TBD)

---

Continuous noise on the job: max. 72.8dB

#### SIZE AND WEIGHT

---

- Dimensions:1,133 x 633 x 658 mm (HxWxD)
- Weight:58kg

### 1.1.2 Stapler Specification (TBD)

---

#### STAPLE (TBD)

---

- Maximum amount of paper:50 sheets (paper: Xerox DP 20lb)
- Staple position:Front, Rear (Corner), Rear (Straight), Multiple staple

#### STAPLE CARTRIDGE (TBD)

---

5000 staples

### 1.1.3 Compiler Specification (TBD)

---

#### COMPILER

---

Ejected paper is stacked on the Compiler Tray, jogged by the tamper to the front, and sent to the Stacker.

#### MAXIMUM SETTABLE AMOUNT OF PAPER

---

50 sheets

#### MINIMUM PAPER WIDTH

---

210mm

### 1.1.4 Stacker Specification (TBD)

---

#### STACKER

---

Tray: 3

---

**PAPER CAPACITY**

---

- Without Staple:500 sheets/tray
- With staple:Max. 30 sets or 600 sheets/tray
  - Real Staple Mode:15 sheets (B5 LEF, B5, B4 SEF)
  - Multiple Staple Mode:15 sheets (B5, SEF)

**NOTE:** LEF= Long Edge First, SEF= Short Edge First

### 1.1.5 Offset Specification (TBD)

---

**OFFSET (TBD)**

---

By shifting the ejecting roller, the Finisher Stapler can eject paper 15mm offset.

CHAPTER

2

**OPERATING PRINCIPLES**

## 2.1 Power Supply

The Power Supply of the Finisher Stapler is supplied by the 100V AC via the printer and generated by the LVP PWB in the Finisher Stapler.

### 2.1.1 Control over the Finisher Stapler

LVPS sends the sensor data in the Finisher Stapler to the MCU of the printer. Commands from the MCU of the printer is transferred to the Finisher PWB and controls over respective components of the Finisher Stapler.

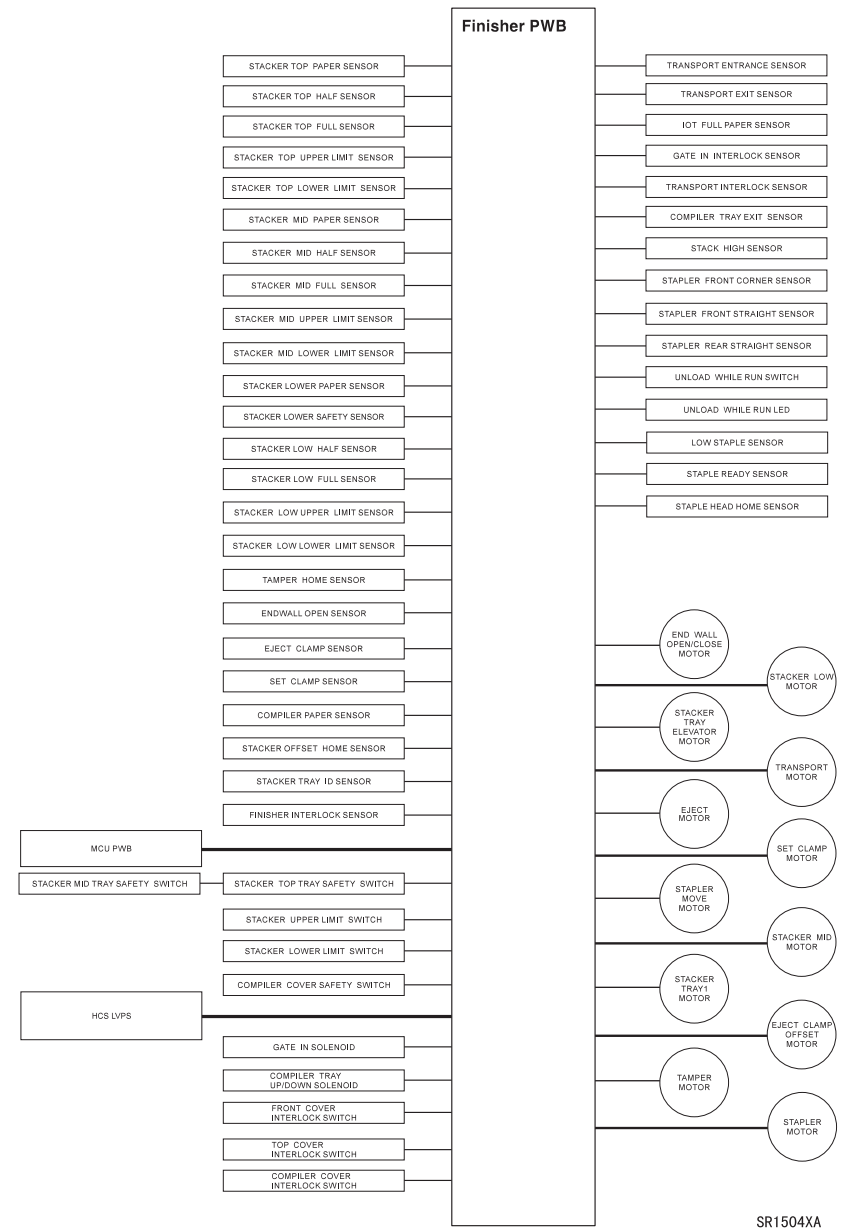

Figure 2-1. Components

## 2.1.2 Control Main Parts of the Finisher Stapler

- ❑ Finisher PWB  
LVPS PWB sends sensor data in the Finisher Stapler to MCU of the printer. Commands from the MCU of the base engine is transferred to the Finisher PWB and controls over respective components of the Finisher Stapler.
- ❑ HCS Low Voltage Power Supply  
Generates +5VDC and +24VDC from 100VAC.
- ❑ Unload While Run Switch and LED  
This switch is for user to interrupt Finisher Stapler when it is proceeding its job.  
LED flashes when interruption is made.
- ❑ Finisher Interlock Sensor  
Supervises that the door of the Finisher Stapler is not open.
- ❑ Front Cover Interlock Switch  
When Front Cover is open, shut off 24VDC.
- ❑ Compiler Cover Safety Switch  
When Compiler Cover is open, shut off 24VDC.
- ❑ Top Tray Safety Switch  
Detects if there are any obstructions under the Top Tray and shut off +24VDC and stop the Elevator Motor.
- ❑ Middle Tray Safety Switch  
Detects if there are any obstructions under the Middle Tray and shut off +24VDC and stop the Elevator Motor. Top Tray Safety Switch and Middle Tray Safety Switch are connected in series.

### 2.1.2.1 Transport

Shift paper from DDC to Compiler.

- ❑ IN Gate Solenoid  
Alternate the direction of IN Gate.
- ❑ IN Gate Interlock Sensor  
Supervises the position of IN Gate. (Up/Down)
- ❑ Transport Entrance Sensor  
Supervises paper passing to Transport Assembly.

- ❑ IOT Full Paper Sensor  
Supervises the amount of paper on the eject tray of the printer.
- ❑ Transport Exit Sensor  
Supervises paper passing from Transport Assembly.
- ❑ Transport Interlock Sensor  
Supervises the condition of the Transport Cover.
- ❑ Transport Motor  
Drives Transport Rolls.

### 2.1.2.2 Compiler

Compiler arranges paper as set.

- ❑ Tamper Motor  
Drives Tamper which pushes paper to the end.
- ❑ Tamper Home Sensor  
Supervises the position of the Tamper.

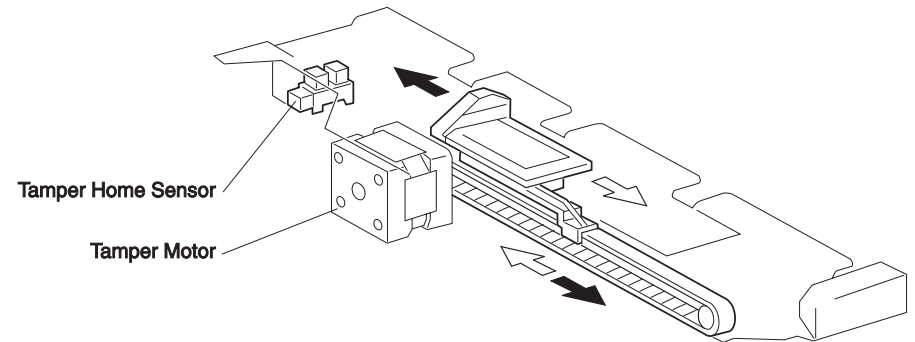

SR1506X

**Figure 2-2. Tamper/Tamper Home Sensor**

- ❑ Compiler Tray Up/Down Solenoid  
Slant Compiler Tray when the amount of paper has reached twenty five.



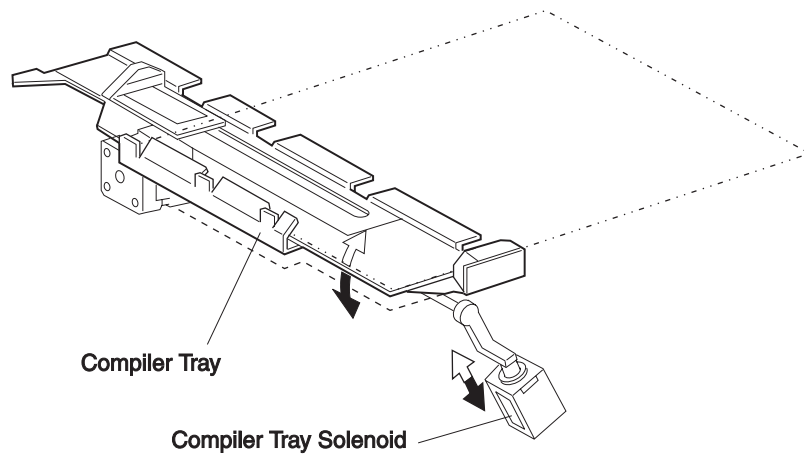

SR1505X

**Figure 2-3. Compiler Tray Up / Down Solenoid**

- End Wall Open/Close Motor  
Controls opening and closing of the End Wall.
- End Wall Open Sensor  
Supervises the position of the End Wall.
- Compiler Tray Exit Sensor  
Supervises paper ejecting through the entrance of the Compiler. HCS uses the signal from the sensor to determine start and stop of the Transport Motor and Eject Motor.
- Compiler Paper Sensor  
Supervises paper on the Compiler Tray.
- Compiler Cover Interlock Switch  
Supervises the position of the Compiler Cover.

### 2.1.2.3 Stapler

Stapler bundles paper with staple.

- Stapler Front Corner Sensor  
Commands the position where Stapler Unit staples at the front corner of paper.

- Stapler Front Straight Sensor  
Commands the position of the Stapler Unit as the Move Motor can drive Stapler until the Stapler Unit comes to the staple position at the front and rear edge of paper.
- Stapler Rear Straight Sensor  
Commands the position of the Stapler Unit as the Move Motor can drive Stapler until the Stapler Unit comes to the staple position at the rear corner of paper.
- Stapler Move Motor  
Shift the Stapler Head to the Staple position.

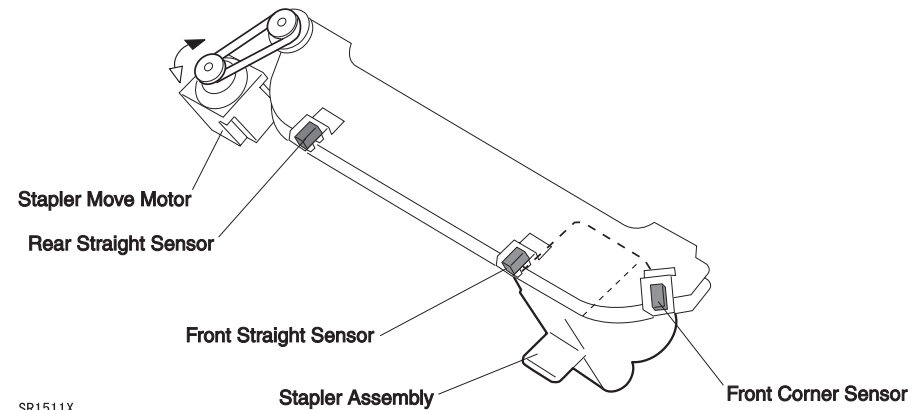

SR1511X

**Figure 2-4. Stapler / Sensors**

- Stapler Motor  
Drives Stapler Head during stapler stapling paper.
- Staple Ready Sensor  
Supervises the existence of the staple in Staple Head.
- Low Staple Sensor  
Supervises the remaining of the staple in Stapler.
- Stapler Head Home Sensor  
Supervises if the Stapler Head is at the home position.
- Set Clamp Home Sensor  
Supervises if the Set Clamp is at the home position.

- Set Clamp Motor  
Drives Set Clamp paddle to clamp paper on the Compiler Tray before stapling.

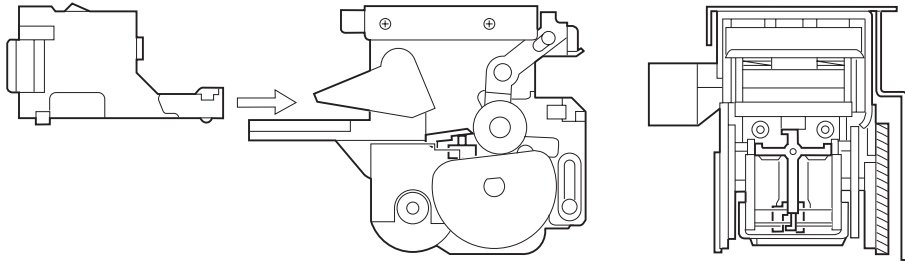

SER884F

**Figure 2-5. Stapler**

#### 2.1.2.4 Eject and Offset

Eject and Offset carries paper compiled on the Stacker Tray and ejects offset paper.

- Eject Clamp and Offset Motor  
Drives Eject Chute and Pinch Roll by shifting Eject Chute and Pinch Roll up and down.
- Eject Clamp Sensor  
Supervises if Eject Roll is at the upper position or at the lower position.
- Stacker Offset Home Sensor  
Supervises if Eject Roll is at the home position.
- Eject Motor  
Drives Eject Shaft Assembly.

#### 2.1.2.5 Stacker Unit

Provides function to shift three Stacker Tray up and down.

- Stacker Tray Elevator Motor  
Revolves Stacker Drive shaft clockwise or counterclockwise and shifts Stacker Tray up and down.
- Stacker Tray ID Sensor  
Supervises the right position of the Tray.
- Stacker Upper Limit Switch  
Detects the upper limit of the Stacker Tray. The switch shut off the DC power supply to the Elevator Motor.
- Stacker Lower Limit Switch  
Detects the lower limit of the Stacker Tray. The switch shut off the DC power supply to the Elevator Motor.
- Stacker Lower Safety Switch  
Supervises the obstruction under the Bottom Tray.
- Stack Height Sensor  
Supervises the Tray position.

#### 2.1.2.6 Stacker Top Tray

Provides function to shift Top Stacker Tray up and down.

- Stacker Tray 1 Motor  
Shifts Top Tray up and down.
- Stacker Top Paper Sensor  
Detects if there are paper on the Top Tray.
- Stacker Top Full Sensor  
Detects if paper on the Top Tray is full.
- Stacker Top Half Sensor  
Detects if paper on the Top Tray is 50% full.
- Stacker Top Upper Limit Sensor  
Detects the upper limit of the Top Tray. The sensor sends signal to Finisher Stacker PWB to shut off the DC power supply to the Stacker Tray 1 Motor.
- Stacker Top Lower Limit Sensor  
Detects the lower limit of the Top Tray. The sensor sends signal to Finisher Stacker PWB to shut off the DC power supply to the Stacker Tray 1 Motor.

### 2.1.2.7 Stacker Middle Tray

Provides function to shift Middle Stacker Tray up and down.

- Stacker Middle Motor  
Shifts Middle Tray up and down.
- Stacker Middle Paper Sensor  
Detects if there are paper on Middle Tray.
- Stacker Middle Full Sensor  
Detects if paper on Middle Tray is full.
- Stacker Middle Half Sensor  
Detects if paper on Middle Tray is 50% full.
- Stacker Middle Upper Limit Sensor  
Detects the upper limit of Middle Tray. The sensor sends signal to Finisher PWB to shut off the DC power supply to the Stacker Middle Motor.
- Stacker Middle Lower Limit Sensor  
Detects the lower limit of Middle Tray. The sensor sends signal to Finisher PWB to shut off the DC power supply to the Stacker Middle Motor.

- Stacker Low Lower Limit Sensor  
Detects the upper limit of Bottom Tray. The sensor sends signal to Finisher PWB to shut off the DC power supply to the Stacker Bottom Motor.

### 2.1.2.8 Stacker Bottom Tray

Provides function to shift Bottom Stacker Tray up and down.

- Stacker Low Motor  
Shifts the Bottom Tray up and down.
- Stacker Low Paper Sensor  
Detects if there are paper on the Bottom Tray.
- Stacker Low Full Sensor  
Detects if paper on the Bottom Tray is full.
- Stacker Low Half Sensor  
Detects if paper on the Bottom Tray is 50% full.
- Stacker Low Upper Limit Sensor  
Detects the upper limit of Bottom Tray. The sensor sends signal to Finisher PWB to shut off the DC power supply to the Stacker Bottom Motor.

## 2.2 Transmission of the Driving Force

### 2.2.1 Transport Motor

Transport Motor is in the Compiler of the Finisher Stapler.

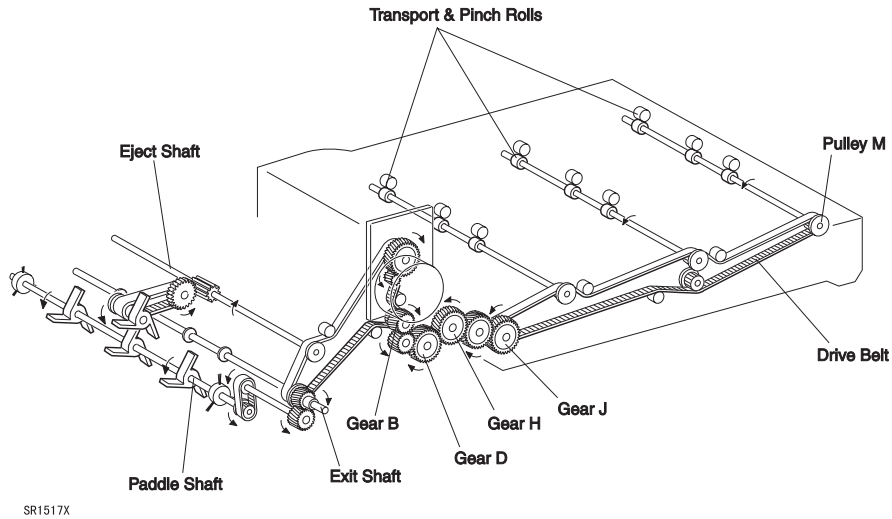

Figure 2-6. Transport Driving Mechanism

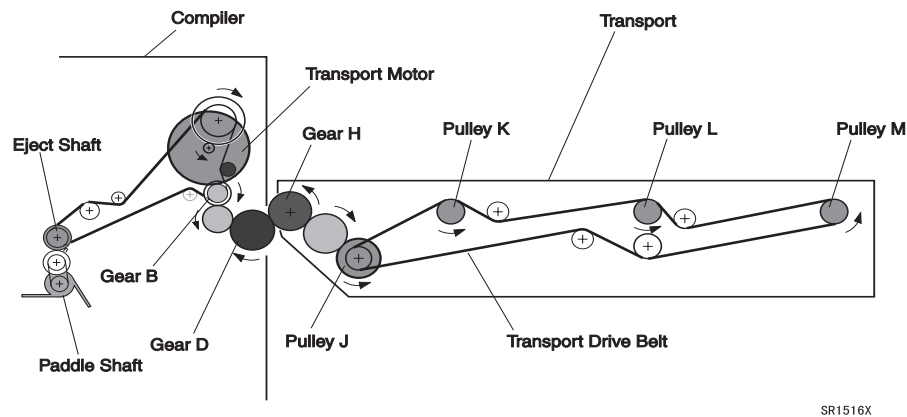

Figure 2-7. Driving Force Transmission Outline

### 2.2.2 Eject Motor

Finisher PWB revolves the Eject Motor clockwise to eject paper to the Stacker Tray. Finisher PWB also revolves the Eject Motor counterclockwise to pull paper back to the Compiler Tray.

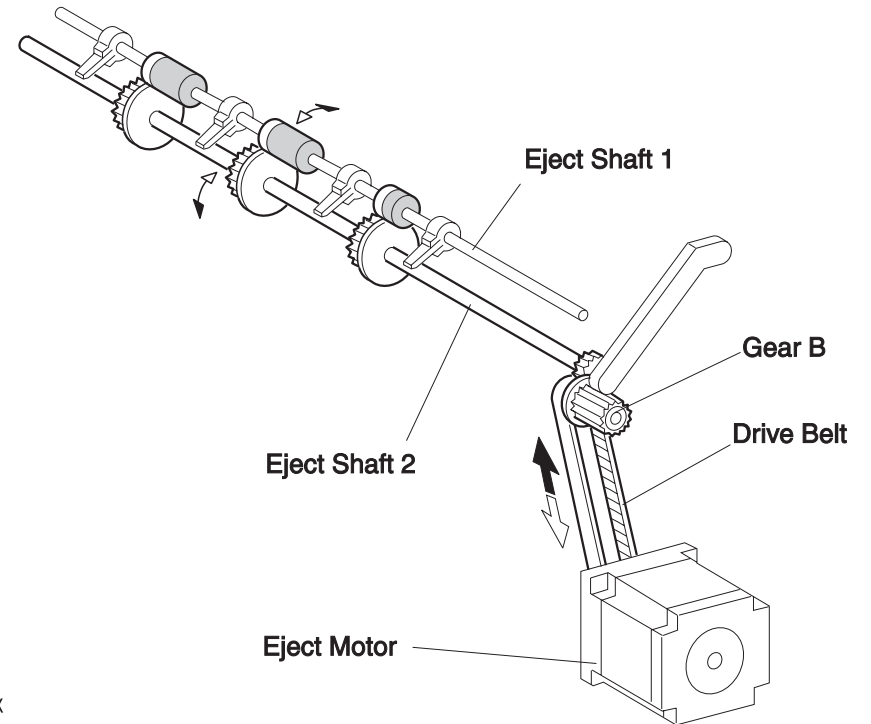
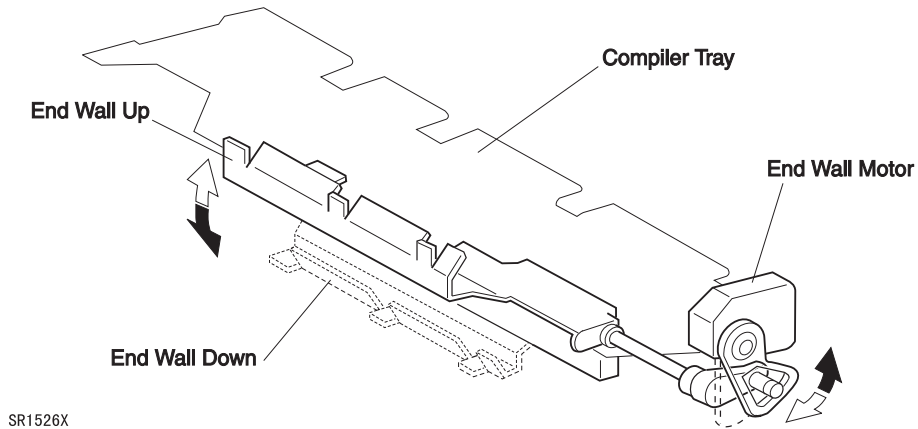

Figure 2-8. Eject Motor

### 2.2.3 End Wall Motor

End Wall Motor shifts the End Wall of the Compiler Tray. When paper is sent to the Compiler Tray, End Wall Motor shifts up the End Wall. When paper is stapled, End Wall Motor shifts down the End Wall.



SR1526X

Figure 2-9. End Wall Motor

### 2.2.4 Tamper Motor

Tamper Motor drives the Tamper.

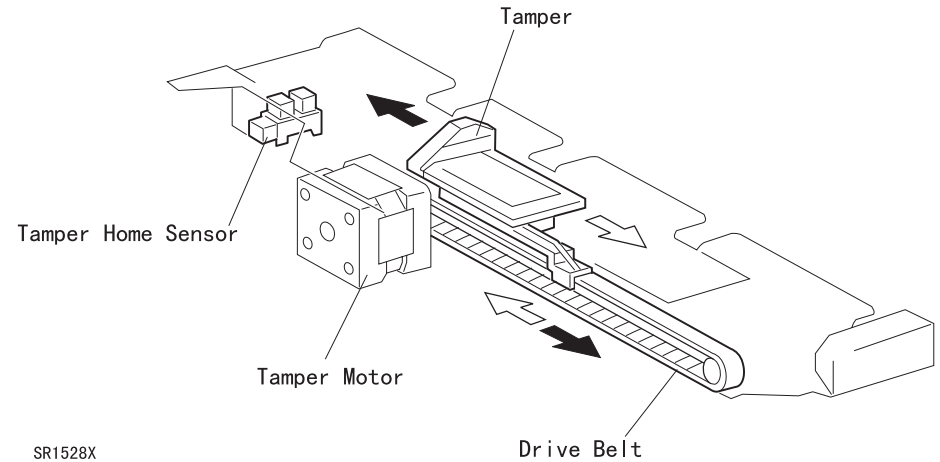

SR1528X

Figure 2-10. Tamper Motor Working Part

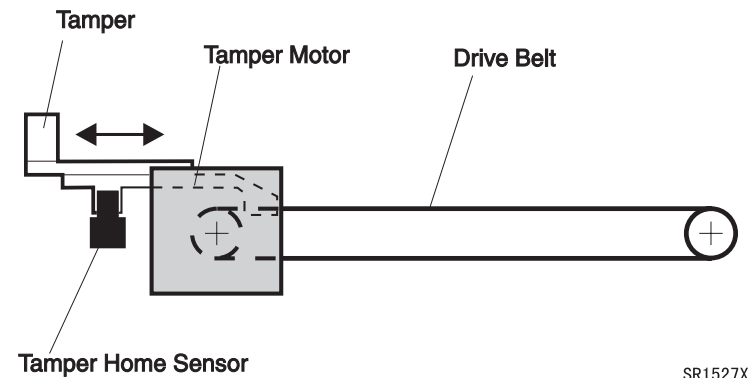

SR1527X

Figure 2-11. Tamper Motor Operational Outline

### 2.2.5 Set Clamp Motor

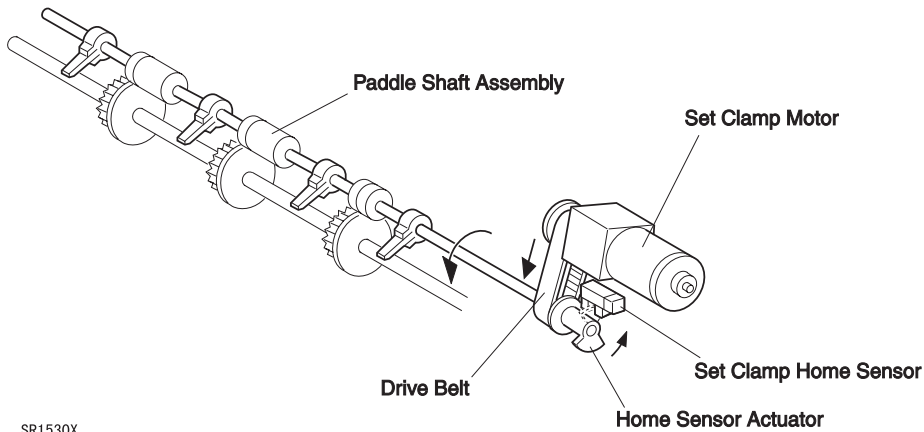

SR1530X

Figure 2-12. Set Clamp Motor Working Part

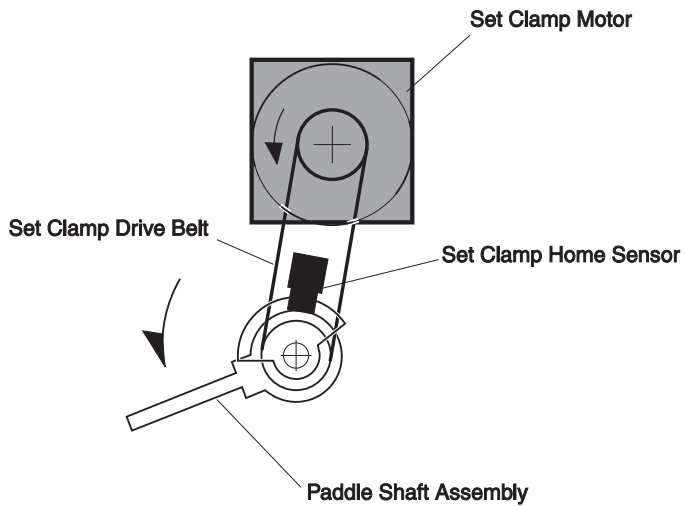

SR1529X

Figure 2-13. Set Clamp Motor Operational Outline

### 2.2.6 Offset Motor

Eject Clamp Offset Motor drives Offset Cam and Eject Clamp Cam.

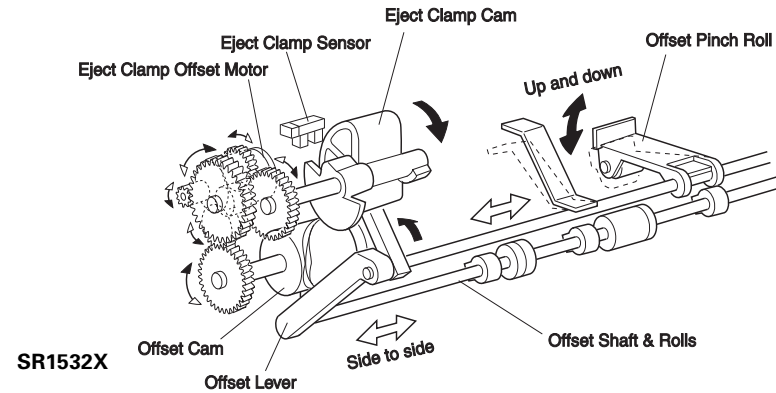

SR1532X

Figure 2-14. Offset Motor Working Part

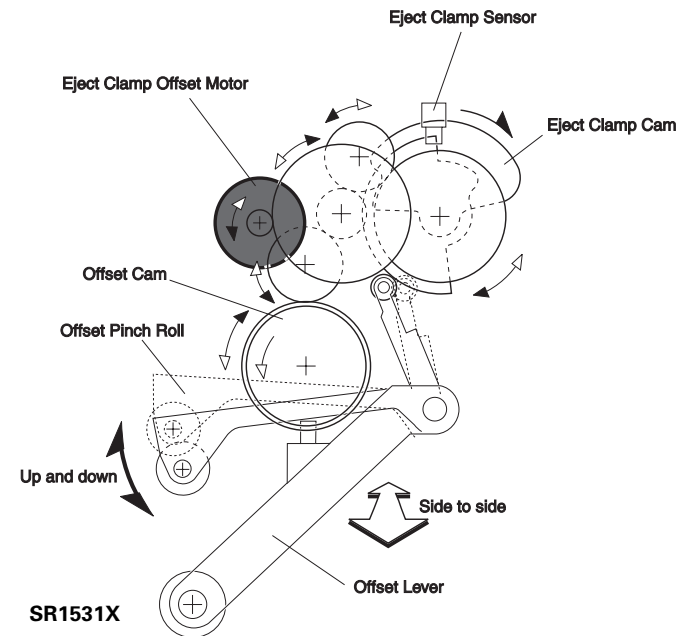

SR1531X

Figure 2-15. Offset motor Operational Outline

### 2.2.7 Stacker Elevator Motor

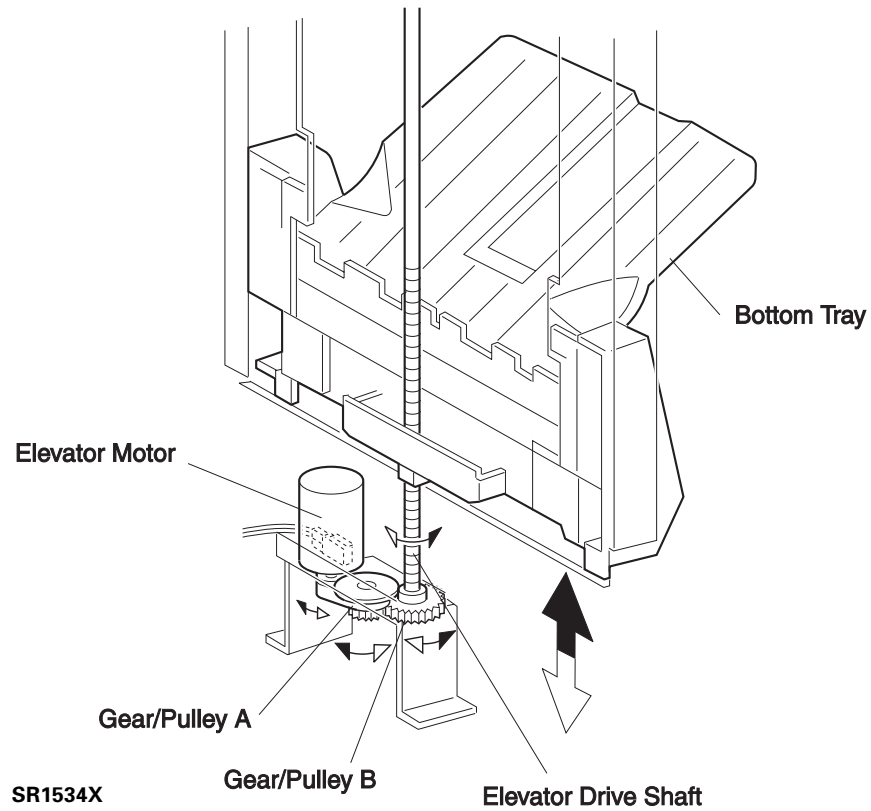

Figure 2-16. Stacker Elevator Motor Working Part

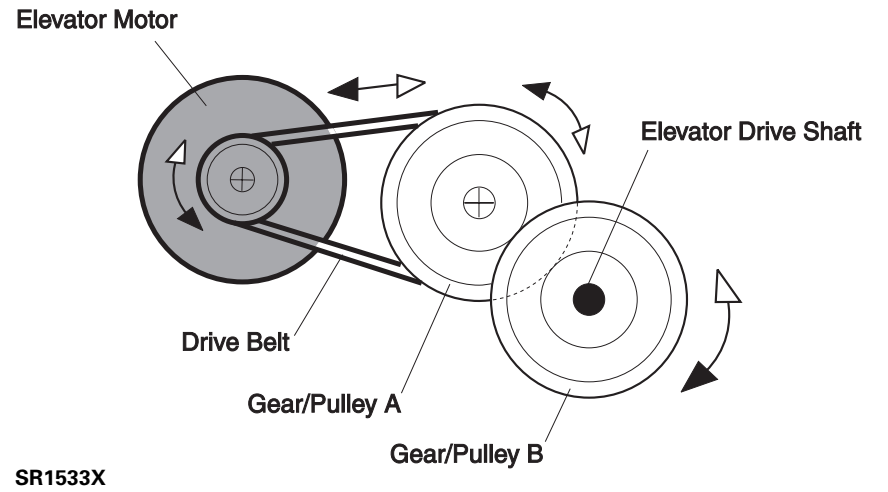

Figure 2-17. Stacker Elevator Motor Operational Outline

### 2.2.8 Tray Motors

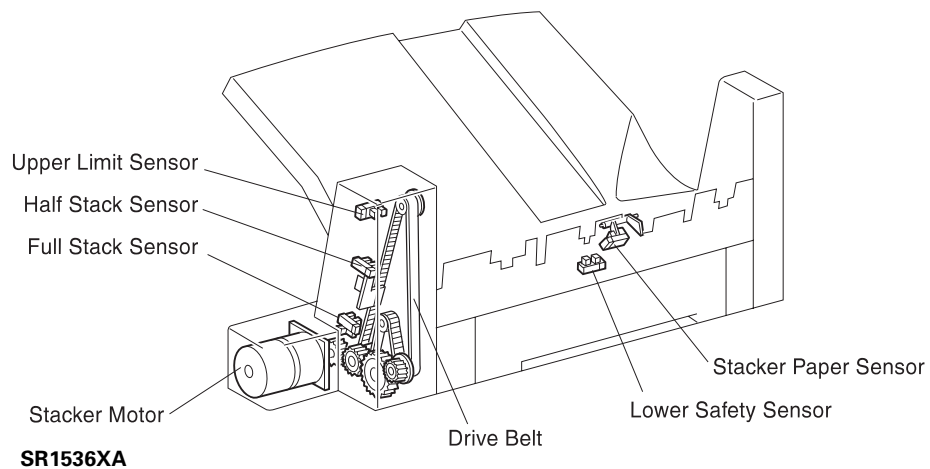

Figure 2-18. Tray Motor Working Part

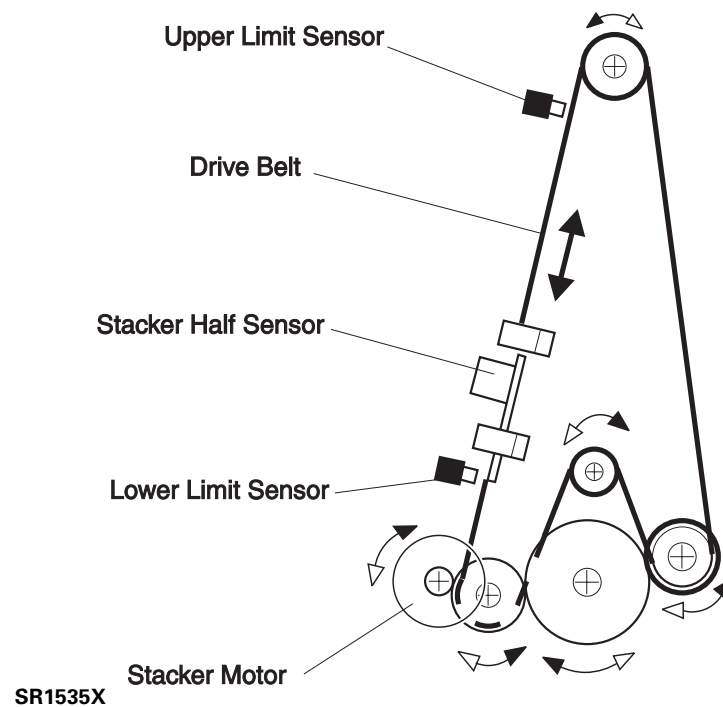
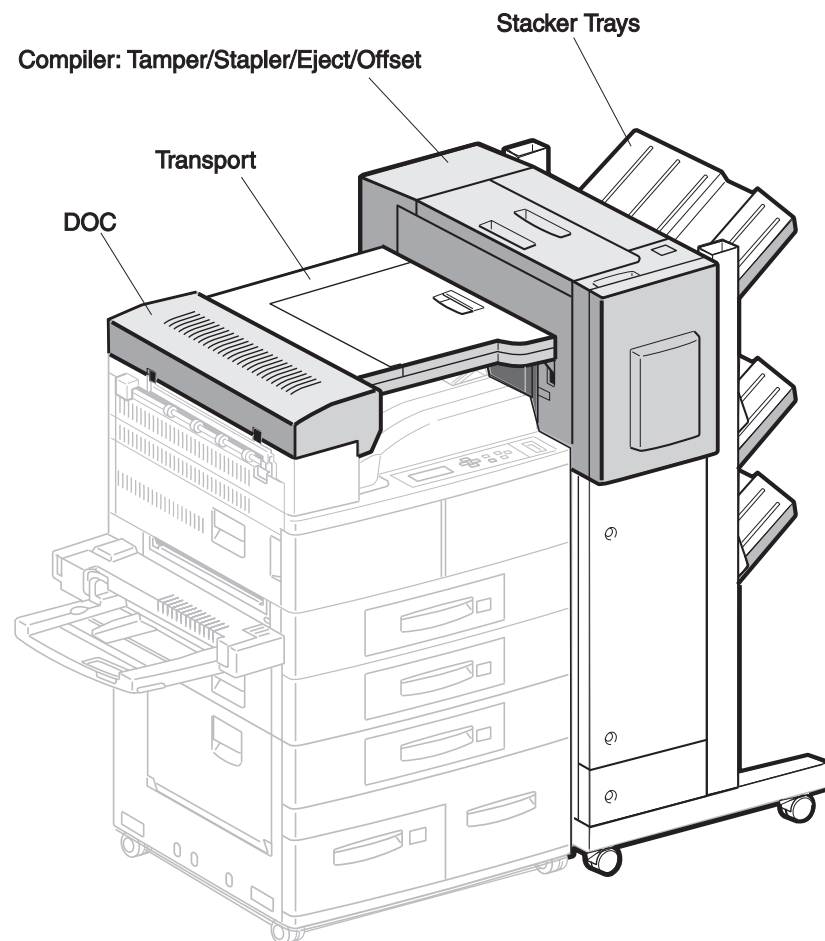

Figure 2-19. Tray Motor Operational Outline



## 2.3 Paper Path

Paper goes through four main components of DOC, Transport, Compiler, and Stacker Tray.



SR1502X

Figure 2-20. Main Components

### 2.3.1 Paper Path on the Unstaple Mode

#### 2.3.1.1 DOC

DOC is at the exit of the Fuser of the printer. DOC includes IN Gate. When Finisher Stapler is selected, the Finisher PWB drives the IN Gate Solenoid to alternate the direction of the IN Gate and carries paper to the HCS Transport Assembly.

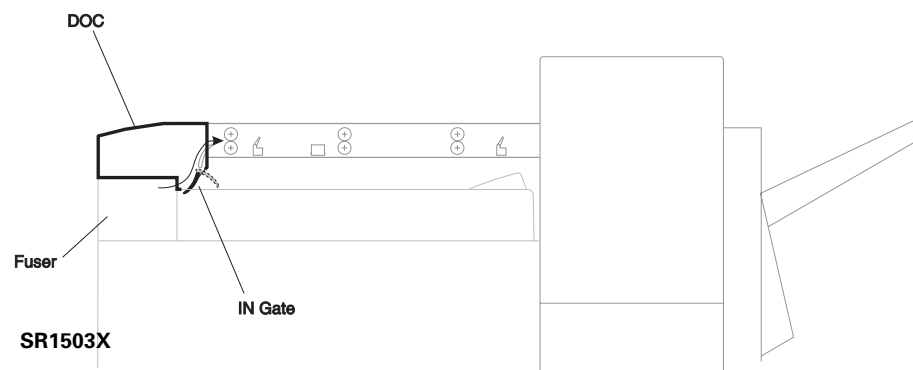

Figure 2-21. DOC

#### DOC PAPER PATH MAIN COMPONENTS

- IN Gate  
On normal mode, IN Gate faces up. When selected to send paper to Staple Stacker, IN Gate Solenoid commands IN Gate to face down.
- Upper Chute  
Carries paper to the Transport Rolls.
- IN Gate Solenoid  
Controlled by Finisher PWB.

### 2.3.1.2 Transport

Three sets of Transport Rolls send paper through Transport Assembly to Compiler. Transport Entrance Sensor and Transport Exit Sensor supervises paper passing.

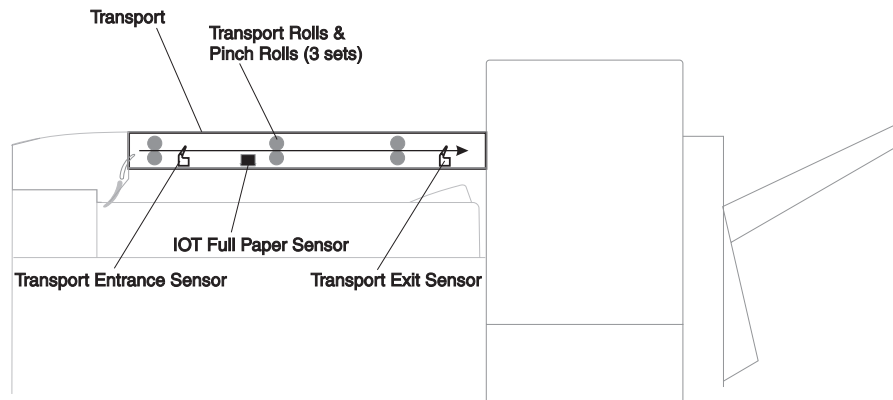

SR1515X

Figure 2-22. Transport

#### TRANSPORT PAPER PATH MAIN COMPONENTS

- Transport Rolls and Pinch Rolls (3 sets)  
Carries paper to the Compiler.
- Transport Entrance Sensor  
Supervises paper entering to the Transport.
- Transport Exit Sensor  
Supervises paper exiting from the Transport.
- IOT Full Paper Sensor  
Supervises the amount of paper on the Face Down Output Tray of the printer. When the Finisher Stapler is installed, IOT Full Paper Sensor supervises on behalf of the printer Full Stack Sensor.

### 2.3.1.3 Exit/Eject

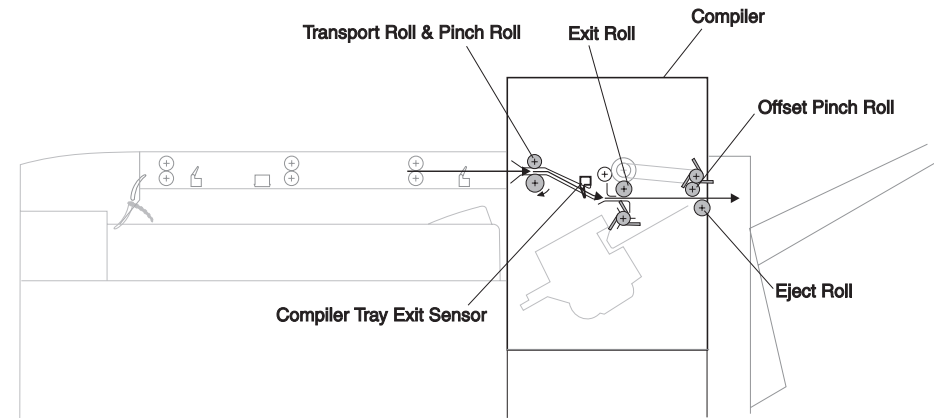

SR1518X

Figure 2-23. Exit / Eject

#### EXIT/EJECT PAPER PATH MAIN COMPONENTS

- Transport Rolls and Pinch Rolls  
Carries paper to the Compiler.
- Compiler Tray Exit Sensor  
Supervises paper passing to the entrance of the Compiler.
- Exit Roll / Paddle Assembly  
Carries paper to the Offset/Eject Rolls.
- Eject Roll / Paddle Assembly  
Ejects paper to the Stacker Tray.
- Offset Pinch Roll  
Offsets and ejects paper to the Stacker Tray.

### 2.3.1.4 Stacker Trays

Eject Toll and Paddle Assembly ejects paper to the Stacker Tray. Stacker Elevator shifts three Trays up and down as one of the Trays faces Eject Rolls. ID Sensor informs the Finisher PWB that the selected Tray is at the right position. Respective sensors supervise the amount of paper on each Tray.

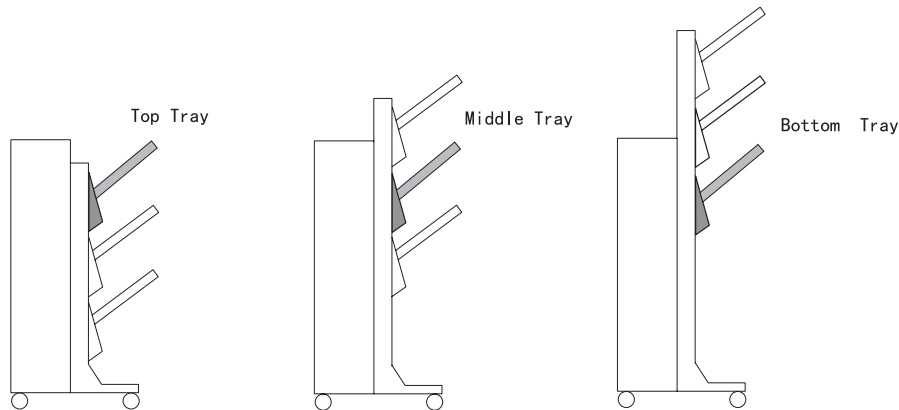

SR1512X

Figure 2-24. Stacker Tray

#### OFFSET PAPER PATH MAIN COMPONENTS

- Top, Middle, Bottom Tray  
Shifted up and down as one unit. Selected Tray stops in front of the Eject Rolls.
- Stacker Motor (Top, Middle, Bottom)  
Shifts each Tray up and down.
- Stacker Paper Sensor (Top, Middle, Bottom)  
Supervises if there are paper on each Tray.
- Stacker Full Sensor (Top, Middle, Bottom)  
Supervises if paper on each Tray is 100% full.
- Stacker Half Full Sensor (Top, Middle, Bottom)  
Supervises if paper on each Tray is 100% full.

### 2.3.2 Paper Path on the Staple Mode

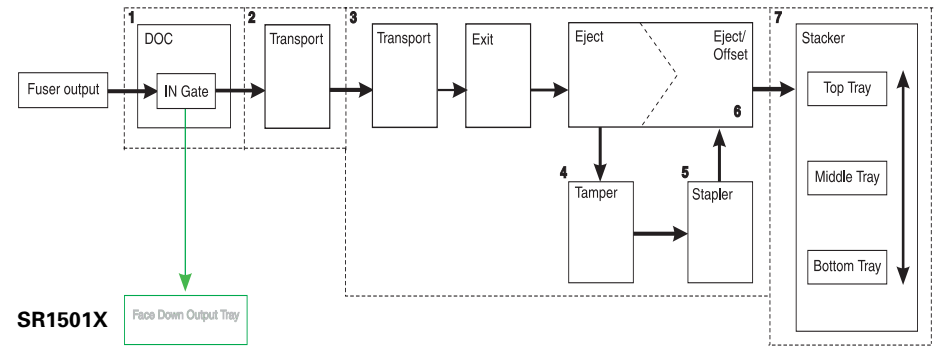

Figure 2-25. Paper Path Outline

#### 2.3.2.1 DOC

Operating principle of DOC on the staple mode is the same as on the unstaple mode. ("DOC" on page 25)

#### 2.3.2.2 Transport

Operating principle of Transport on the staple mode is the same as on the unstaple mode. ("Transport" on page 26)

### 2.3.2.3 Exit/Eject

Paper sent from the Transport is compiled and jogged on the Compiler Tray by specified amount. Paper is bundled by stapler at the specified corner and is ejected to the Stacker.

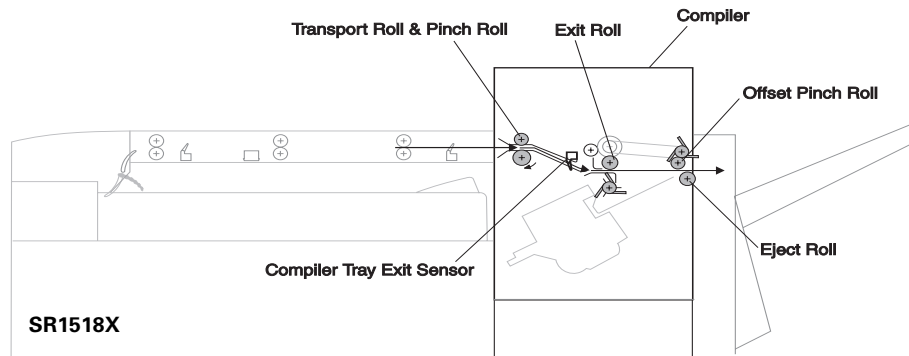

Figure 2-26. Exit/Eject

#### EXIT/EJECT PAPER PATH MAIN COMPONENTS

- Transport Rolls and Pinch Rolls  
Carries paper to the Compiler.
- Compiler Tray Exit Sensor  
Supervises paper entering to the Compiler.
- Exit Roll / Paddle Assembly  
Carries paper to the Offset/Eject Rolls.
- Eject Roll / Paddle Assembly  
Eject Roll counter-revolves and sends paper to the Compiler Tray.

### 2.3.2.4 Compiler/Tamper

Eject Roll counter-revolves and sends paper to the Compiler Tray. When paper is sent to the Compiler Tray, End Wall Motor lifts End Wall.

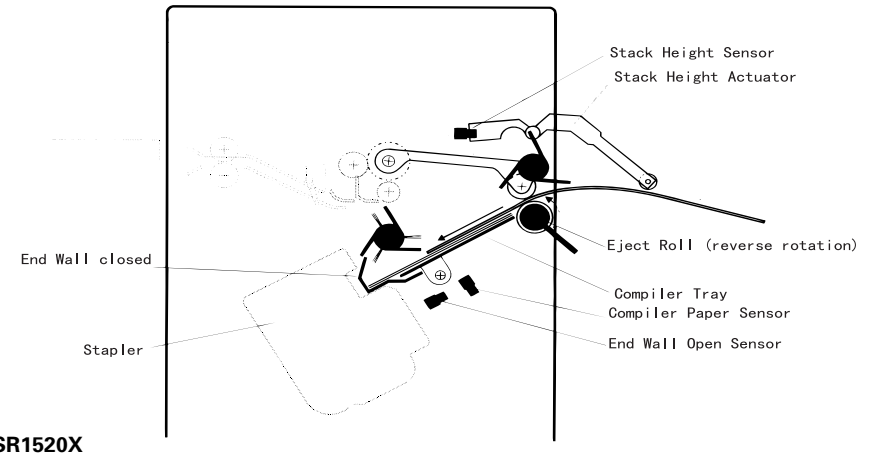

Figure 2-27. Compiler/Tamper

#### COMPILER /TAMPER PAPER PATH MAIN COMPONENTS

- Eject Roll  
Eject Roll counter-revolves and sends paper to the Compiler Tray.
- Compiler Tray  
Paper is compiled and jogged on the Compiler Tray by specified amount.
- End Wall  
Jogs paper. Lowered when stapling.
- End Wall Motor  
Shifts End Wall up and down.
- Tamper  
Tamps paper one by one.
- Compiler Tray Solenoid  
When amount of paper on the Compiler Tray reaches twenty five, Compiler Tray Solenoid shifts Compiler Tray down.

### 2.3.2.5 Stapler

End Wall is shifted down when stapling. Stapler Motor shifts Stapler Unit along the rail. Sensors along rail supervises the position of the Stapler Unit.

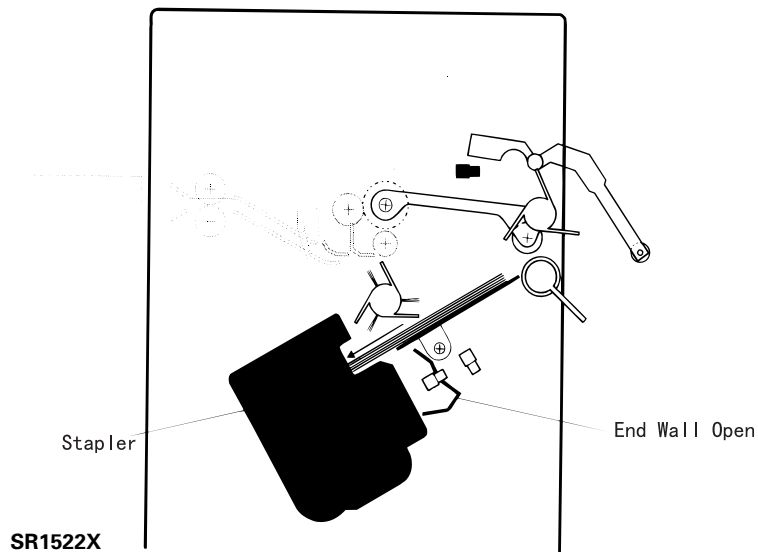

Figure 2-28. Stapler

#### STAPLER PAPER PATH MAIN COMPONENTS

- Stapler Front Corner Sensor  
Detects the front corner position of the Stapler Unit.
- Stapler Front Straight Sensor  
Detects the front straight position of the Stapler Unit.
- Stapler Rear Straight Sensor  
Detects the rear straight position of the Stapler Unit.
- Stapler Assembly  
Includes Stapler Head and Stapler Cartridge.

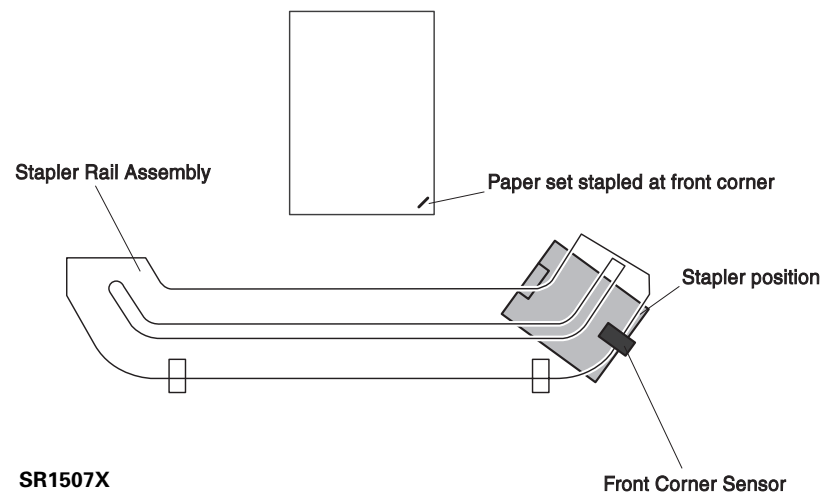

Figure 2-29. Front Corner Staple

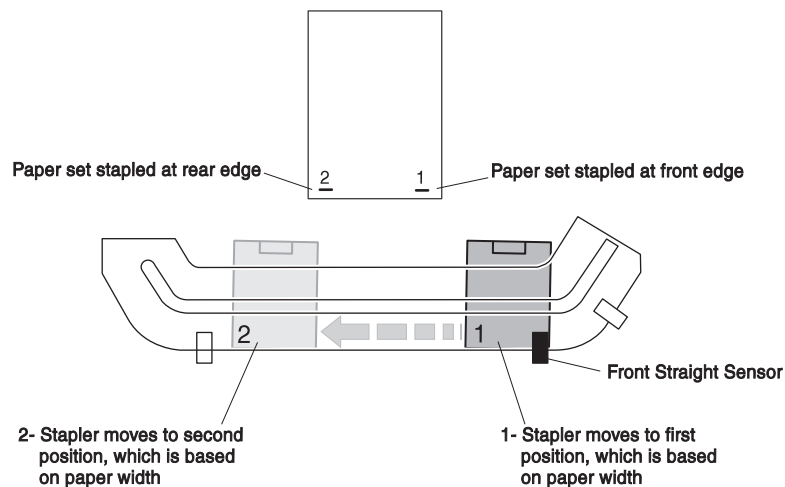

Figure 2-30. Dual (Front and Rear Edge) Staple

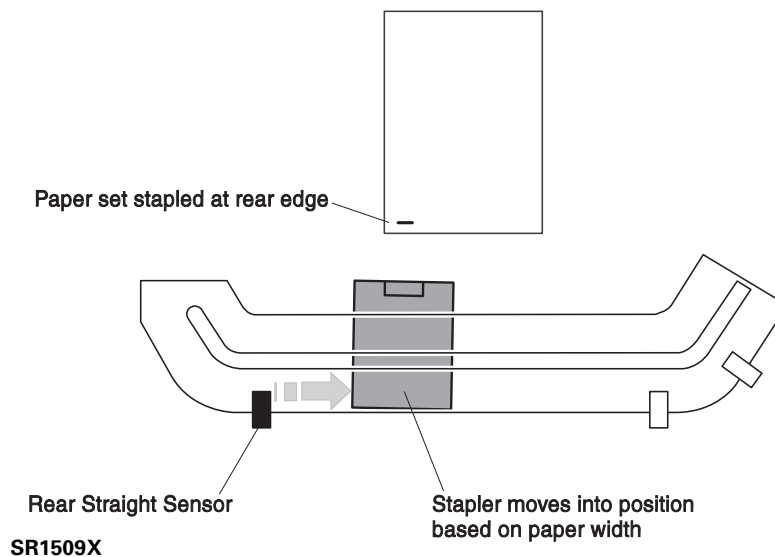

Figure 2-31. Rear Edge Staple

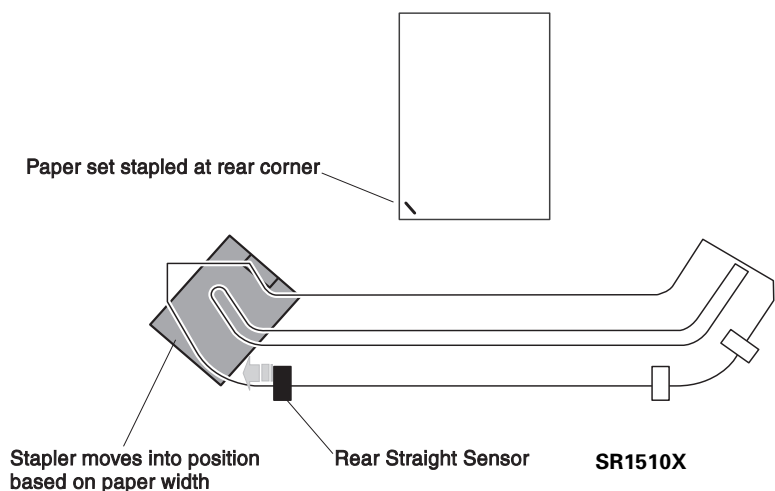

Figure 2-32. Rear Corner Staple

### 2.3.2.6 Eject/Offset

Eject Roll revolves counterclockwise and Eject Roll and Offset Roll eject paper from the Compiler Tray.

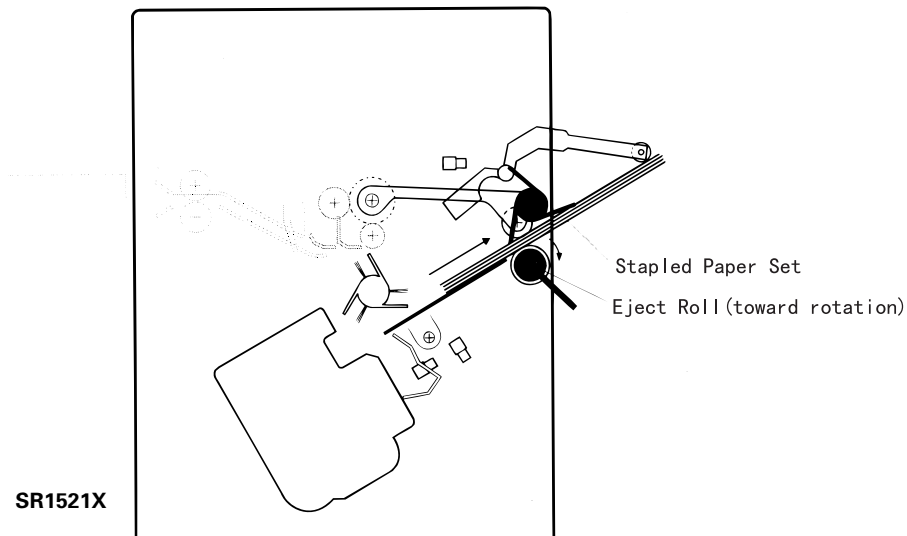
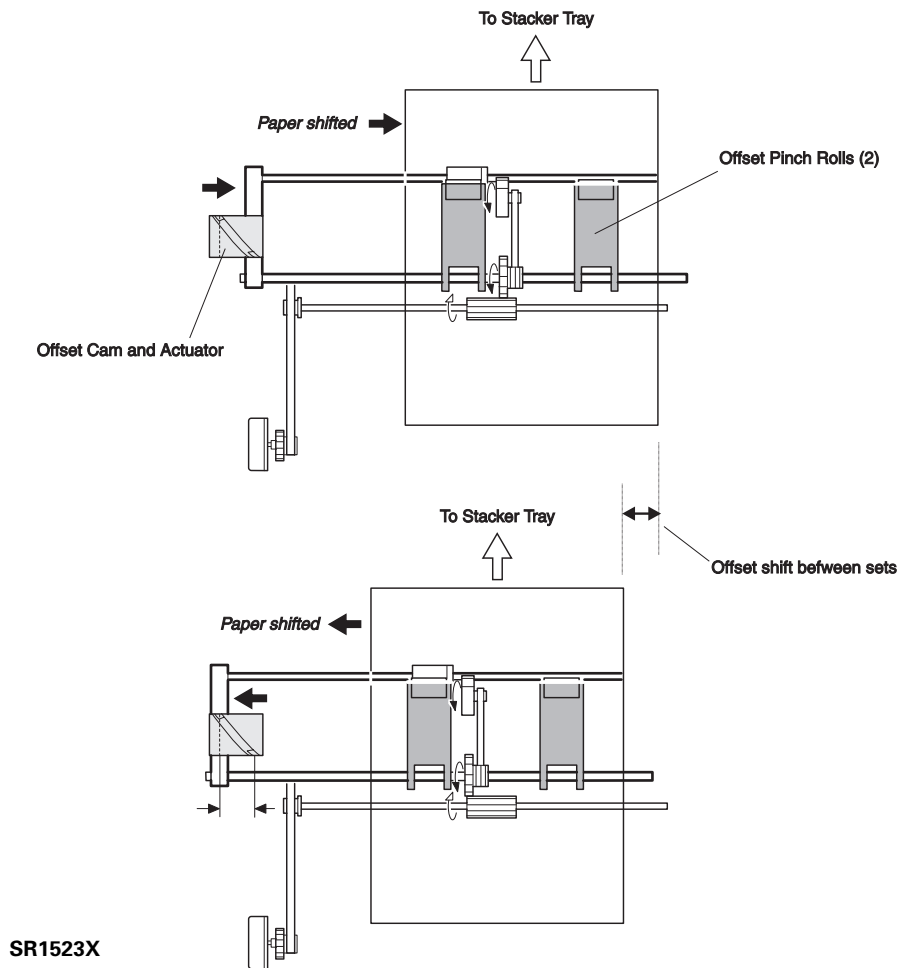

Figure 2-33. Eject/Offset

The following figure is paper ejecting mechanism when offsetting paper.



SR1523X

Figure 2-34. Paper Eject When Offsetting Paper

### 2.3.2.7 Stacker Trays

Operating Principle of Stacker Tray on staple mode is the same as on the unstaple mode. ("Stacker Trays" on page 27)

CHAPTER

3

**DISASSEMBLY AND ASSEMBLY**



## 3.1 Outline

---

This chapter explains main installation and removal procedures of staple cartridge or Finisher Stapler.

### 3.1.1 Preparation

Before starting removal and installation;

1. Turn off the printer.
2. Remove AC power code from the plug.
3. Wear eliminate-static wrist band to avoid damaging any electronic parts on the print circuit board which can be easily damaged by static electricity.

### 3.1.2 Attention for Handling



- Parts name here may not match the name on the parts list precisely. For example, MSI Tray Assembly is the same as Tray Assembly MSI on parts list.
- Use the screw with right type and right size when installing the parts.  
Wrong screws may damage threaded holes.  
Do not inflict any unnecessary force for removing and installing parts.

### 3.1.3 Notation for Removal and Installation

1. The position (R for right) on the removal and installation is noted, provided that an operator faces printer Console Panel.
2. The arrows on the figure indicates the direction to move a component when removing it.
3. Slash on the parts name indicates that several components share the same initial word and have the same function. For example, "Gear In/Feed/Out indicates "Gear In, Gear Feed, Gear Out".

## 3.2 Up and Down of Finisher Stapler

---

Finisher Stapler moves up when outputting to the bin 3. This is due to for paper eject bin to move up.

For the safety measures, the paper eject bin can be lowered.

Finisher Stapler moves up and down under the following condition.

1. When applying the power;
    - When the Finisher Stapler is at bin 2 or bin 3, it moves down to bin 1.
    - Stop button is unavailable.
    - No panel indication during the move.
  2. When ejecting the paper to the staple Stacker;
    - Move to the target bin.
    - The panel indication during the move is the same as at the normal printing operation.
    - When the EPL-N4000/EPL-N4000+ generates an error, Finisher Stapler moves to the target position. If the printer does not start printing again after the Finisher Stapler has moved for about one minute, the Finisher Stapler moves down to bin 2 or bin 1 as same as in the case of 3.
  3. After ejecting paper to the Finisher Stapler;
    - About one minute after paper went out of compile tray, the Finisher Stapler moves down to the bin 2. If there are no paper on bin 2 nor on bin 3, the Finisher Stapler moves down to bin 1.
    - If the paper on bin 2 and bin 3 is removed after the Finisher Stapler moved down to bin 2, the Finisher Stapler moves down to bin 1 after about one minute.
    - No panel indication during the move.
  4. When pressing the stop button of the Finisher Stapler;
    - The Finisher Stapler moves down to bin 1.
    - When the stop button is pressed during the printing procedure, bin moves down after the job finishes or after the certain set of copies has done.
- When the stop button is pressed, the LED of the switch lights on and the panel indicates "warm up".
  - About one minute after the Finisher Stapler moves down to bin 1, or when the stop button is pressed again, the LED of the switch lights off and then printer will be on line again.

### 3.3 Installation and Removal of Finisher Stapler and Stapler Cartridge

#### 3.3.1 Finisher Stapler

##### 3.3.1.1 Installation

1. Install the DOC HCS (High Capacity Stacker).
2. Lock 2 casters in the front of HCF.
3. Install the Docking Rail into the left side of the printer's bottom.
4. Install the Docking Rail into the right side of the printer's bottom.
5. Install the Bracket Assembly EMI.
6. Raise the Transport Assembly horizontally and raise the Shaft-Transport and support the Transport Assembly.
7. Move the Finisher Stapler close to the right side of the printer.
8. Connect HCS AC power cord to the right side of the printer.
9. Push the Finisher Stapler toward to the printer, making sure that a positioning pin goes into the positioning hole of DOC HCS.



■ Be careful not to shut in AC power cable between the staple Stacker and the printer.

10. Fix the Docking Rail with a screw.
11. Connect the HCS interface cable to the back side of the printer.

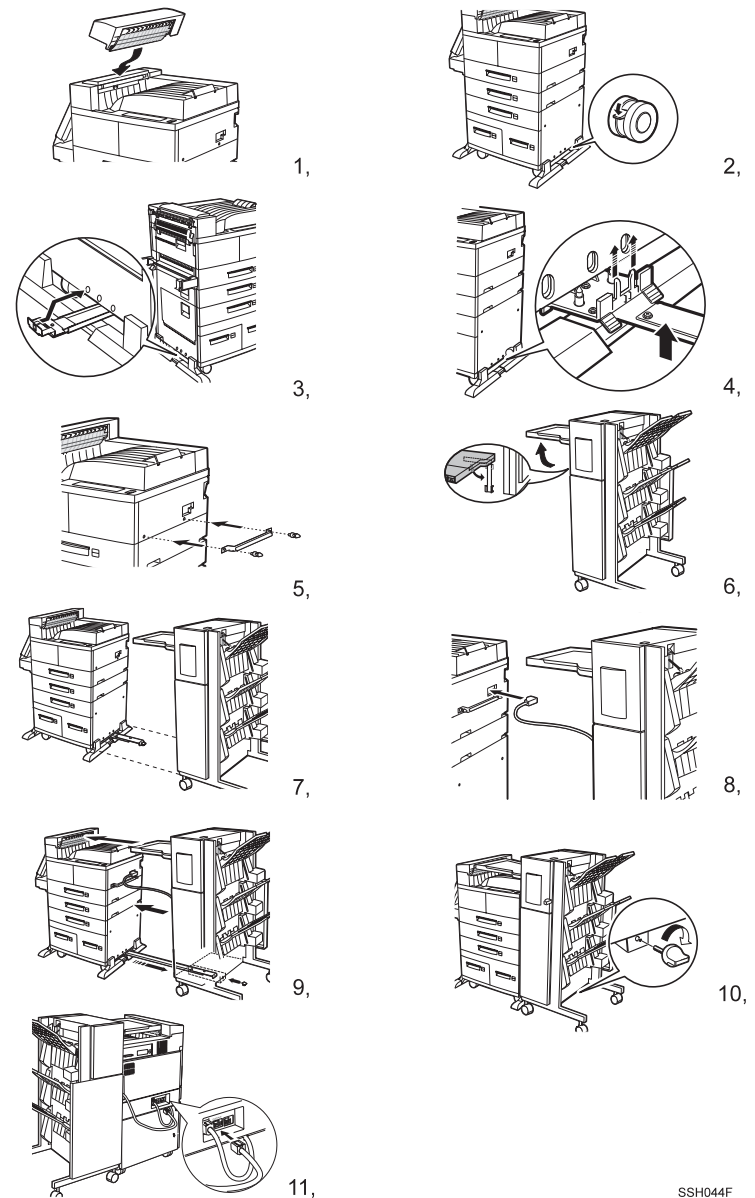
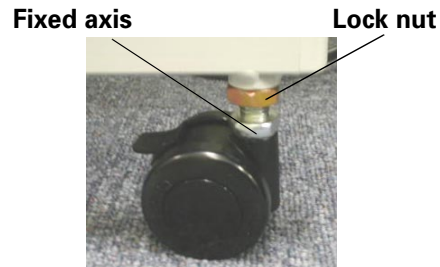

Figure 3-1. Installing the Finisher Stapler

SSH044F



After installing the Finisher Stapler, adjust the height of the caster (two). The adjustment procedure is as follows.



**Table 3-1. Height Adjustment**

1. Loosen the lock nut.
2. Adjust the height by moving up and down the Finisher Stapler with revolving the caster fixed axis.

**NOTE:** *Be careful not to leave any gap between Finisher Stapler and the printer body.*

3. After adjustment, fix the lock nut.

### 3.3.2 Removal

1. Disconnect the HCS interface cable from the printer.
2. Remove a screw from the edge of the Docking Rail.
3. Slide the Finisher Stapler away from the printer.
4. Disconnect HCS AC power cable from the printer.
5. Put the Shaft-Transport back and face down the Transport Assembly.
6. Remove Bracket Assembly EMI.
7. Remove the Docking Rail from the right side of the printer's bottom.
8. Remove the Docking Rail from the left side of the printer's bottom.
9. Remove DOC HCS.

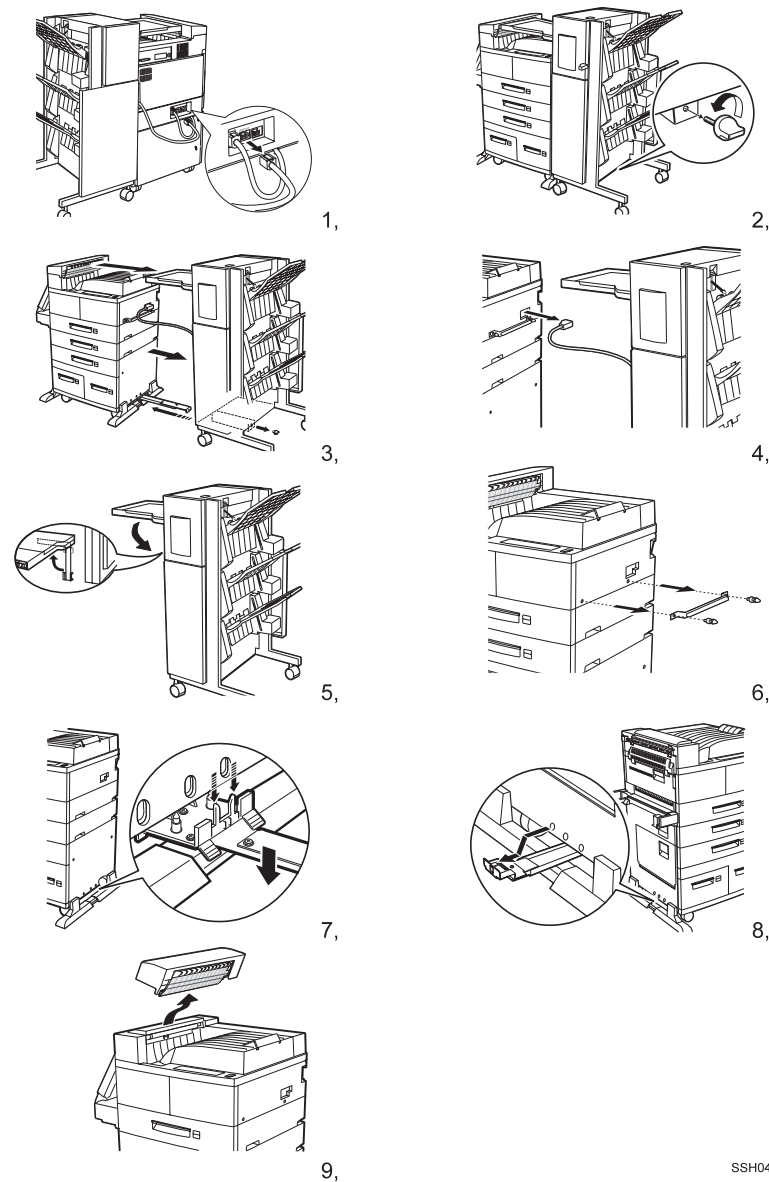

SSH045F

Figure 3-2. Removing the Finisher Stapler

### 3.3.3 Installing and Replacing Stapler Cartridge

1. Put staple into the cartridge.
2. Pull the sticker straight out to the arrow direction in the figure 2.
3. Open the Front Cover Assembly and set the cartridge with staple inside.
4. Close the Front Cover Assembly.

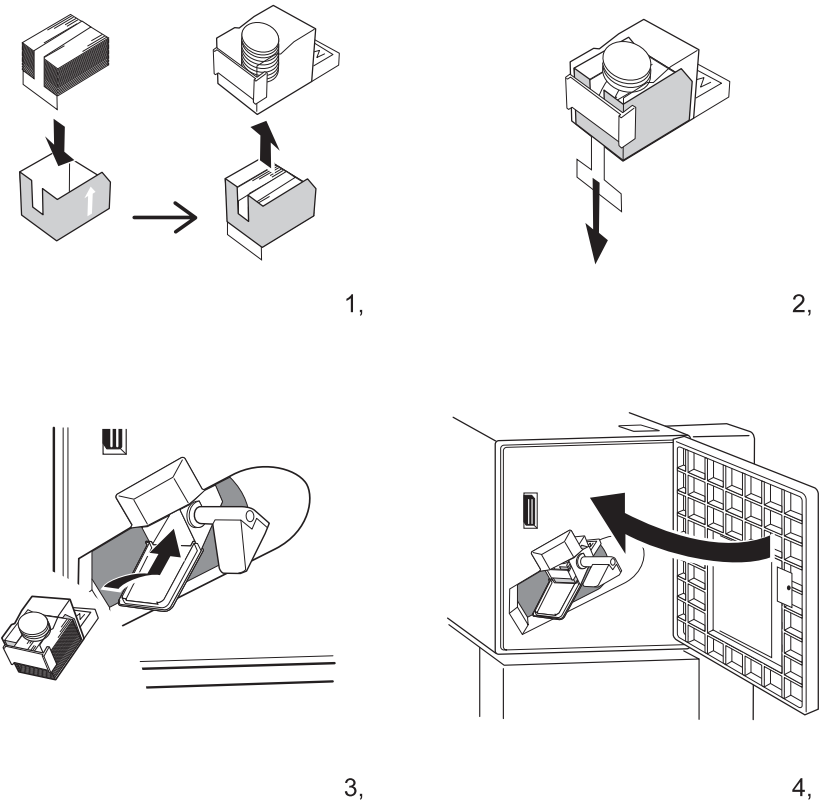

SSH046FA

Figure 3-3. Installing the Staple Cartridge

### 3.3.4 Replacing the Stapler Cartridge

1. Open the Front Cover Assembly.
2. Turn the lever and take out the cartridge.
3. Take out the cartridge and remove the empty staple case.
4. Put the staple to the case.
5. Pull out the sticker straight to the arrow direction in the figure 5.
6. Open the Front Cover Assembly and set the cartridge with staple inside.
7. Close the Front Cover Assembly.

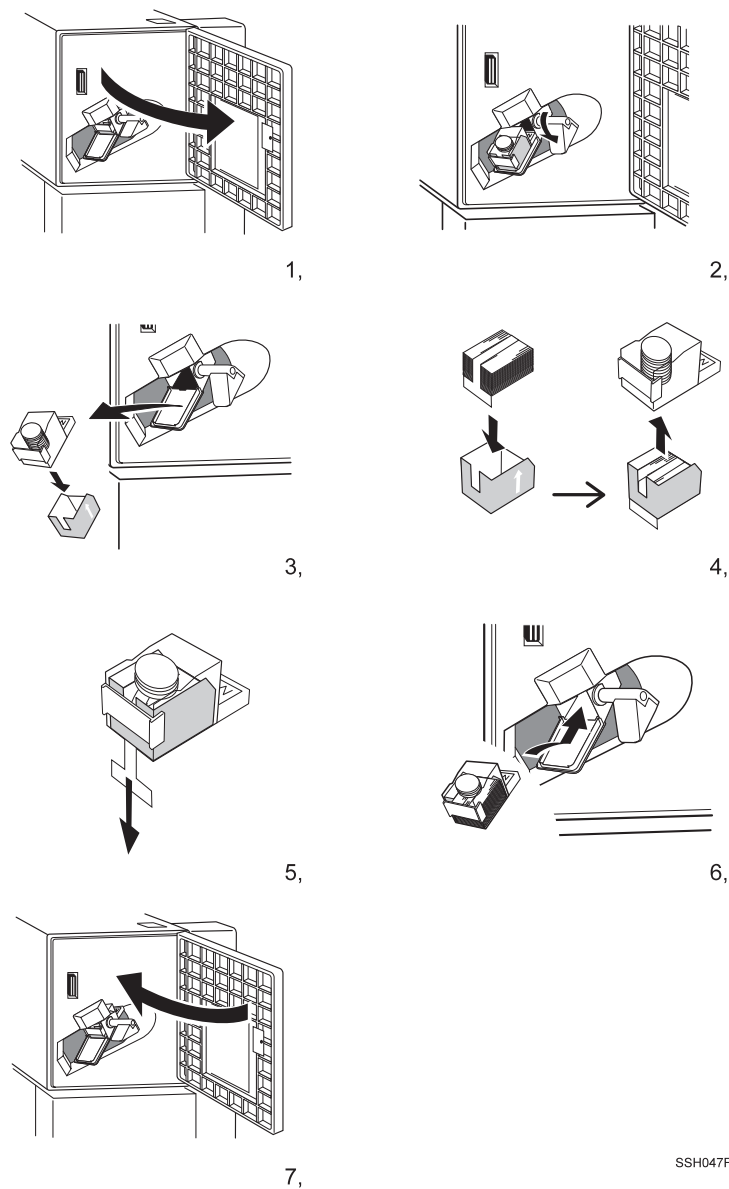

Figure 3-4. Exchanging the Staple Cartridge

SSH047F

## 3.4 Disassembly and Assembly

### 3.4.1 Front Cover Assembly

Refer to the exploded diagram (Figure 4-25, "HCS Covers Front" on page 166).

#### 3.4.1.1 Removal

1. Open the Front Cover Assembly.
2. Remove E ring from the upper hinges where Front Cover Assembly and Front Cover Inner Assembly are connected on.
3. Lift Front Cover Assembly off.

#### 3.4.1.2 Installation

1. Install Front Cover Assembly, inserting two pairs of hinges of Front Cover Inner Assembly into holes of Front Cover Assembly.
2. Put E ring around the upper hinges and secure Front Cover Assembly on Front Cover Inner Assembly.
3. Close Front Cover.

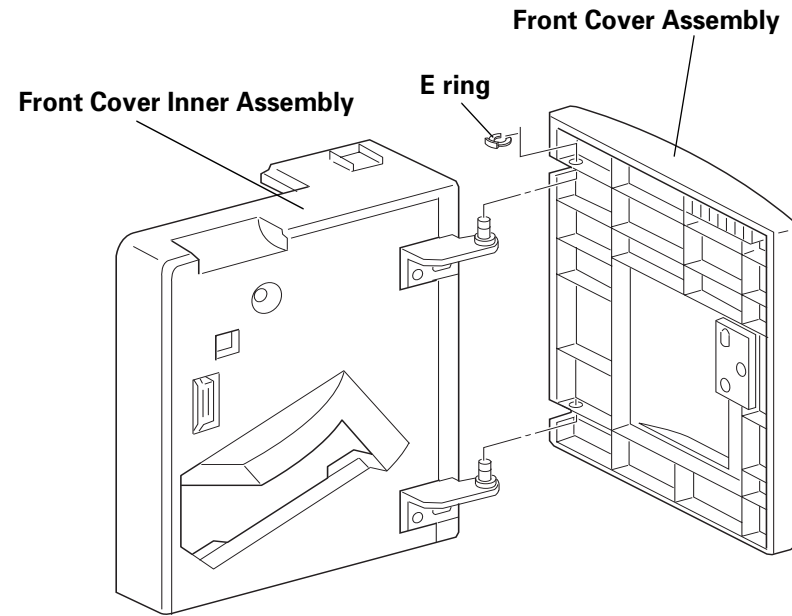

SER744FA

Figure 3-5. Front Cover Assembly



### 3.4.2 Front Cover Inner Assembly

Refer to the exploded diagram (Figure 4-25, "HCS Covers Front" on page 166).

#### 3.4.2.1 Removal

1. Open Top Cover.
2. Open Front Cover Assembly.
3. Remove the screw securing Front Cover Inner Assembly to HCS frame.
4. Securing Unload While Run button pressed, lift Front Cover Inner Assembly and remove it from HCS frame.
5. Remove Front Cover Assembly. (Refer to "Front Cover Assembly" on page 40)

#### 3.4.2.2 Installation

1. Install Front Cover Assembly. (Refer to "Front Cover Assembly" on page 40)
2. Install Front Cover Inner Assembly to the body by inserting two tabs at the bottom of Front Cover Inner Assembly into cutouts in HCS frame.
3. Securing Unload While Run button pressed, insert the top part of Front Cover Inner Assembly to HCS frame.
4. Set Front Cover Inner Assembly as Unload While Run button can move smoothly when pressed and unpressed.
5. Secure Front Cover Inner Assembly to HCS frame with a screw.
6. Close the Front Cover Assembly.
7. Close Top Cover.

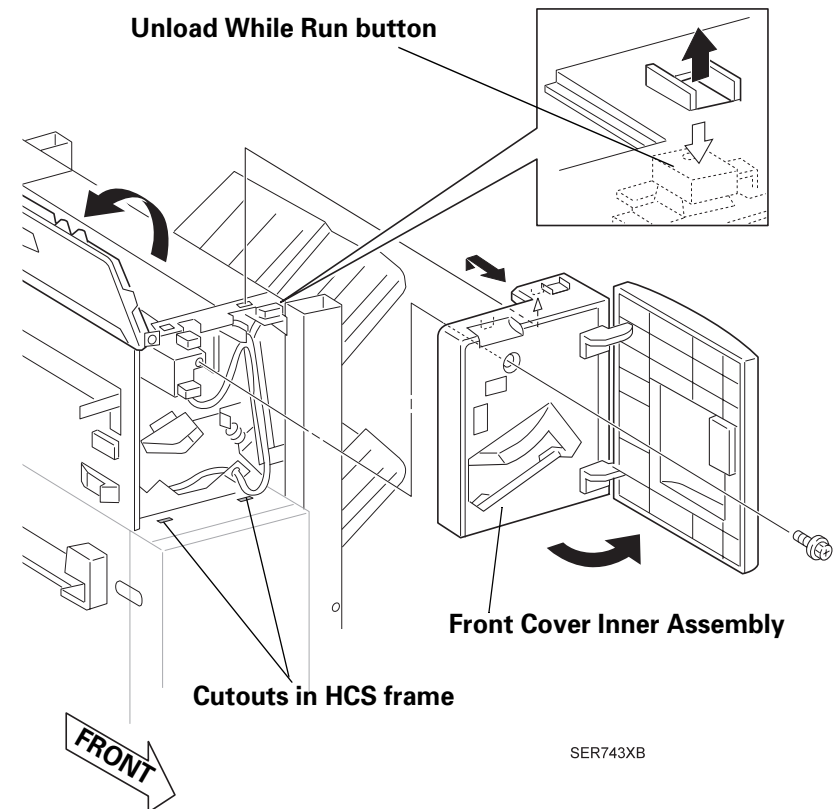

Figure 3-6. Front Cover Inner Assembly

### 3.4.3 Front Low Cover

Refer to the exploded diagram (Figure 4-25, "HCS Covers Front" on page 166).

#### 3.4.3.1 Removal

1. Remove HCS from the printer. (Refer to "Finisher Stapler" on page 35)
2. Remove three screws securing Front Low Cover to HCS frame.
3. Pull Front Low Cover to the right and remove it from the frame.

#### 3.4.3.2 Installation

1. Place Front Low Cover as shown in the Figure 3-7.
2. Parallel Front Low Cover to the frame as three tabs on the frame fall into rectangular cutouts on Front Low Cover.
3. Insert Front Low Cover to HCS frame.
4. Secure Front Low Cover to HCS frame with three screws.
5. Connect HCS and the printer. (Refer to "Finisher Stapler" on page 35)

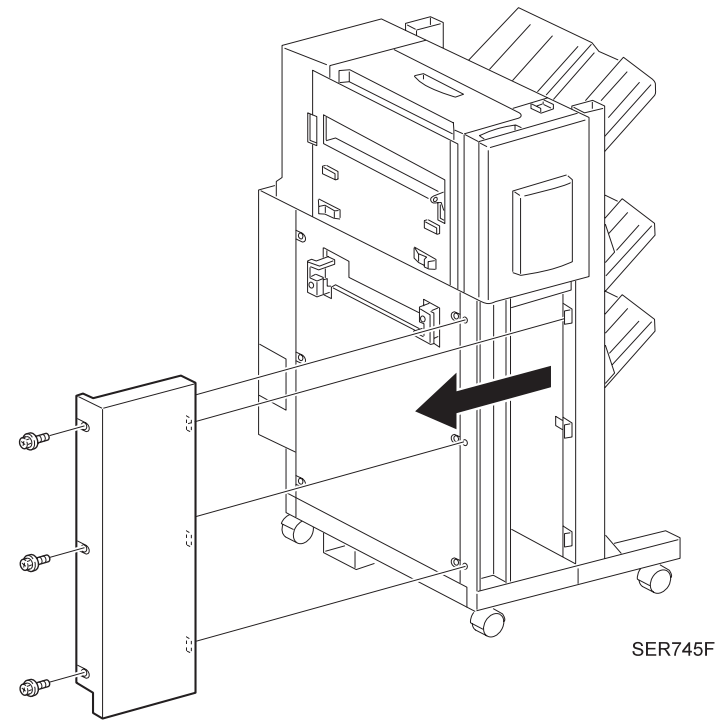

Figure 3-7. Front Low Cover

### 3.4.4 L/H Cover

Refer to the exploded diagram (Figure 4-25, "HCS Covers Front" on page 166).

#### 3.4.4.1 Removal

1. Remove Transport Assembly. (Refer to "Transport Assembly" on page 130)
2. Remove Rear Cover (Refer to "Rear Cover" on page 46)
3. Remove three screws securing L/H Cover to HCS frame.
4. Remove L/H Cover.

#### 3.4.4.2 Installation

1. Install L/H Cover by first sliding L/H Cover front end into the Front Cover.
2. Place L/H Cover to the frame as threaded holes of the frame and those of L/H Cover be at the same position.
3. Secure L/H Cover to HCS frame with three screws.
4. Install Rear Cover. (Refer to "Rear Cover" on page 46)
5. Install Transport Assembly. (Refer to "Transport Assembly" on page 130)

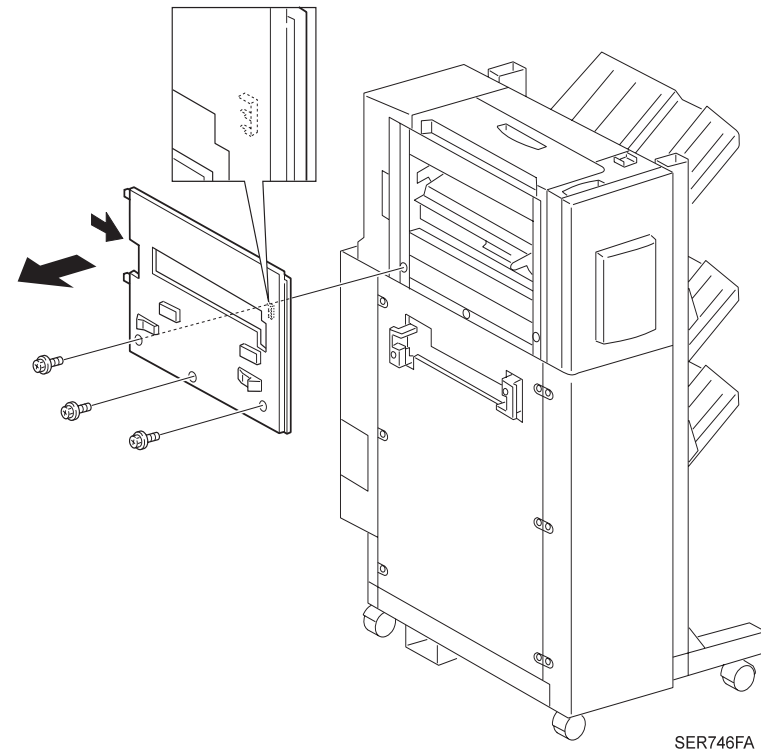

Figure 3-8. L/H Cover

### 3.4.5 L/H Cover Low

Refer to the exploded diagram (Figure 4-25, "HCS Covers Front" on page 166).

#### 3.4.5.1 Removal

1. Remove HCS from the printer. (Refer to "Finisher Stapler" on page 35)
2. Remove Transport Assembly (Refer to "Transport Assembly" on page 130)
3. Remove six screws securing L/H Cover Low to HCS frame.
4. Remove L/H Cover Low from the frame.

#### 3.4.5.2 Installation

1. Place L/H Cover Low to HCS frame.
2. Secure L/H Cover Low to the HCS frame with six screws.
3. Install Transport Assembly. (Refer to "Transport Assembly" on page 130)
4. Connect HCS and the printer. (Refer to "Finisher Stapler" on page 35)

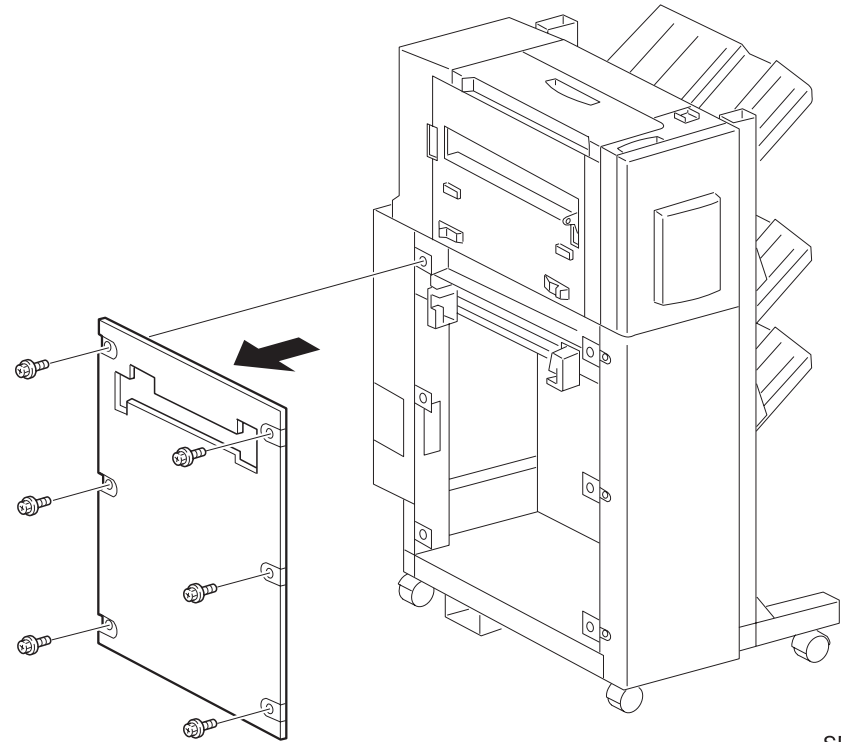

SER739F

Figure 3-9. L/H Cover Low

### 3.4.6 Eject Cover

Refer to the exploded diagram (Figure 4-26, "HCS Covers Rear" on page 167).

#### 3.4.6.1 Removal

1. Remove Rear Cover. (Refer to "Rear Cover" on page 46)
2. Remove Front Cover Inner Assembly (Refer to "Front Cover Inner Assembly" on page 41)
3. Open Top Cover.
4. Remove four screws securing Eject Cover to HCS frame.
5. Remove Eject Cover from the frame.

#### 3.4.6.2 Installation

1. Place Eject Cover as shown in the Figure 3-10 and put Cover into HCS frame.
2. Place Cover as four threaded holes of Cover and those of HCS frame fall into the same position.
3. Secure Eject Cover to HCS frame with four screws.
4. Install Front Cover Inner Assembly. (Refer to "Front Cover Inner Assembly" on page 41)
5. Install Rear Cover. (Refer to "Rear Cover" on page 46)

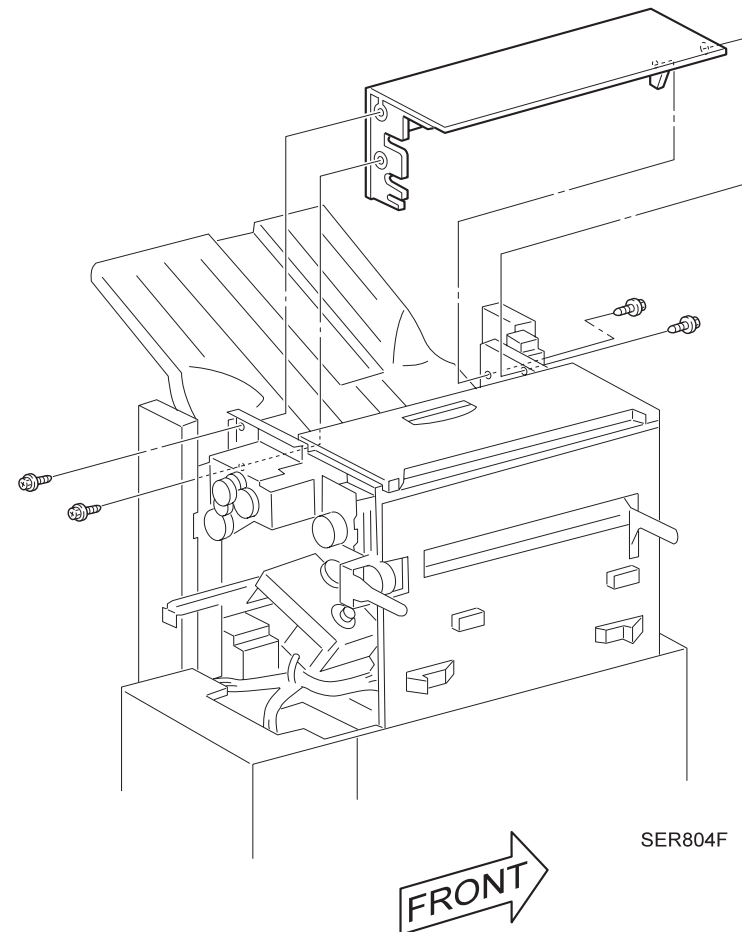

Figure 3-10. Eject Cover

### 3.4.7 Rear Cover

Refer to the exploded diagram (Figure 4-26, "HCS Covers Rear" on page 167).

#### 3.4.7.1 Removal

1. Open the Top Cover.
2. Remove two screws securing Rear Cover to HCS frame.
3. Lift Cover and remove it from the frame.

#### 3.4.7.2 Installation

1. Open the Top Cover.
2. Install the Cover by hanging two tabs under the top face on two cutouts of HCS frame.
3. Secure Rear Cover to HCS frame with two screws.

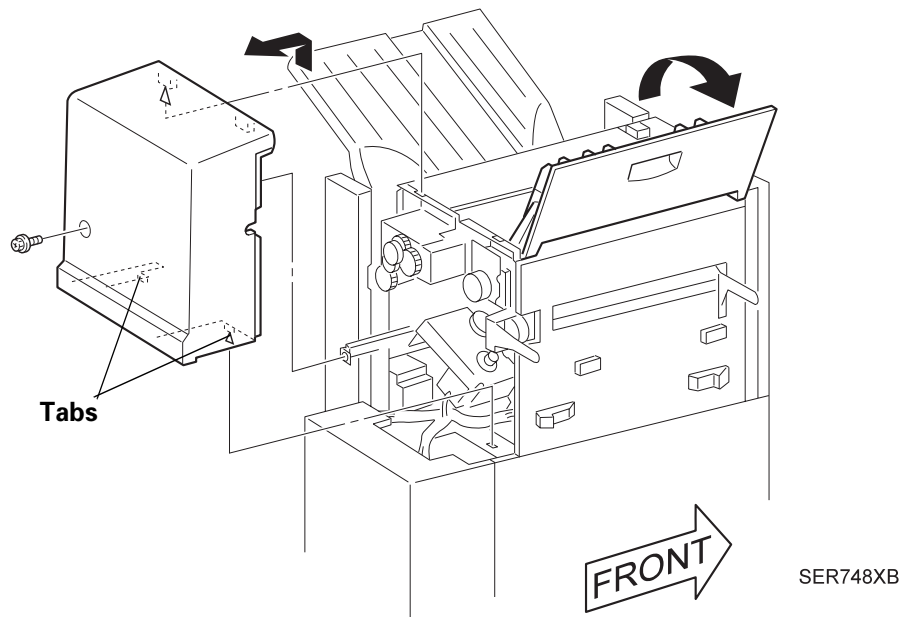

Figure 3-11. Rear Cover

### 3.4.8 Harness Cover

Refer to the exploded diagram (Figure 4-26, "HCS Covers Rear" on page 167).

#### 3.4.8.1 Removal

1. Remove three screws securing the Harness Cover to HCS frame.
2. Remove the cover.

#### 3.4.8.2 Installation

1. Install Harness Cover as shown in the
2. Secure Harness Cover to HCS frame with three screws.

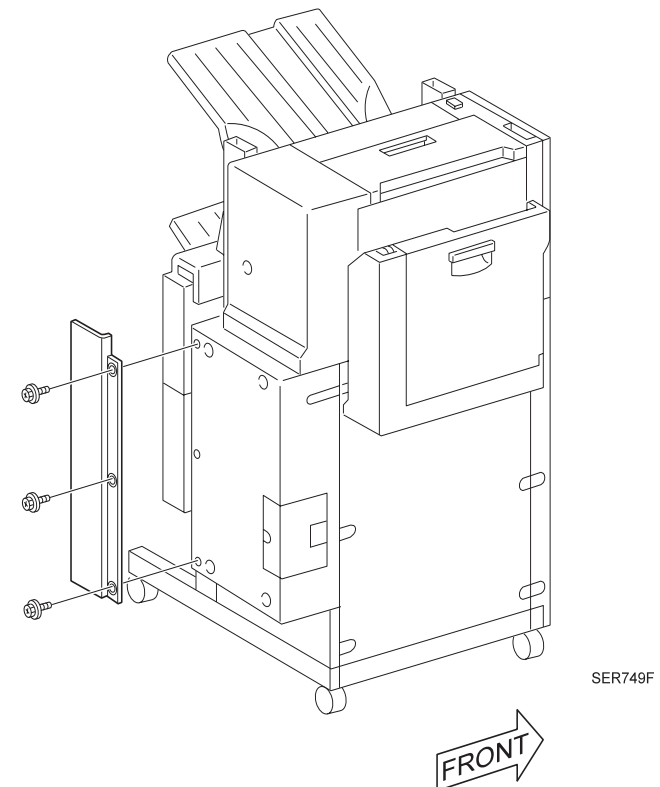

Figure 3-12. Harness Cover

### 3.4.9 Add Cover

Refer to the exploded diagram (Figure 4-26, "HCS Covers Rear" on page 167).

#### 3.4.9.1 Removal

1. Remove one screw securing the Add Cover to the HCS frame.
2. Remove the Add Cover.

#### 3.4.9.2 Installation

1. Place the Add Cover as shown in the Figure 3-13.
2. Slide the Add Cover parallel to the frame as tabs of the HCS frame come onto the rectangular cutouts of the Add Cover.
3. Secure the Cover to HCS frame with one screw.

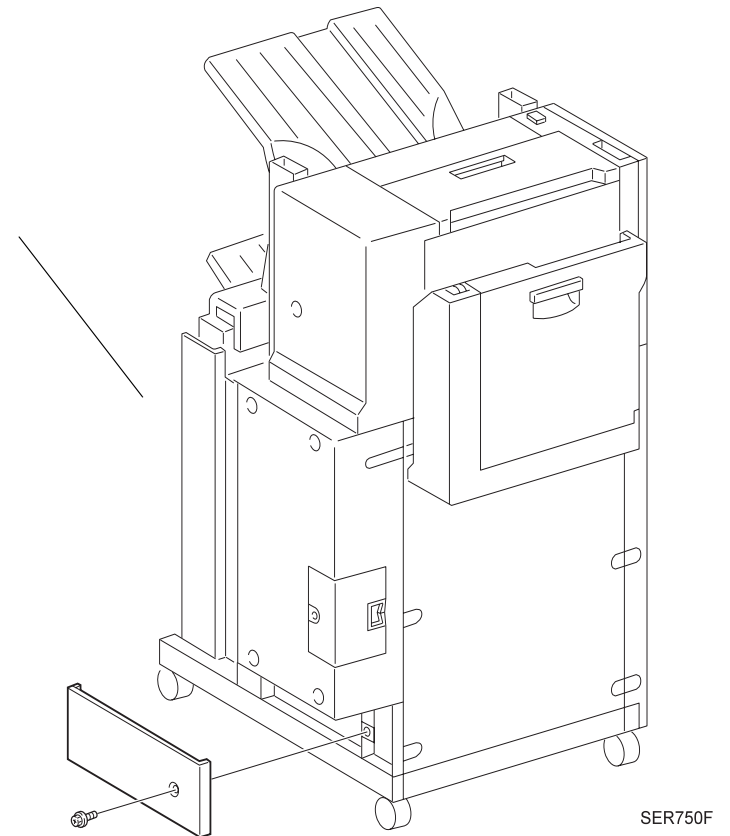

Figure 3-13. Add Cover

### 3.4.10 Finisher Stapler PWB Cover and Connector Cover

Refer to the exploded diagram (Figure 4-26, "HCS Covers Rear" on page 167).

#### 3.4.10.1 Removal

1. Remove the screw securing the Connector Cover and remove it.

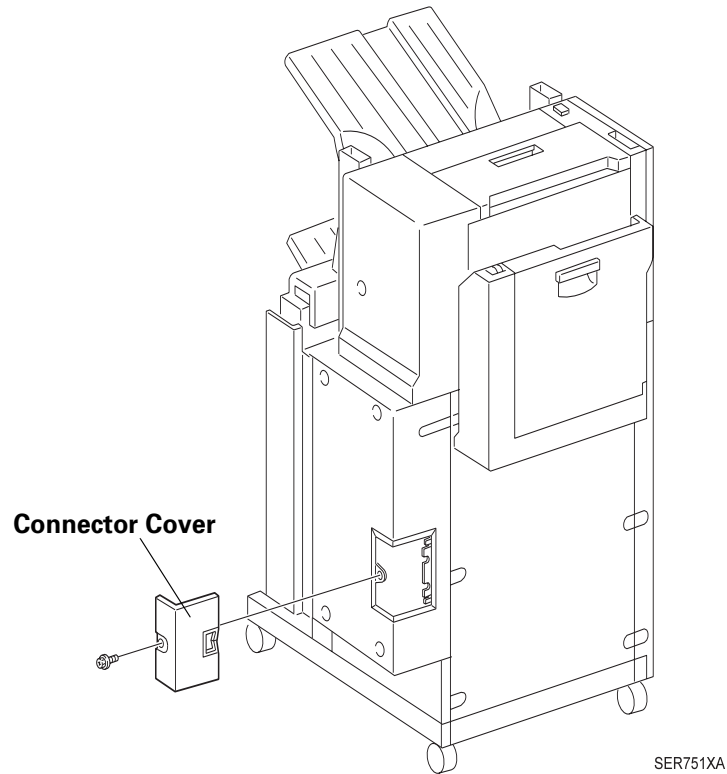

Figure 3-14. Connector Cover

2. Remove Harness Cover. (Refer to "Harness Cover" on page 46)
3. Remove four screws securing PWB Cover Assembly to HCS frame and pull out the PWB Cover from the frame.
4. Remove the wire harness from the Top Harness Clamp. (see Figure 3-15)

5. Remove the wire harness from the Bottom Harness Clamp.
6. Remove Finisher Stapler PWB Cover.

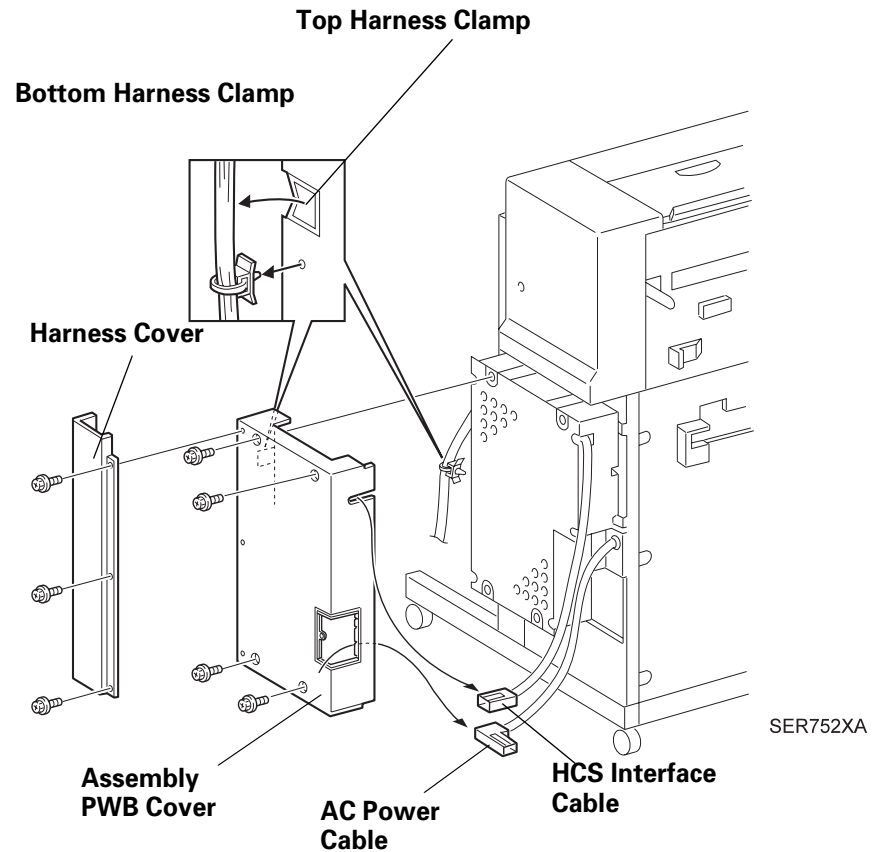

Figure 3-15. Finisher Stapler PWB Cover

#### 3.4.10.2 Installation

1. Install Finisher Stapler PWB to HCS frame. (see Figure 3-15)
2. Let HCS Interface cable through the upper cutout of the Cover.
3. Let AC Power cable through the lower cutout of the Cover.



4. Fix the wire harness by Top Harness Clamp and Bottom Harness Clamp.
5. Install Finisher Stapler PWB Cover to the HCS frame.
6. Secure Finisher Stapler PWB Cover to the HCS frame with four screws.
7. Install Harness Cover. (Refer to "Harness Cover" on page 46)
8. Install Harness Cover to the frame by sliding as tabs on HCS frame comes onto the rectangular cutouts of Connector Cover.



**Ensure AC Power Cable goes through the rectangular cutout of Connector Cover.**

9. Secure Harness Cover to the HCS frame with one screw.

### 3.4.11 Stacker Upper Limit Switch

Refer to the exploded diagram (Figure 4-27, "RACK" on page 168).

#### 3.4.11.1 Removal

1. Remove HCS from the printer. (Refer to "Finisher Stapler" on page 35)
2. Remove L/H Cover. (Refer to "L/H Cover" on page 43)
3. Remove four screws securing Tie Plate (Refer to Figure 4-36, "Exit" on page 183) to the HCS frame.

**NOTE:** Removal of Tie Plate makes it easier to remove Upper Limit Switch.

4. Remove two screws securing Upper Limit Switch Cover and remove the cover.
5. Pull out J273 from Upper Limit Switch.
6. Remove two screws securing Upper Limit Switch to the HCS frame and remove the switch.

#### 3.4.11.2 Installation

1. Place the Stacker Upper Limit Switch as shown in the Figure 3-16 and install the switch to the HCS frame.
2. Secure the switch to the HCS frame with two screws.
3. Connect J273 to the switch.
4. Install the Switch Cover and secure it to the HCS frame with two screws.
5. Install the Tie Plate to the HCS frame as the flat side of the Tie Plate faces out.
6. Secure Tie Plate to the HCS frame with four screws.
7. Install L/H Cover. (Refer to "L/H Cover" on page 43)
8. Connect HCS to the printer. (Refer to "Finisher Stapler" on page 35)

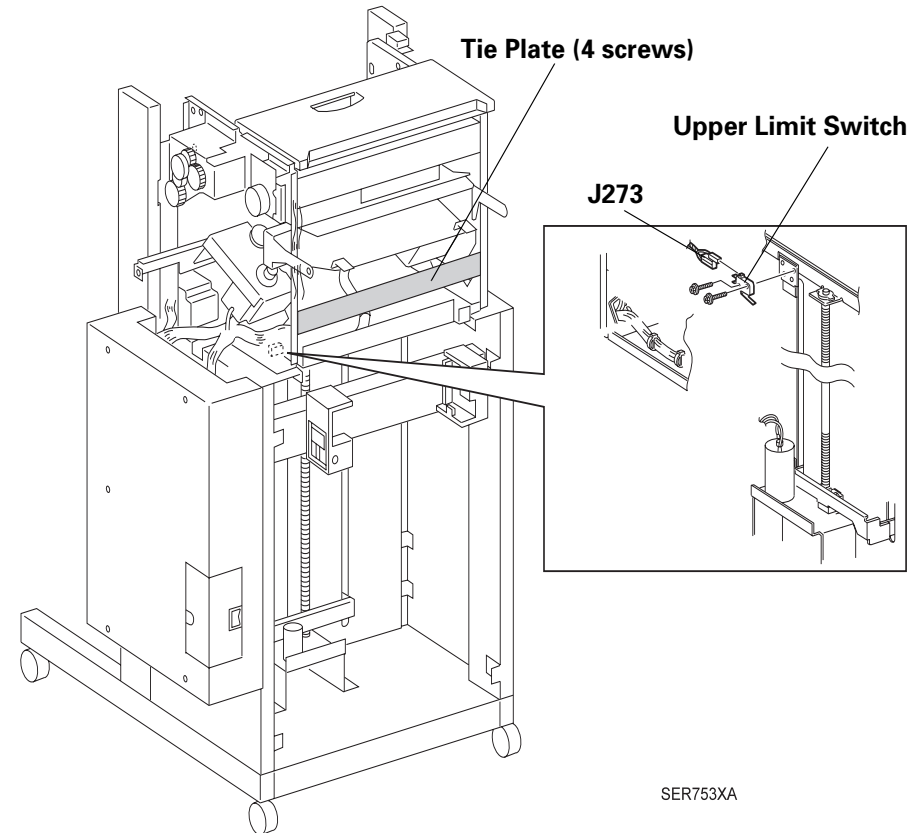

Figure 3-16. Stacker Upper Limit Switch

### 3.4.12 Stacker Lower Limit Switch

Refer to the exploded diagram (Figure 4-27, "RACK" on page 168).

#### 3.4.12.1 Removal

1. Remove HCS from the printer. (Refer to "Finisher Stapler" on page 35)
2. Remove L/H Cover Low. (Refer to "L/H Cover Low" on page 44)
3. Pull out J274 from Lower Limit Switch.
4. Remove two screws securing Lower Limit Switch to the HCS frame and remove the switch.

#### 3.4.12.2 Installation

1. Place the Stacker Lower Limit Switch as shown in the Figure 3-17 and install the switch to the HCS frame.
2. Secure the switch to the HCS frame with two screws.
3. Connect J274 to the switch.
4. Install L/H Cover Low. (Refer to "L/H Cover Low" on page 44)
5. Connect HCS to the printer. (Refer to "Finisher Stapler" on page 35)

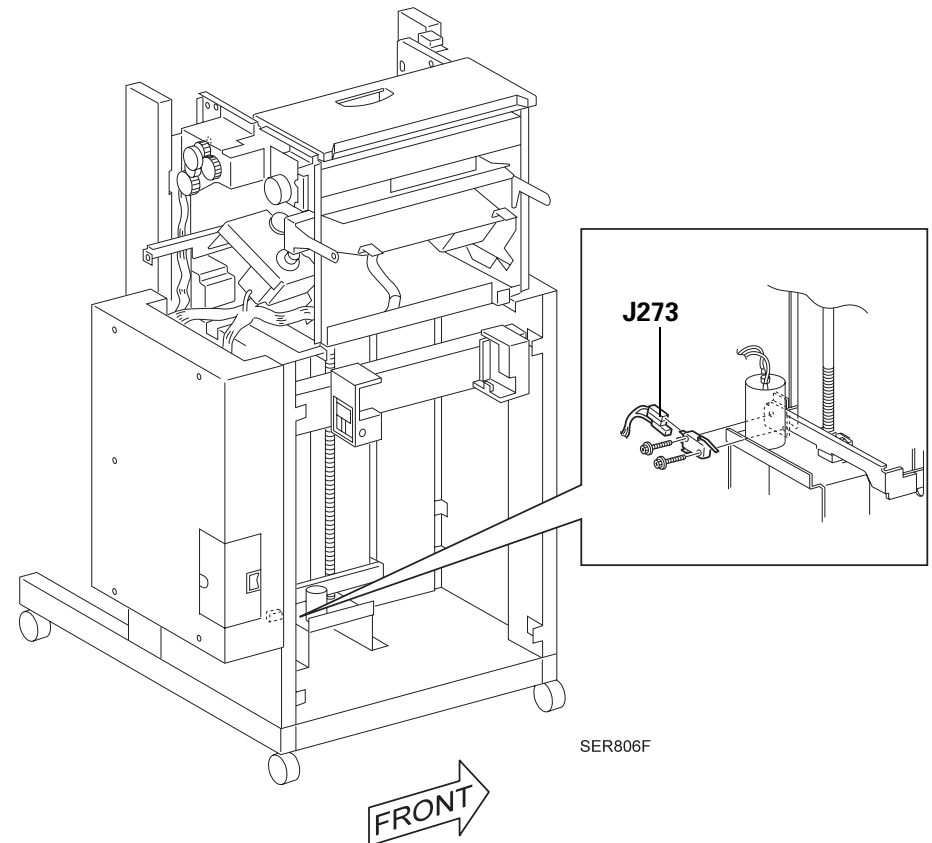

Figure 3-17. Stacker Lower Limit Switch

### 3.4.13 Finisher Stapler Interlock Sensor and Actuator

Refer to the exploded diagram (Figure 4-27, "RACK" on page 168).

#### 3.4.13.1 Removal

1. Remove HCS from the printer. (Refer to "Finisher Stapler" on page 35)
2. Remove L/H Cover Low. (Refer to "L/H Cover Low" on page 44)
3. Release the latches, connecting Finisher Stapler Interlock Sensor to the Docking Support, and remove the Interlock Sensor.
4. Pull out J855M from the Interlock Sensor.
5. Use the flat part of the screwdriver and remove the Actuator from the Actuator Support.

#### 3.4.13.2 Installation

1. Place the Actuator as shown in the Figure 3-18.
2. Insert the inside actuator pivot to the hole of the Docking Support.
3. Insert outside pivot to the arm of Actuator Support.
4. Connect J855M to the Interlock Sensor.
5. Set aside the Actuator while installing the Sensor so that the Actuator would not obstruct installing.
6. Place the Interlock Sensor as shown in the Figure 3-18 and push the rear latches of the Sensor into the four holes of the Docking Support.
7. Swing the Actuator and ensure it moves freely around the detecting part of the Interlock Sensor.
8. Install L/H Cover Low. (Refer to "L/H Cover Low" on page 44)
9. Connect HCS to the printer. (Refer to "Finisher Stapler" on page 35)

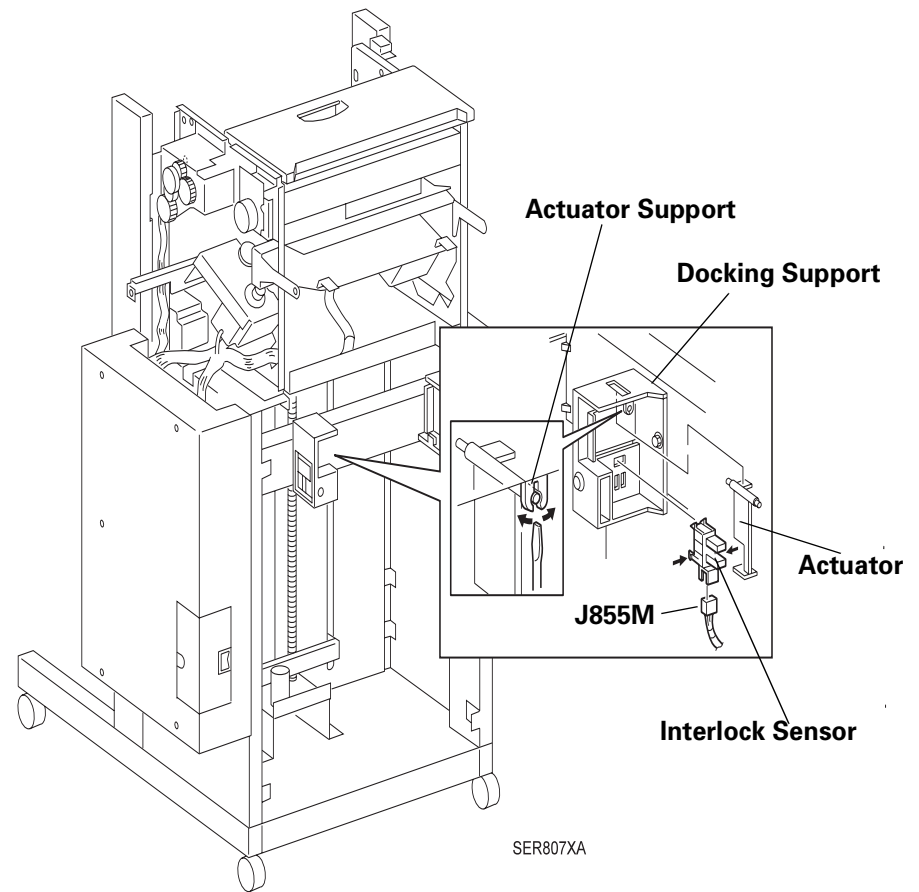

Figure 3-18. Finisher Stapler Interlock Sensor and Actuator

### 3.4.14 Stacker Tray ID Sensor

Refer to the exploded diagram (Figure 4-27, "RACK" on page 168).

#### 3.4.14.1 Removal

1. Remove HCS from the printer. (Refer to "Finisher Stapler" on page 35)
2. Remove Rear Cover. (Refer to "Rear Cover" on page 46)
3. Remove ID Sensor wire harness from the Harness clip.
4. Remove one screw securing Stacker Tray ID Sensor Bracket to the HCS frame and remove the Bracket and the Sensor.
5. Pull out J837 from the Sensor.
6. Release the latches, connecting Sensor to the Bracket, and remove the Sensor.

#### 3.4.14.2 Installation

1. Place the Stacker Tray ID Sensor as shown in the Figure 3-19 and install the Sensor to the Bracket.
2. Connect J837 to the Sensor.
3. Ensure the position-marking tab on the frame goes into the hole of the Bracket and install the Sensor Bracket to the frame.
4. Secure Bracket and Sensor to the HCS frame with one screw.
5. Let ID Sensor wire harness through harness clip.
6. Install Rear Cover. (Refer to "Rear Cover" on page 46)
7. Connect HCS to the printer. (Refer to "Finisher Stapler" on page 35)

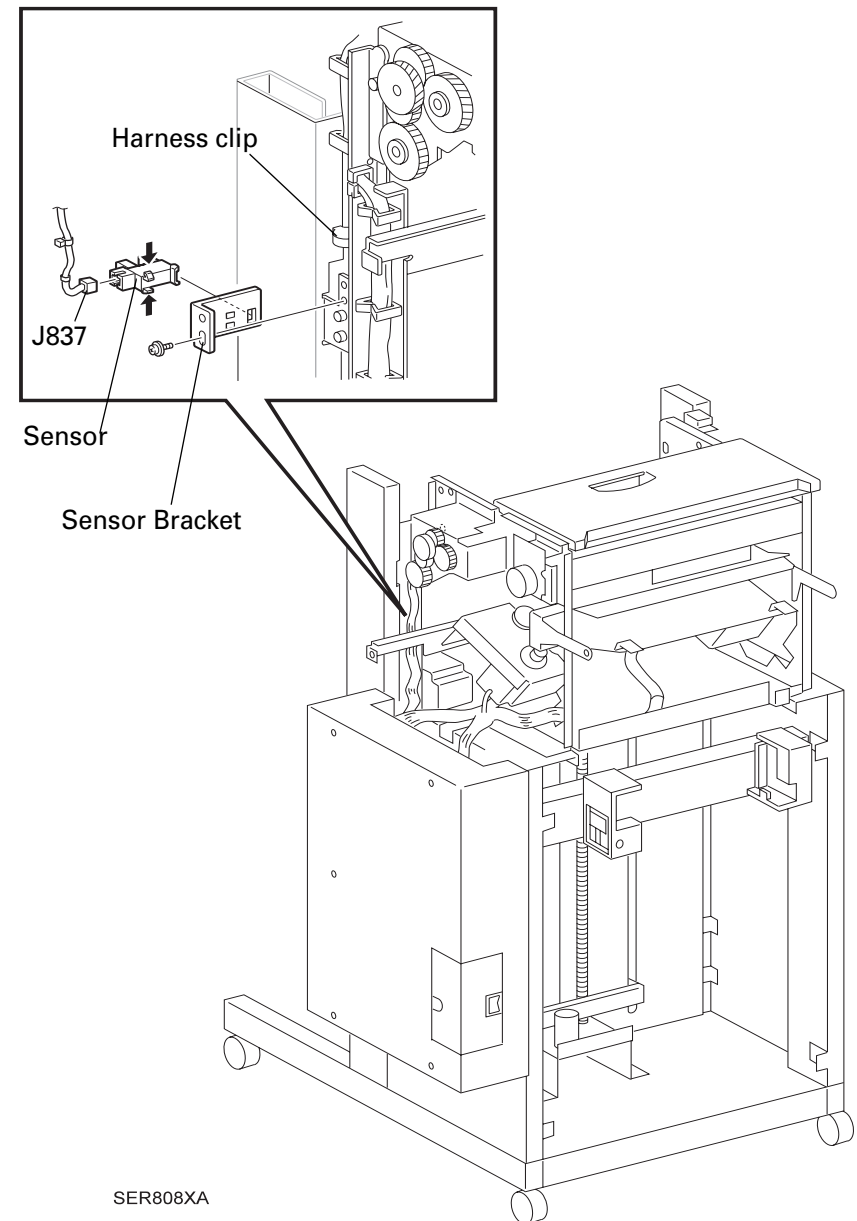

Figure 3-19. Stacker Tray ID Sensor

### 3.4.15 R/H Rack Cover Assembly

Refer to the exploded diagram (Figure 4-27, "RACK" on page 168).

#### 3.4.15.1 Removal

1. Remove Bottom Tray Assembly. (Refer to "Bottom (Lower) Tray Assembly" on page 57)
2. Remove Middle Tray Assembly. (Refer to "Middle Tray Assembly" on page 67)
3. Remove Top Tray Assembly. (Refer to "Top Tray Assembly" on page 77)
4. Remove L/H Cover Low. (Refer to "L/H Cover Low" on page 44)
5. Remove four screws securing Elevator Hinge Bracket to Elevator Hinge Bracket and remove Drive Bracket.
6. Remove four screws securing Elevator Hinge Bracket to R/H Rail Cover and remove Hinge Bracket.
7. Remove six screws securing the Rail to the two grooves on the HCS frame, lift the Rail, and remove it from the HCS frame.
8. Remove seven screws securing R/H Rack Cover to the HCS frame and pull out the Cover from the HCS frame.
9. Pull out J273 from the Upper Limit Switch.
10. Pull out J274 from the Lower Limit Switch.

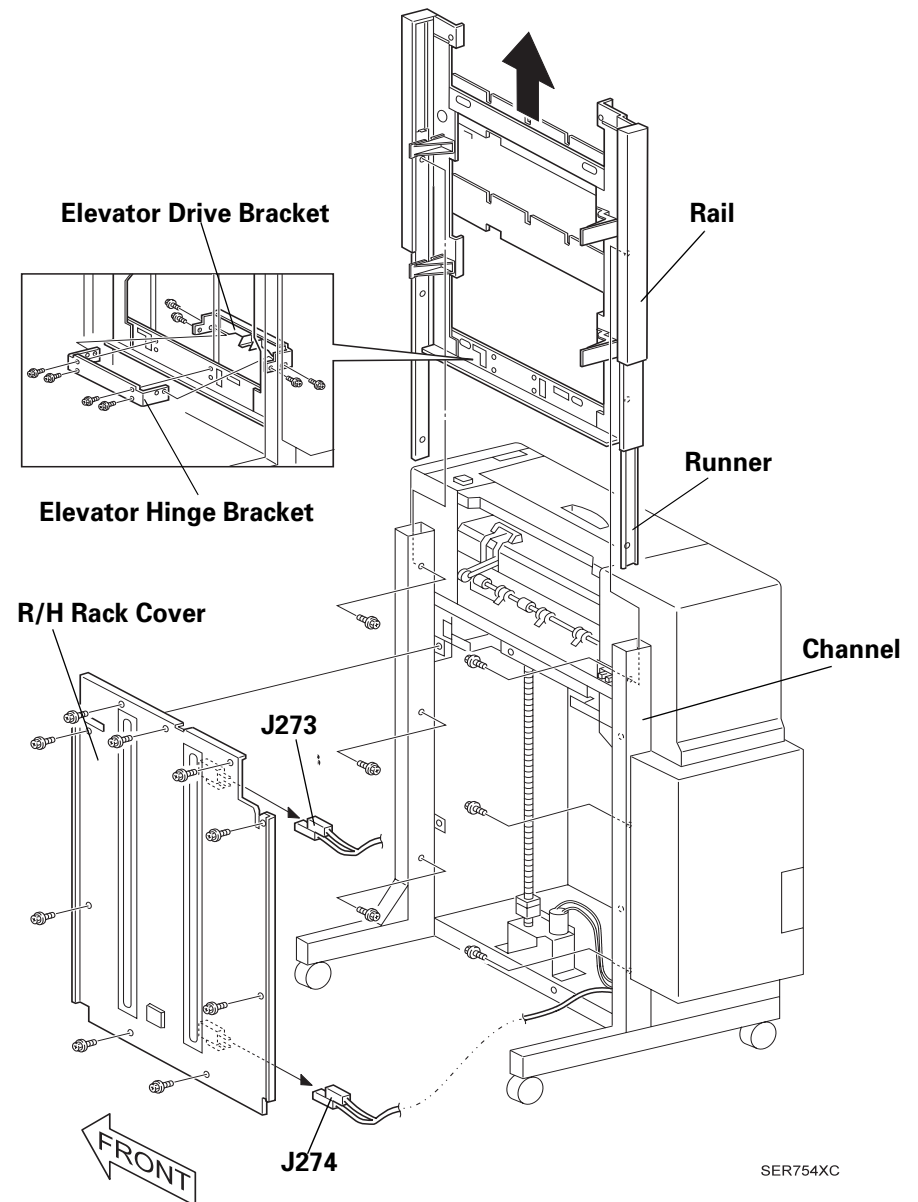

Figure 3-20. R/H Rack Cover Assembly

### 3.4.15.2 Installation

1. Place the R/H Rack Cover close to the HCS frame.
2. Connect J274 to the Lower Limit Switch.
3. Connect J273 to the Upper Limit Switch.
4. Install R/H Rack Cover to the HCS frame and secure it with seven screws.
5. Place the Rail as shown in the Figure 3-20 and slide the two Runners to the grooves on the HCS frame.
6. Secure the Rails to the grooves with six screws.
7. Install the Elevator Hinge Bracket to the R/H Rack Cover and secure it with four screws.
8. Install Elevator Drive Bracket to the Hinge Bracket and secure it with four screws.
9. Install L/H Cover Low. (Refer to "L/H Cover Low" on page 44)
10. Install Top Tray Assembly. (Refer to "Top Tray Assembly" on page 77)
11. Install Middle Tray Assembly. (Refer to "Middle Tray Assembly" on page 67)
12. Install Bottom Tray Assembly. (Refer to "Bottom (Lower) Tray Assembly" on page 57)

### 3.4.16 Stacker Elevator Motor

Refer to the exploded diagram (Figure 4-28, "Rail and Trays" on page 170).

#### 3.4.16.1 Removal

1. Remove L/H Cover Low. (Refer to "L/H Cover Low" on page 44)
2. Remove two screws securing Motor Plate to the Motor Bracket.
3. Slide the Motor Plate to enable Motor Pulley to move freely from the Drive Belt, and remove Motor Plate with Elevator Motor from the Bracket.
4. Pull out J865.
5. Remove the E ring connecting the Motor Pulley to the Motor Shaft and remove the pulley.
6. Remove two screws securing Elevator Motor to the Motor Plate and remove the motor.

#### 3.4.16.2 Installation

1. Place the Elevator Motor against Motor Plate as shown in the Figure 3-21.
2. Secure the Motor to the Plate with two screws.
3. Insert the Motor Pulley into the Motor shaft.
4. Install Pulley to the Motor shaft with E ring.
5. Install Elevator Motor with Motor Plate to the hole of Motor Bracket and hang the Drive Belt around the Motor Pulley.
6. Secure the Motor Plate to the Motor Bracket with two screws.
7. Connect J865.
8. Install L/H Cover Low. (Refer to "L/H Cover Low" on page 44)

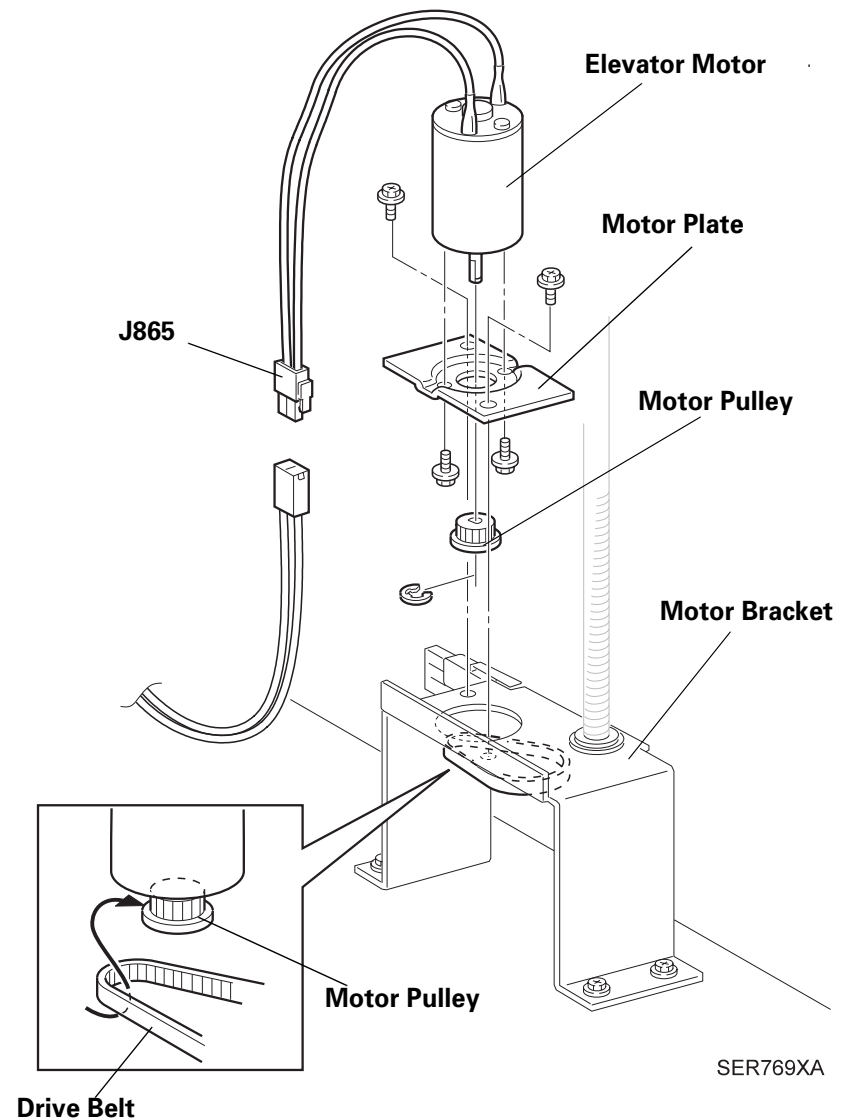

Figure 3-21. Stacker Elevator Motor



### 3.4.17 Bottom (Lower) Tray Assembly

Refer to the exploded diagram (Figure 4-29, "Lower Tray" on page 172).

#### 3.4.17.1 Removal

1. Remove HCS from the printer. (Refer to "Finisher Stapler" on page 35)
2. Remove Harness Cover. (Refer to "Harness Cover" on page 46)
3. Remove Harness Guide Cover at the bottom.
4. Release wires inside the Harness Guide from the clip.
5. Pull out J830A, J871A, J874A, and J875A.
6. Remove a screw securing Harness Guide and remove Harness Guide.
7. Remove two screws at the bottom of the Bottom Tray Assembly, Securing the Assembly to the HCS frame.
8. Loosen two screws at the top of the Bottom Tray Assembly, Securing the Assembly to the HCS frame.
9. Lift the Bottom Tray Assembly off the screws and remove the Assembly from the HCS frame.

#### 3.4.17.2 Installation

1. Hang the Bottom Tray Assembly on the HCS frame as the two screws on the top of the HCS frame go under the screw holes of the Top Tray Assembly.
2. Fasten two screws.
3. Secure the bottom of the Assembly to the HCS frame with two screws.
4. Let the Bottom Tray Assembly wire harness through the slot at the bottom of the Harness Guide.
5. Install the Bottom Harness Guide and secure it to the HCS frame with a screw.
6. Connect J830A, J871A, J874A, and J875A.
7. Secure the wires under the clip.
8. Install Harness Cover. (Refer to "Harness Cover" on page 46)

9. Connect HCS to the printer. (Refer to "Finisher Stapler" on page 35)

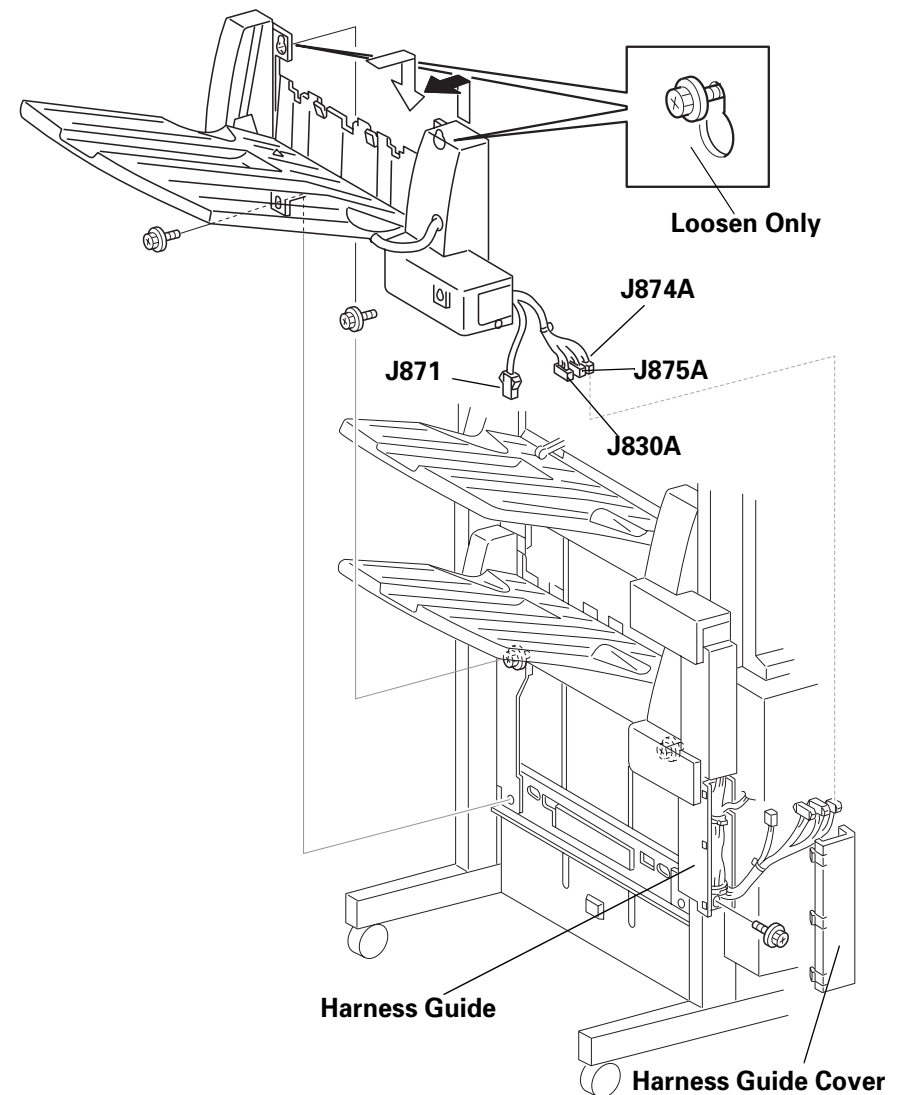

SER758XA

Figure 3-22. Bottom (Lower) Tray Assembly

### 3.4.18 Bottom Tray Front Cover

Refer to the exploded diagram (Figure 4-29, "Lower Tray" on page 172).

#### 3.4.18.1 Removal

1. Remove Bottom Tray Assembly. (Refer to "Bottom (Lower) Tray Assembly" on page 57)
2. Break open Bottom Tray Front Cover and remove the Cover.

#### 3.4.18.2 Installation

1. Install the Front Cover to the Bottom Tray.
2. Install Bottom Tray Assembly. (Refer to "Bottom (Lower) Tray Assembly" on page 57)

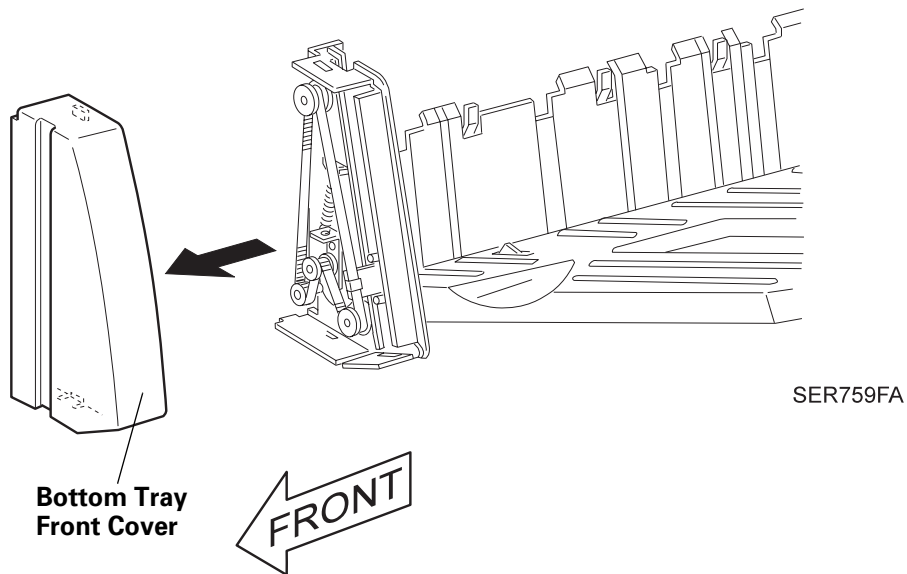

Figure 3-23. Finisher Stapler Interlock Sensor and Actuator

### 3.4.19 Bottom Tray Half and Full Sensors

Refer to the exploded diagram (Figure 4-29, "Lower Tray" on page 172).

#### 3.4.19.1 Removal

1. Remove the Bottom Tray Assembly. (Refer to "Bottom (Lower) Tray Assembly" on page 57)
2. Slide off the Rear Harness Cover from the Bottom Tray Rear.
3. Remove the screw at the bottom of the Bottom Tray Rear Cover, securing the rear cover to the Tray frame.
4. Set the latches at the upper part of the Rear Cover off and remove the Cover.
5. Remove the screw securing Sensor Bracket to the Tray frame and remove the Bracket.
6. Pull out P860 from the Half Sensor.
7. Push the Sensor latches in and release, which connects the Sensor to the Bracket, and remove the Sensor.
8. Pull out P861 from Full Sensor.
9. Push the Sensor latches in and release, which connects the Sensor to the Bracket, and remove the Sensor.

#### 3.4.19.2 Installation

1. Place the Full Sensor as shown in the Figure 3-24 and insert it with latches ahead into the cutouts of the Sensor Bracket and set the latches on.
2. Connect P861 to the Full Sensor.
3. Place the Half Sensor as shown in the Figure 3-24 and insert Half Sensor with latches ahead to the cutouts of the Sensor Bracket and set the latches on.
4. Connect P860 to Full Sensor.
5. Install Sensor Bracket to the Tray frame and secure it to the frame with a screw.

6. First set the latches at the upper part of Rear Cover and then secure it to the Tray frame with a screw.
7. Let the wire harness through the cutout at the back of the Cover and slide the Rear Harness Cover into the Bottom Tray Rear Cover.
8. Install Bottom Tray Assembly. (Refer to "Bottom (Lower) Tray Assembly" on page 57)

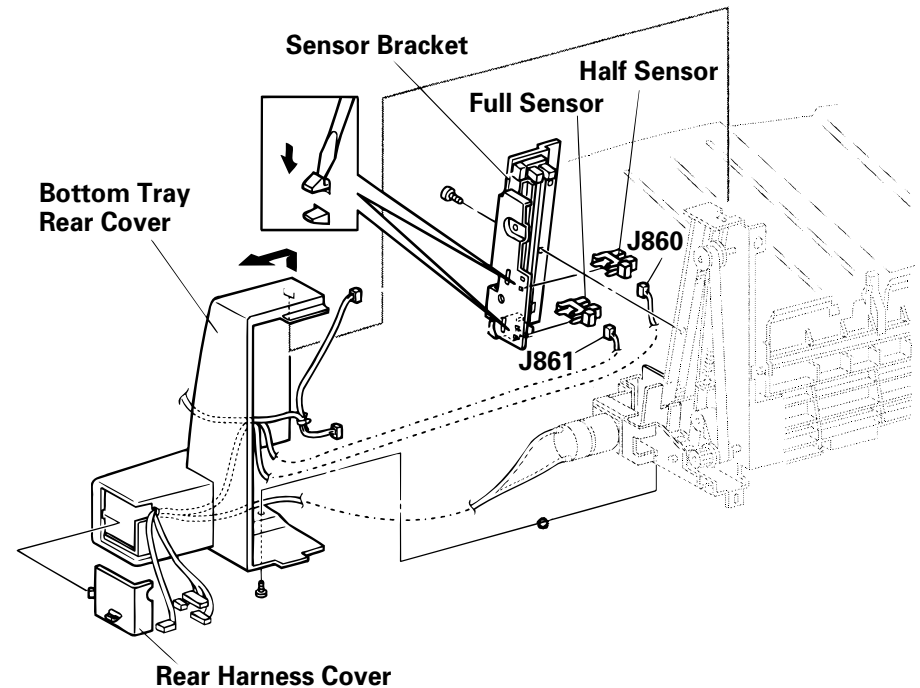

Figure 3-24. Bottom Tray Half and Full Sensors

## 3.4.20 Bottom Tray Lower and Upper Limit Sensor

### 3.4.20.1 Removal

1. Remove the Bottom Tray Assembly. (Refer to "Bottom (Lower) Tray Assembly" on page 57)
2. Slide off Rear Harness Cover from Bottom Tray Rear Cover.
3. Remove the screw on the bottom of the Rear Cover securing Bottom Tray Rear Cover to the Tray frame.
4. Release the latches at the upper part of the Rear Cover and remove the Cover.
5. Remove screws securing Sensor Bracket to the Tray frame and remove the Sensor Bracket.
6. Pull out P850 from the Upper Limit Sensor.
7. Push the Sensor latches in and release, which connects the Sensor to the Bracket, and remove the Sensor.
8. Pull out P851 from Lower Limit Sensor.
9. Push the Sensor latches in and release, which connects the Sensor to the Bracket, and remove the Sensor.

### 3.4.20.2 Installation

1. Place the Lower Limit Sensor as shown in the Figure 3-25 and insert it with latches ahead into the cutouts of the Sensor Bracket and set the latches on.
2. Connect P851 to the Full Sensor.
3. Place the Upper Limit Sensor as shown in the Figure 3-24 and insert it with latches ahead into the cutouts of the Sensor Bracket and set the latches on.
4. Connect P850 to Full Sensor.
5. Install Sensor Bracket to the Tray frame and secure it to the frame with a screw.
6. First set the latches at the upper part of Rear Cover and then secure it to the Tray frame with a screw.

7. Let the wire harness through the cutout at the back of the Cover and slide the Rear Harness Cover into the Bottom Tray Rear Cover.
8. Install Bottom Tray Assembly. (Refer to "Bottom (Lower) Tray Assembly" on page 57)

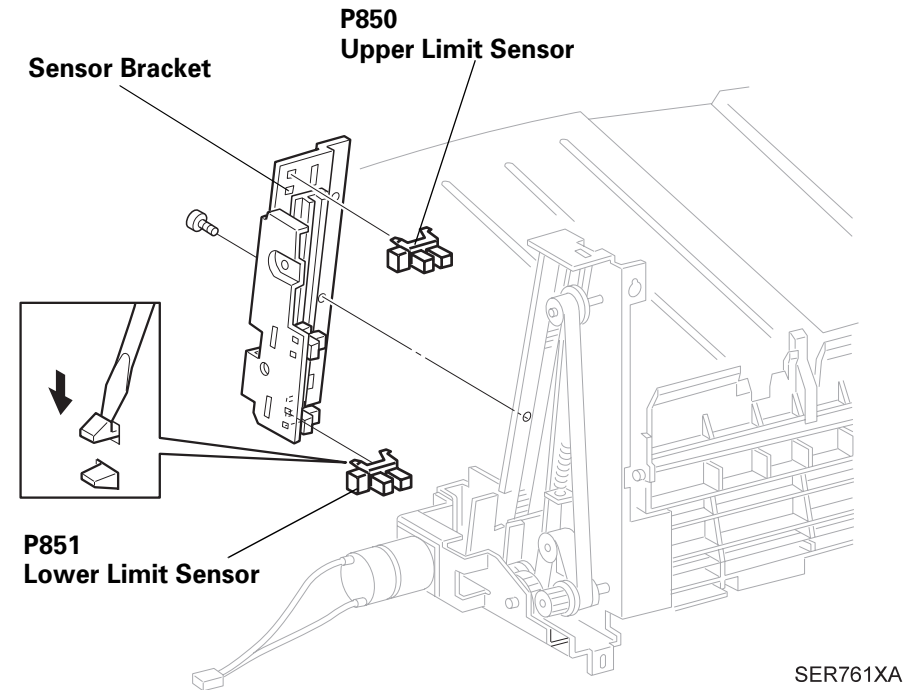

Figure 3-25. Bottom Tray Lower and Upper Limit Sensor

### 3.4.21 Bottom Tray

Refer to the exploded diagram (Figure 4-29, "Lower Tray" on page 172).

#### 3.4.21.1 Removal

1. Remove Bottom Tray Assembly. (Refer to "Bottom (Lower) Tray Assembly" on page 57)
2. Remove Bottom Tray Drive Belts. (Refer to "Bottom Tray Drive Belts" on page 65)
3. Remove Bottom Tray Paper Sensor. (Refer to "Bottom Tray Paper Sensor" on page 62)
4. Remove Bottom Tray Safety Sensor. (Refer to "Bottom Tray Safety Sensor" on page 63)
5. Remove screw securing Sensor wire harness to the bottom of the Tray and remove the harness.
6. Remove the Tray by sliding it off from the grooves of the Front Tray frame and the Rear Tray frame. (Figure 1)
7. Remove four screws securing the Carriage to the Tray and remove the Tray. (Figure 2)

#### 3.4.21.2 Installation

1. Install the Carriage to the Tray and secure it with four screws.
2. Install the Tray into the grooves of Front Tray Frame and Rear Tray Frame.
3. Install Sensor wire harness to the bottom of the Tray and secure it with screw.
4. Install Bottom Tray Safety Sensor. (Refer to "Bottom Tray Safety Sensor" on page 63)
5. Install Bottom Tray Paper Sensor. (Refer to "Bottom Tray Paper Sensor" on page 62)
6. Install Bottom Tray Drive Belts. (Refer to "Bottom Tray Drive Belts" on page 65) to the both sides of the frame.

7. Install Bottom Tray Assembly. (Refer to "Bottom (Lower) Tray Assembly" on page 57)

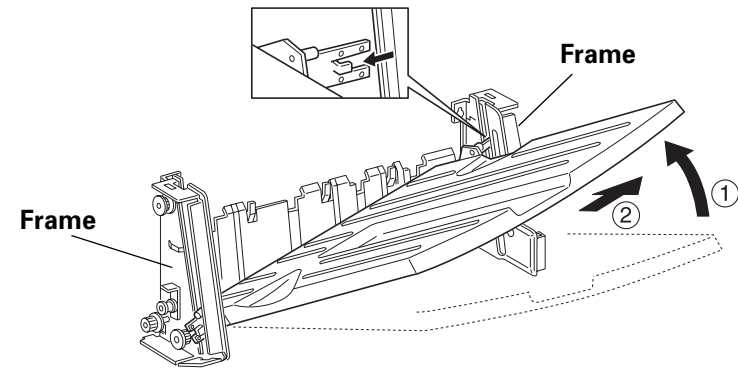

Figure 1

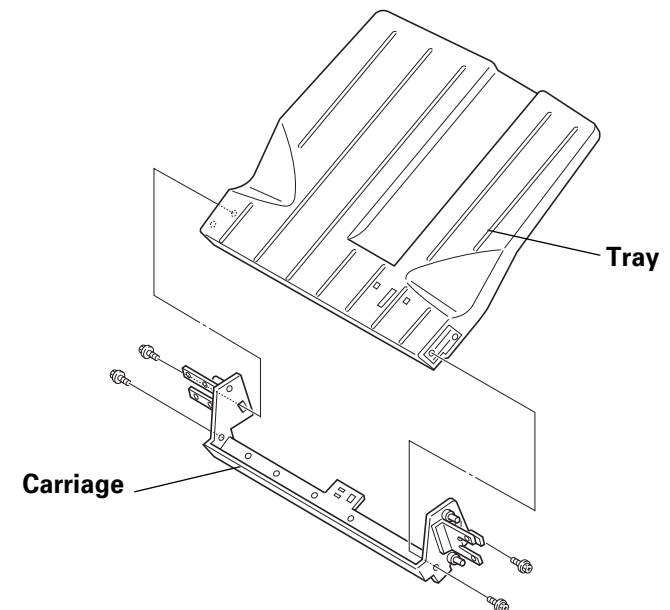

Figure 2

SER765XB

Figure 3-26. Bottom Tray

### 3.4.22 Bottom Tray Paper Sensor

Refer to the exploded diagram (Figure 4-29, "Lower Tray" on page 172).

#### 3.4.22.1 Removal

1. Remove Bottom Tray Assembly. (Refer to "Bottom (Lower) Tray Assembly" on page 57)
2. Remove three screws securing Back Cover to the Tray and remove the Cover.
3. Remove a screw securing Paper Sensor Bracket to the Tray and remove the Sensor Bracket along with Paper Sensor.
4. Pull out J859 from the Sensor.
5. Push the Sensor latches in and release, which connects the sensor to the bracket, and remove the sensor.

#### 3.4.22.2 Installation

1. Place the Bottom Tray Paper Sensor as shown in the Figure 3-27 and insert it with the latches ahead into the cutouts of the Sensor Bracket and set the latches on.
2. Connect J859 to the Sensor.
3. Ensure position-marking tabs on the Tray comes into the holes of the Bracket and install the Sensor Bracket to the Tray.
4. Secure the Bracket to the Tray with a screw.
5. Install the Back Cover to the Tray and secure it with three screws.
6. Install Bottom Tray Assembly. (Refer to "Bottom (Lower) Tray Assembly" on page 57)

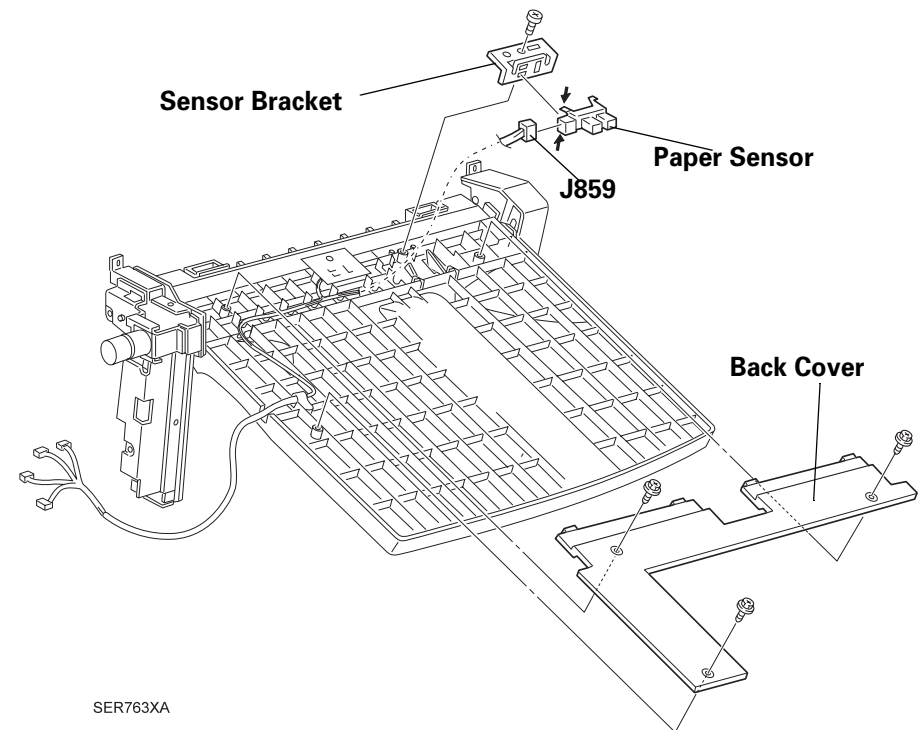

**Figure 3-27. Bottom Tray Paper Sensor**

### 3.4.23 Bottom Tray Safety Sensor

Refer to the exploded diagram (Figure 4-29, "Lower Tray" on page 172).

#### 3.4.23.1 Removal

1. Remove the Bottom Tray Assembly. (Refer to "Bottom (Lower) Tray Assembly" on page 57)
2. Remove three screws securing the Back Cover to the Tray and remove the Cover.
3. Remove the screw securing the Safety Sensor Bracket to the Tray and remove the Bracket along with the Safety Sensor.
4. Pull out the J831 from the Sensor.
5. Push in the Sensor latches in and release, which connects the Sensor to the Bracket, and remove the Sensor.

#### 3.4.23.2 Installation

1. Place the Bottom Tray Safety Sensor as shown in the Figure 3-28 and insert it with the latches ahead into the cutouts of the Sensor Bracket and set the latches on.
2. Connect J831 to the Sensor.
3. Ensure position-marking tabs on the Tray comes into the holes of the Bracket and install the Sensor Bracket to the Tray.
4. Secure the Bracket to the Tray with a screw.
5. Install the Back Cover to the Tray and secure it with three screws.
6. Install Bottom Tray Assembly. (Refer to "Bottom (Lower) Tray Assembly" on page 57)

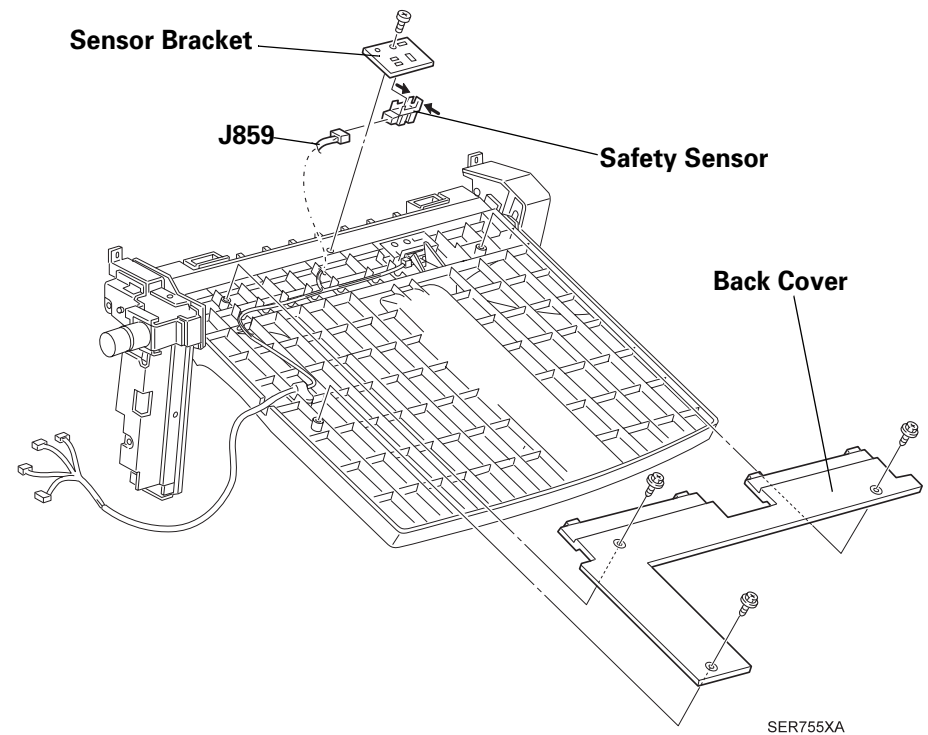

Figure 3-28. Bottom Tray

### 3.4.24 Bottom Tray Motor

Refer to the exploded diagram (Figure 4-29, "Lower Tray" on page 172).

#### 3.4.24.1 Removal

1. Remove the Bottom Tray Assembly. (Refer to "Bottom (Lower) Tray Assembly" on page 57)
2. Remove Rear Harness Cover from the Bottom Tray Rear Cover by sliding it off.
3. Remove the screw at the bottom of the Rear Cover securing Bottom Tray Rear Cover to the Tray Frame.
4. Release the latches at the upper part of the Rear Cover and remove the Cover.
5. Remove four screws securing the Motor Bracket to the Tray and remove the Bracket along with the Motor.
6. Remove the E ring binding Gear to the Motor shaft and remove the Shaft Gear.
7. Remove two screws securing the Motor to the Bracket and remove the Motor.

#### 3.4.24.2 Installation

1. Install the Motor to the Motor Bracket and secure it with two screws.
2. Install the Gear to the end of Motor Shaft.
3. Secure the Gear to the Shaft with E ring.
4. Install the Bracket along with the Motor to the Tray frame and secure it with four screws.
5. Set the latches on the top of the Rear Cover and then secure it to the Tray frame with a screw.
6. Let the wire harness through the cutouts on the back of the Cover and install Rear Harness Cover by sliding.
7. Install Bottom Tray Assembly. (Refer to "Bottom (Lower) Tray Assembly" on page 57)

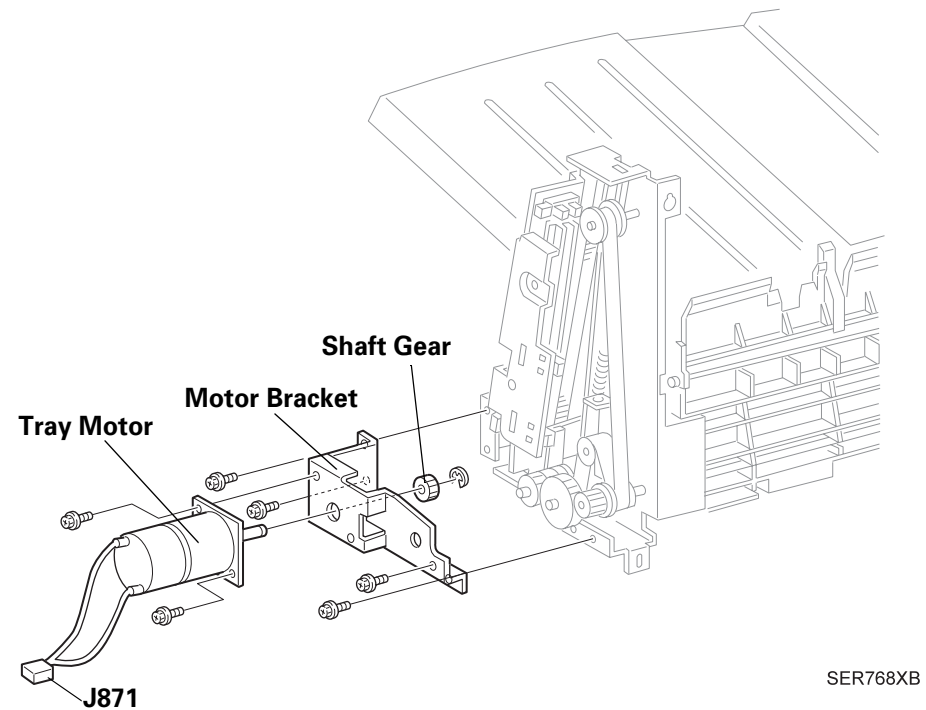

Figure 3-29. Bottom Tray Motor

SER768XB



### 3.4.25 Bottom Tray Drive Belts

Refer to the exploded diagram (Figure 4-30, "Lower Tray Frame" on page 173).

#### 3.4.25.1 Removal

1. Remove the Bottom Tray Assembly. (Refer to "Bottom (Lower) Tray Assembly" on page 57)
2. Remove the Bottom Tray Front Cover. (Refer to "Bottom Tray Front Cover" on page 58)
3. Remove the Tension Spring from the Tension Plate. (Figure 3-30)
4. Remove two screws securing Tension Plate to the Tray frame and remove the Plate.
5. Remove two screws securing Belt Clamp to the Tray and remove the Clamp.
6. Remove the Belt from the Clamp by sliding.
7. Remove the E ring binding the Drive Gear to the Shaft and remove the Gear.
8. Remove the Front Drive Gear.
9. Remove the Bottom Tray Motor. (Refer to "Bottom Tray Motor" on page 64)
10. Remove the screw securing the Sensor Bracket to the Tray frame and remove the Bracket.
11. Remove the Tension Spring from the Tension Plate. (Figure 3-31)
12. Remove two screws securing the Limit Actuator to the Tray frame and remove the Actuator.
13. Remove two screws securing the Tension Plate to the Tray frame and remove the Tension Plate.
14. Remove two screws securing the Belt Clamp to the Tray frame and remove the Belt Clamp.
15. Remove the Belt from the Clamp by sliding.
16. Remove the E ring binding the Drive Gear to the shaft and remove the Drive Gear.
17. Remove the Rear Drive Belt.

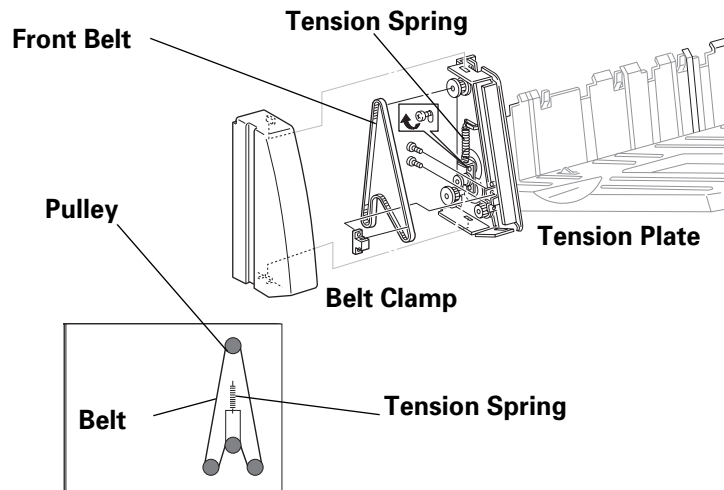

SER815XB1

Figure 3-30. Front Drive Belt

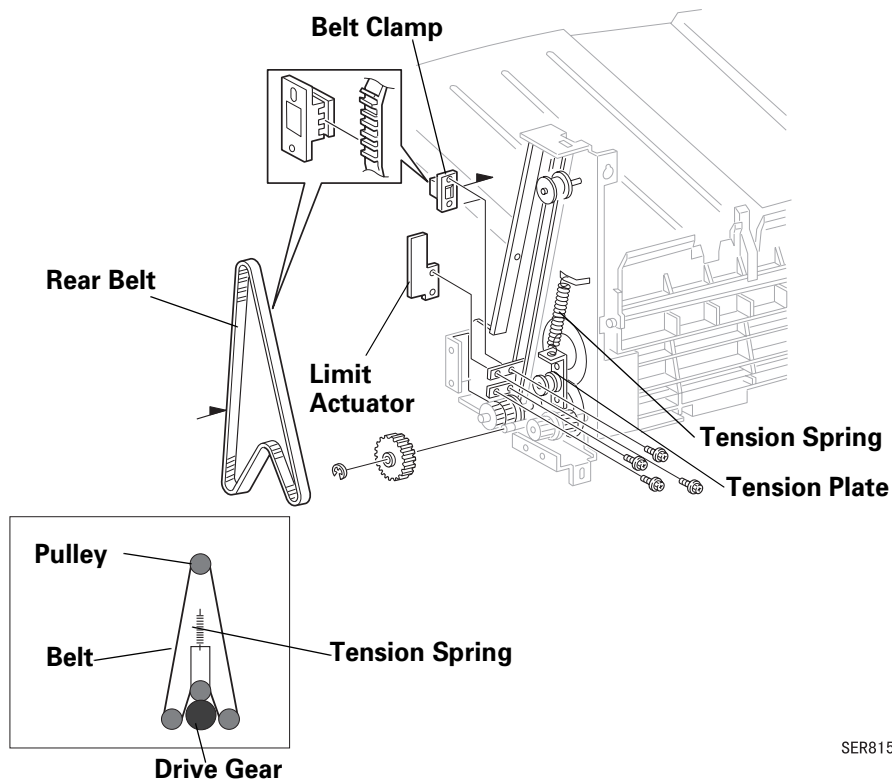

SER815XB2

Figure 3-31. Rear Drive Belt

### 3.4.25.2 Installation

1. Install the Rear Drive Belt as shown in the Figure 3-31.
2. Install the Drive Gear to the shaft and secure it with E ring.
3. Slide the Rear Belt around the Clamp.
4. Secure the Clamp to the Tray frame with two screws.
5. Install the Tension Plate to the frame and secure it with two screws.
6. Install the Limit Actuator to the frame and secure it with two screws.
7. Hang the Tension Spring on the Tension Plate.
8. Install the Sensor Bracket to the Tray frame and secure it with a screw.

9. Install the Bottom Tray Motor. (Refer to "Bottom Tray Motor" on page 64)
10. Install the Front Drive Belt as shown in the Figure 3-30.
11. Install the Rear Belt to the Clamp by sliding.
12. Secure the Clamp to the Tray frame with two screws.
13. Install the Tension Plate to the frame and secure it with two screws.
14. Hang the Tension Spring to the Tension Plate.
15. Install the Bottom Tray Front Cover. (Refer to "Bottom Tray Front Cover" on page 58)
16. Install Bottom Tray Assembly. (Refer to "Bottom (Lower) Tray Assembly" on page 57)

### 3.4.26 Middle Tray Assembly

Refer to the exploded diagram (Figure 4-31, "Middle Tray" on page 175).

#### 3.4.26.1 Removal

1. Remove the HCS from the printer. (Refer to "Finisher Stapler" on page 35)
2. Remove the Harness Cover. (Refer to "Harness Cover" on page 46)
3. Remove the bottom Harness Guide Cover.
4. Release wires under the Harness Guide from the clip.
5. Pull out J887A, J870, J872A, and J873A.
6. Remove the screw securing bottom Harness Guide and remove the Bottom Harness Guide.
7. Remove the top Harness Guide Cover.
8. Remove the screw holding top Harness Guide and remove the top Harness Guide.
9. Remove two screws on the bottom of the Middle Tray Assembly securing the Assembly to the HCS frame.
10. Loosen two screws on the top of the Middle Tray Assembly securing the Assembly to the HCS frame.
11. Lift the Middle Tray Assembly out of two screw holes and remove the Assembly from the HCS frame.

#### 3.4.26.2 Installation

1. Hang the Middle Tray Assembly on two screws on the top of HCS frame.
2. Fasten the screws.
3. Secure the bottom of the Assembly to the HCS frame with two screws.
4. Let the Middle Tray Assembly wire harness through the slot on the bottom of the Harness Guide.
5. Install the Top Harness Guide and secure it to the HCS frame with a screw.

6. Install the top Harness Guide Cove.
7. Install the bottom Harness Guide and secure it to the HCS frame with a screw.
8. Connect J877A, J870, J872A, and J873A.
9. Secure wires under the clip.
10. Install the bottom Harness Guide Cover.
11. Install the Harness Cover. (Refer to "Harness Cover" on page 46)
12. Install Bottom Tray Assembly. (Refer to "Bottom (Lower) Tray Assembly" on page 57)

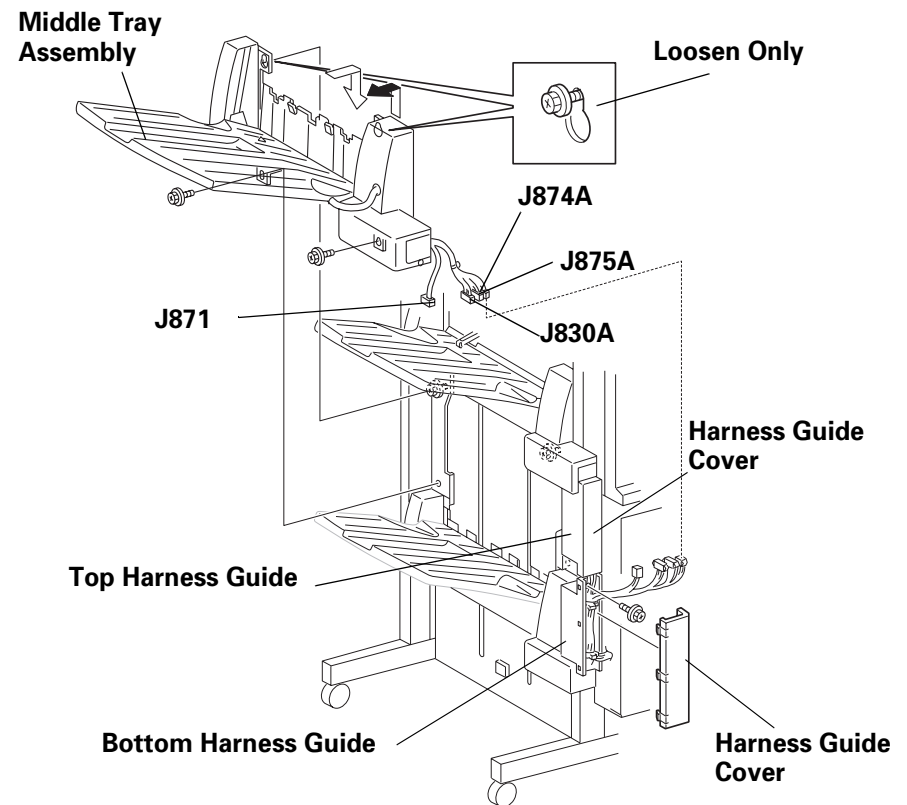

SER757XA

Figure 3-32. Middle Tray Assembly

### 3.4.27 Middle Tray Front Cover

Refer to the exploded diagram (Figure 4-31, "Middle Tray" on page 175).

#### 3.4.27.1 Removal

1. Remove the Middle Tray Assembly. (Refer to "Middle Tray Assembly" on page 67)
2. Break open the Middle Tray Front Cover and remove the cover.

#### 3.4.27.2 Installation

1. Install the Front Cover to the Middle Tray.
2. Install Middle Tray Assembly. (Refer to "Middle Tray Assembly" on page 67)

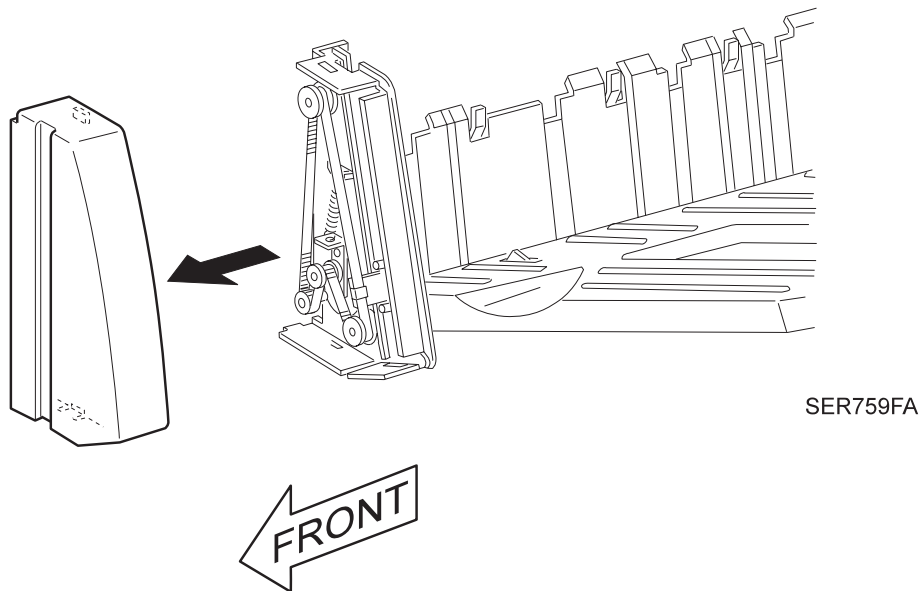

Figure 3-33. Middle Tray Front Cover

### 3.4.28 Middle Tray Half and Full Sensors

Refer to the exploded diagram (Figure 4-31, "Middle Tray" on page 175).

#### 3.4.28.1 Removal

1. Remove the Middle Tray Assembly. (Refer to "Middle Tray Assembly" on page 67)
2. Slide off the Rear Harness Cover from the Middle Tray Rear.
3. Remove the screw at the bottom of the Middle Tray Rear Cover, securing the rear cover to the Tray frame.
4. Set the latches at the upper part of the Rear Cover off and remove the Cover.
5. Remove the screw securing Sensor Bracket to the Tray frame and remove the Bracket.
6. Pull out P857 from the Half Sensor.
7. Push the Sensor latches in and release, which connects the Sensor to the Bracket, and remove the Sensor.
8. Pull out P858 from Full Sensor.
9. Push the Sensor latches in and release, which connects the Sensor to the Bracket, and remove the Sensor.

#### 3.4.28.2 Installation

1. Place the Full Sensor as shown in the Figure 3-34 and insert it with latches ahead into the cutouts of the Sensor Bracket and set the latches on.
2. Connect P858 to the Full Sensor.
3. Place the Half Sensor as shown in the Figure 3-34 and insert Half Sensor with latches ahead to the cutouts of the Sensor Bracket and set the latches on.
4. Connect P857 to Full Sensor.
5. Install Sensor Bracket to the Tray frame and secure it to the frame with a screw.

6. First set the latches at the upper part of Rear Cover and then secure it to the Tray frame with a screw.
7. Let the wire harness through the cutout at the back of the Cover and slide the Rear Harness Cover into the Bottom Tray Rear Cover.
8. Install Middle Tray Assembly. (Refer to "Middle Tray Assembly" on page 67)

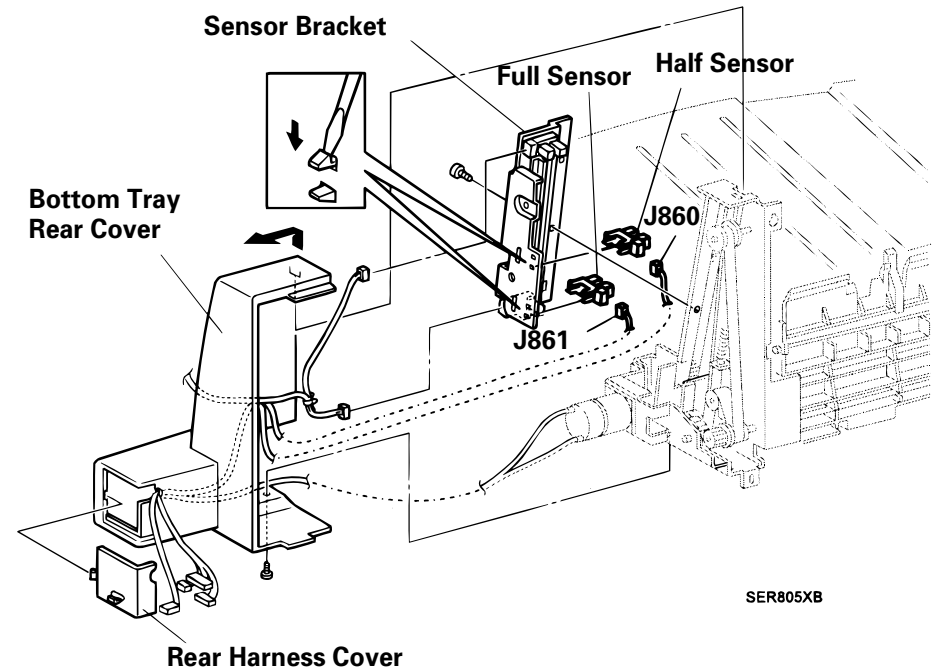

Figure 3-34. Middle Tray Half and Full Sensors

### 3.4.29 Middle Tray Lower and Upper Limit Sensor

Refer to the exploded diagram (Figure 4-31, "Middle Tray" on page 175).

#### 3.4.29.1 Removal

1. Remove the Top Tray Assembly. (Refer to "Middle Tray Assembly" on page 67)
2. Slide off Rear Harness Cover from Middle Tray Rear Cover.
3. Remove the screw on the bottom of the Rear Cover securing Top Tray Rear Cover to the Tray frame.
4. Release the latches at the upper part of the Rear Cover and remove the Cover.
5. Remove screws securing Sensor Bracket to the Tray frame and remove the Sensor Bracket.
6. Pull out P848 from the Upper Limit Sensor.
7. Push the Sensor latches in and release, which connects the Sensor to the Bracket, and remove the Sensor.
8. Pull out P849 from Lower Limit Sensor.
9. Push the Sensor latches in and release, which connects the Sensor to the Bracket, and remove the Sensor.

#### 3.4.29.2 Installation

1. Place the Lower Limit Sensor as shown in the Figure 3-35 and insert it with latches ahead into the cutouts of the Sensor Bracket and set the latches on.
2. Connect P849 to the Lower Limit Sensor.
3. Place the Upper Limit Sensor as shown in the Figure 3-35 and insert it with latches ahead into the cutouts of the Sensor Bracket and set the latches on.
4. Connect P848 to Upper Limit Sensor.
5. Install Sensor Bracket to the Tray frame and secure it to the frame with a screw.

6. First set the latches at the upper part of Rear Cover and then secure it to the Tray frame with a screw.
7. Let the wire harness through the cutout at the back of the Cover and slide the Rear Harness Cover into the Bottom Tray Rear Cover.
8. Install Middle Tray Assembly. (Refer to "Middle Tray Assembly" on page 67)

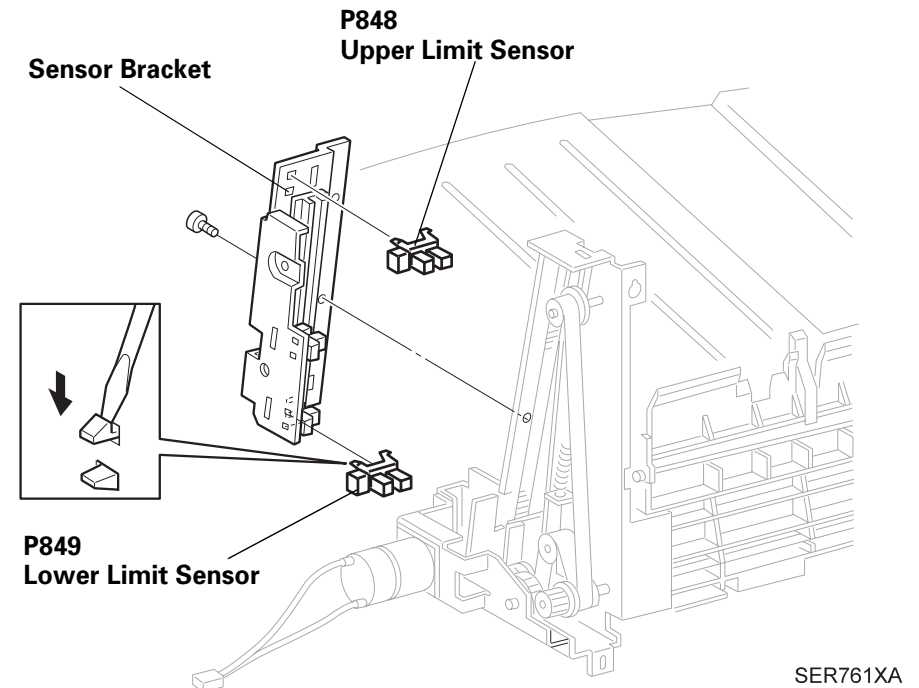

Figure 3-35. Middle Tray Lower and Upper Limit Sensor

### 3.4.30 Middle Tray

Refer to the exploded diagram (Figure 4-31, "Middle Tray" on page 175).

#### 3.4.30.1 Removal

1. Remove Middle Tray Assembly. (Refer to "Middle Tray Assembly" on page 67)
2. Remove Middle Tray Drive Belts. (Refer to "Middle Tray Drive Belts" on page 74)
3. Remove Middle Tray Paper Sensor. (Refer to "Middle Tray Paper Sensor" on page 72)
4. Remove screw securing Sensor wire harness to the bottom of the Tray and remove the harness.
5. Remove the Tray by sliding it off from the grooves of the Front Tray frame and the Rear Tray frame. (Figure 1)
6. Remove four screws securing the Carriage to the Tray and remove the Tray. (Figure 2)

#### 3.4.30.2 Installation

1. Install the Carriage to the Tray and secure it with four screws.
2. Install the Tray into the grooves of Front Tray Frame and Rear Tray Frame.
3. Install Sensor wire harness to the bottom of the Tray and secure it with screw.
4. Install Middle Tray Paper Sensor. (Refer to "Middle Tray Paper Sensor" on page 72)
5. Install Middle Tray Drive Belts. (Refer to "Middle Tray Drive Belts" on page 74) to the both sides of the frame.
6. Install Middle Tray Assembly. (Refer to "Middle Tray Assembly" on page 67)

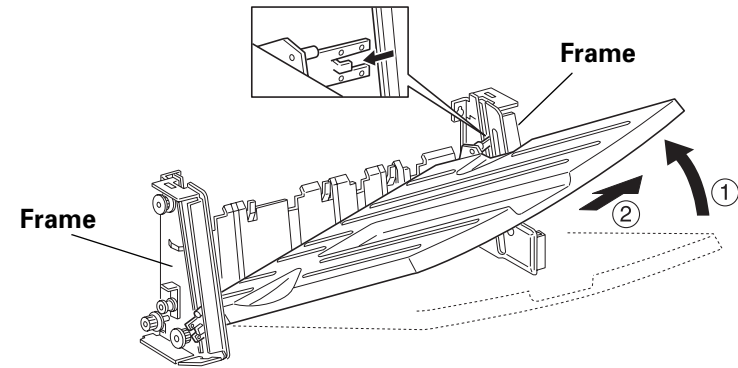

Figure 1

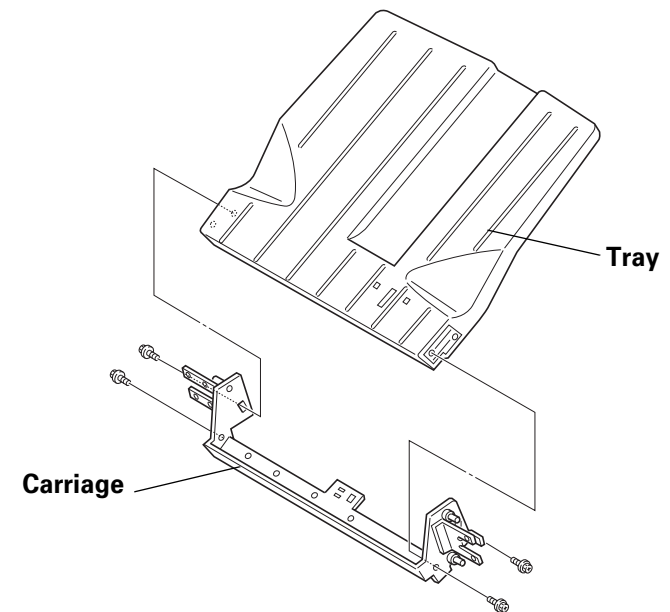

Figure 2

SER765XB

Figure 3-36. Middle Tray

### 3.4.31 Middle Tray Paper Sensor

Refer to the exploded diagram (Figure 4-31, "Middle Tray" on page 175).

#### 3.4.31.1 Removal

1. Remove Middle Tray Assembly. (Refer to "Middle Tray Assembly" on page 67)
2. Remove three screws securing Back Cover to the Tray and remove the Cover.
3. Remove a screw securing Paper Sensor Bracket to the Tray and remove the Sensor Bracket along with Paper Sensor.
4. Pull out J856 from the Sensor.
5. Push the Sensor latches in and release, which connects the sensor to the bracket, and remove the sensor.

#### 3.4.31.2 Installation

1. Place the Middle Tray Paper Sensor as shown in the Figure 3-37 and insert it with the latches ahead into the cutouts of the Sensor Bracket and set the latches on.
2. Connect J856 to the Sensor.
3. Ensure position-marking tabs on the Tray comes into the holes of the Bracket and install the Sensor Bracket to the Tray.
4. Secure the Bracket to the Tray with a screw.
5. Install the Back Cover to the Tray and secure it with three screws.
6. Install Middle Tray Assembly. (Refer to "Middle Tray Assembly" on page 67)

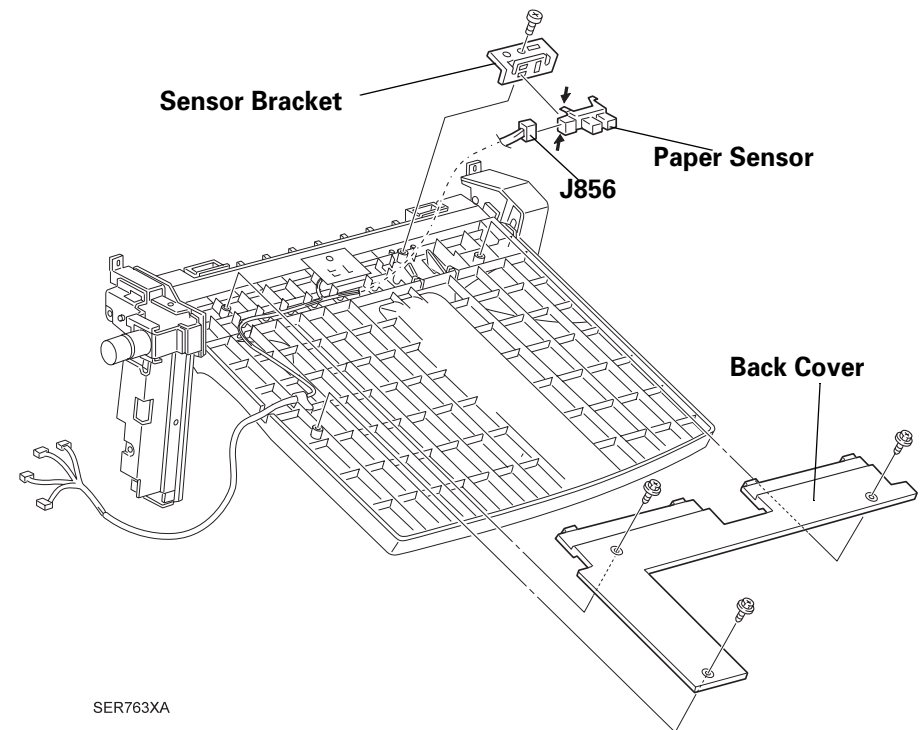

**Figure 3-37. Middle Tray Paper Sensor**



### 3.4.32 Middle Tray Motor

Refer to the exploded diagram (Figure 4-31, "Middle Tray" on page 175).

#### 3.4.32.1 Removal

1. Remove the Middle Tray Assembly. (Refer to "Middle Tray Assembly" on page 67)
2. Remove Rear Harness Cover from the Middle Tray Rear Cover by sliding it off.
3. Remove the screw at the bottom of the Rear Cover securing Middle Tray Rear Cover to the Tray Frame.
4. Release the latches at the upper part of the Rear Cover and remove the Cover.
5. Remove four screws securing the Motor Bracket to the Tray and remove the Bracket along with the Motor.
6. Remove the E ring binding Gear to the Motor shaft and remove the Shaft Gear.
7. Remove two screws securing the Motor to the Bracket and remove the Motor.

#### 3.4.32.2 Installation

1. Install the Motor to the Motor Bracket and secure it with two screws.
2. Install the Gear to the end of Motor Shaft.
3. Secure the Gear to the Shaft with E ring.
4. Install the Bracket along with the Motor to the Tray frame and secure it with four screws.
5. Set the latches on the top of the Rear Cover and then secure it to the Tray frame with a screw.
6. Let the wire harness through the cutouts on the back of the Cover and install Rear Harness Cover by sliding.
7. Install Middle Tray Assembly. (Refer to "Middle Tray Assembly" on page 67)

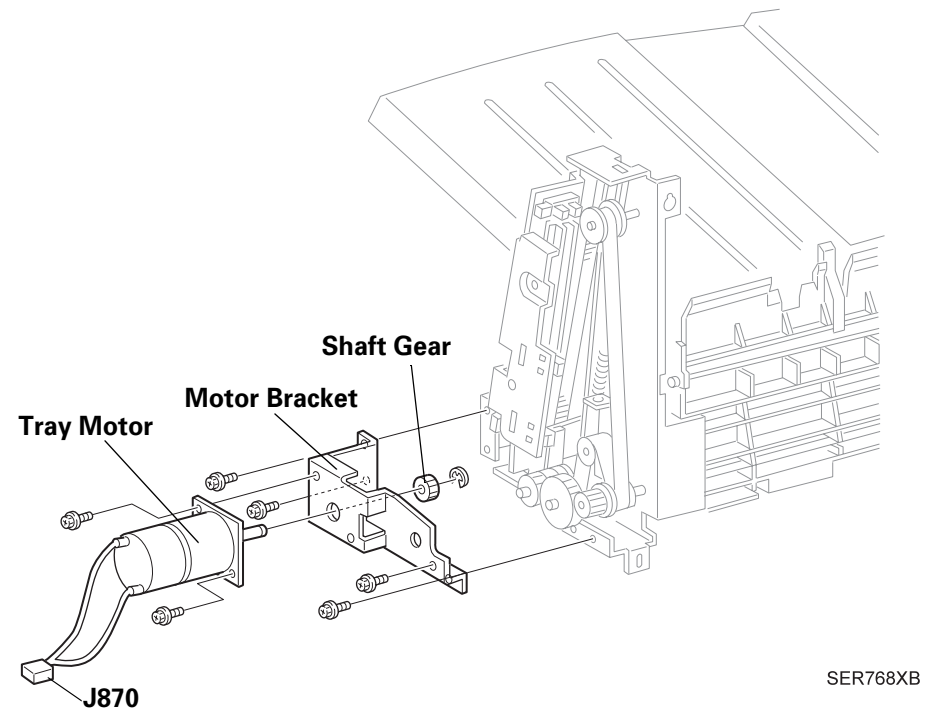

Figure 3-38. Middle Tray Motor

SER768XB

### 3.4.33 Middle Tray Drive Belts

Refer to the exploded diagram (Figure 4-31, "Middle Tray" on page 175).

#### 3.4.33.1 Removal

1. Remove the Middle Tray Assembly. (Refer to "Middle Tray Assembly" on page 67)
2. Remove the Middle Tray Front Cover. (Refer to "Middle Tray Front Cover" on page 68)
3. Remove the Tension Spring from the Tension Plate. (Figure 3-30)
4. Remove two screws securing Tension Plate to the Tray frame and remove the Plate.
5. Remove two screws securing Belt Clamp to the Tray and remove the Clamp.
6. Remove the Belt from the Clamp by sliding.
7. Remove the E ring binding the Drive Gear to the Shaft and remove the Gear.
8. Remove the Front Drive Gear.

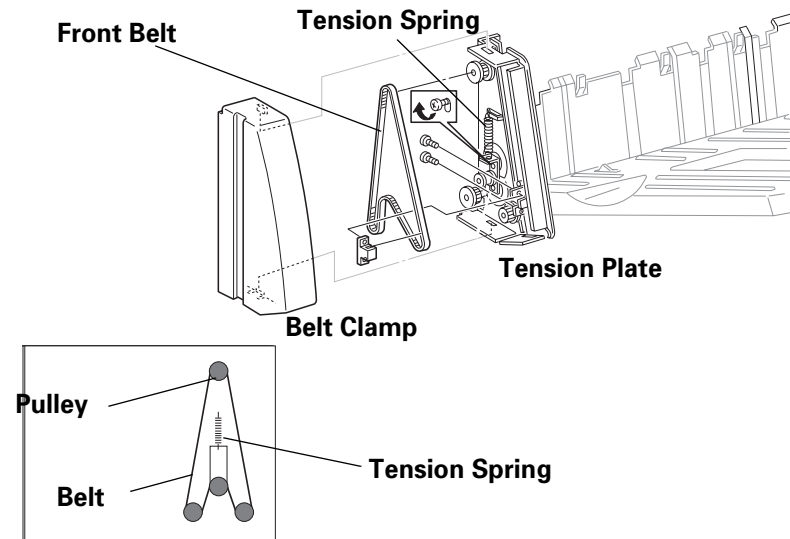

**Figure 3-39. Front Drive Belt**

9. Remove the Middle Tray Motor. (Refer to "Middle Tray Motor" on page 73)
10. Remove the screw securing the Sensor Bracket to the Tray frame and remove the Bracket.
11. Remove the Tension Spring from the Tension Plate. (Figure 3-31)
12. Remove two screws securing the Limit Actuator to the Tray frame and remove the Actuator.
13. Remove two screws securing the Tension Plate to the Tray frame and remove the Tension Plate.
14. Remove two screws securing the Belt Clamp to the Tray frame and remove the Belt Clamp.
15. Remove the Belt from the Clamp by sliding.
16. Remove the E ring binding the Drive Gear to the shaft and remove the Drive Gear.
17. Remove the Rear Drive Belt.

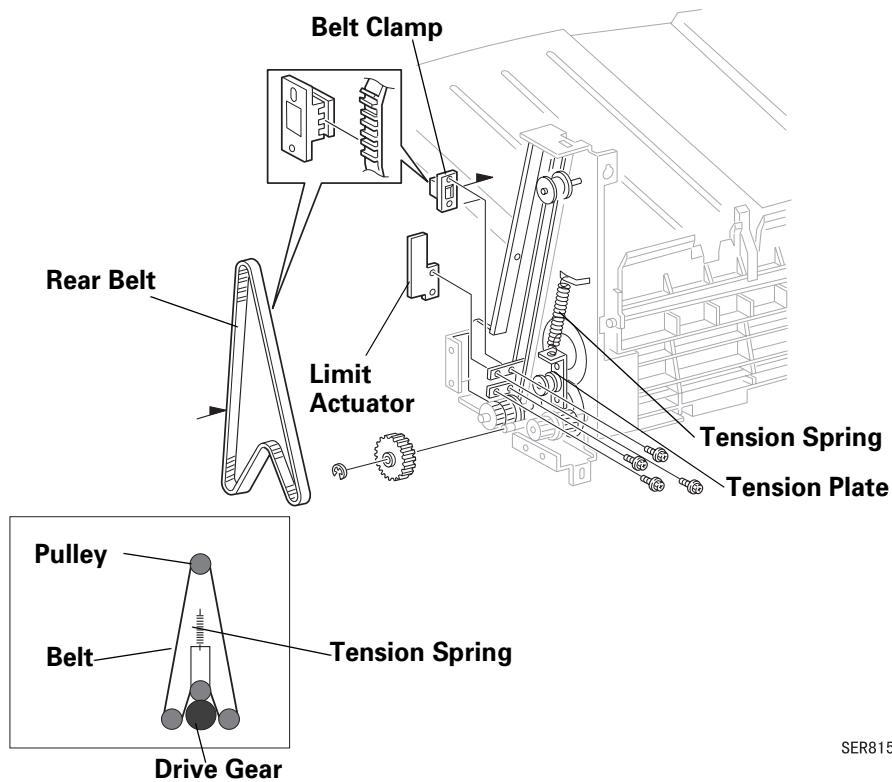

SER815XB2

Figure 3-40. Rear Drive Belt

### 3.4.33.2 Installation

1. Install the Rear Drive Belt as shown in the Figure 3-31.
2. Install the Drive Gear to the shaft and secure it with E ring.
3. Slide the Rear Belt around the Clamp.
4. Secure the Clamp to the Tray frame with two screws.
5. Install the Tension Plate to the frame and secure it with two screws.
6. Install the Limit Actuator to the frame and secure it with two screws.
7. Hang the Tension Spring on the Tension Plate.
8. Install the Sensor Bracket to the Tray frame and secure it with a screw.

9. Install the Middle Tray Motor. (Refer to "Middle Tray Motor" on page 73)
10. Install the Front Drive Belt as shown in the Figure 3-30.
11. Install the Rear Belt to the Clamp by sliding.
12. Secure the Clamp to the Tray frame with two screws.
13. Install the Tension Plate to the frame and secure it with two screws.
14. Hang the Tension Spring to the Tension Plate.
15. Install the Middle Tray Front Cover. (Refer to "Middle Tray Front Cover" on page 68)
16. Install Middle Tray Assembly. (Refer to "Middle Tray Assembly" on page 67)

### 3.4.34 Middle Tray Safety Switch

Refer to the exploded diagram (Figure 4-31, "Middle Tray" on page 175).

#### 3.4.34.1 Removal

1. Remove the Middle Tray Front Cover. (Refer to "Middle Tray Front Cover" on page 68)
2. Pull out J285A from the Safety Switch.
3. Remove two screws securing the Switch to the Tray frame and remove the switch.

#### 3.4.34.2 Installation

1. Install the Middle Tray Safety Switch to the Middle Tray Front Cover.
2. Ensure Switch Actuator is under the resinous Link.
3. Secure the Switch to the Tray frame with two screws.
4. Connect J285A to the Safety Switch.
5. Install Middle Tray Front Cover. (Refer to "Middle Tray Front Cover" on page 68)

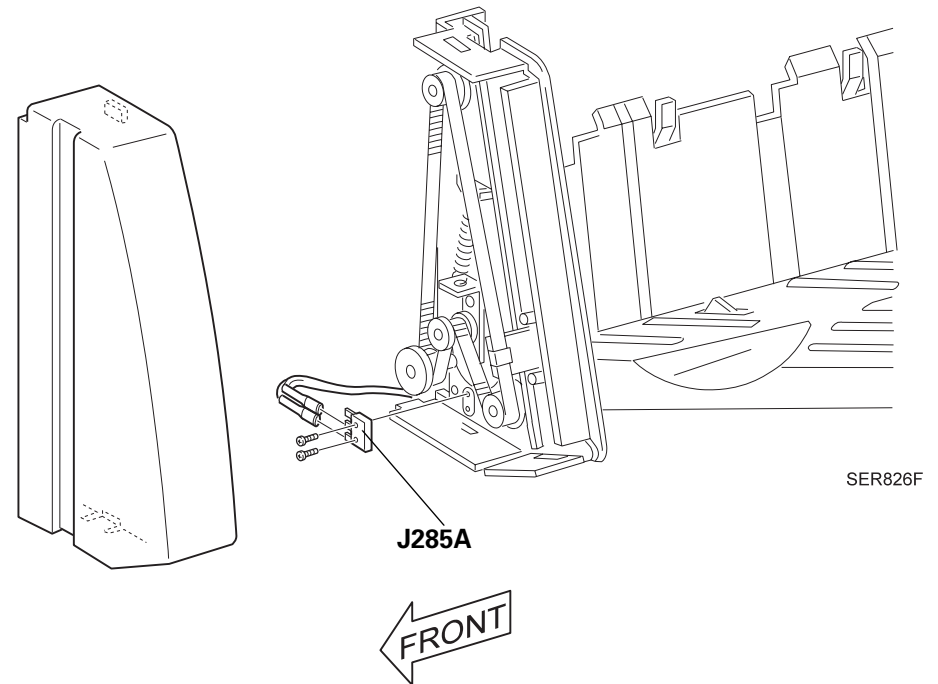

Figure 3-41. Middle Tray Front Cover

### 3.4.35 Top Tray Assembly

Refer to the exploded diagram (Figure 4-33, "Top Tray" on page 179).

#### 3.4.35.1 Removal

1. Remove the HCS from the printer. (Refer to "Finisher Stapler" on page 35)
2. Remove the Harness Cover. (Refer to "Harness Cover" on page 46)
3. Remove the Harness Guide Cover.
4. Release wires under the Harness Guide from the clip.
5. Pull out J255, J292, J294A, J295A and J296A.
6. Remove the screw securing top Harness Guide and remove the Harness Guide.
7. Remove two screws on the bottom of the Top Tray Assembly securing the Assembly to the HCS frame.
8. Loosen two screws on the top of the Top Tray Assembly securing the Assembly to the HCS frame.
9. Lift the Top Tray Assembly out of two screw holes and remove the Assembly from the HCS frame.

#### 3.4.35.2 Installation

1. Hang the Top Tray Assembly on the HCS frame as the two screws on the top of the HCS frame go under the screw holes of the Top Tray Assembly.
2. Fasten two screws.
3. Secure the bottom of the Assembly to the HCS frame with two screws.
4. Let the Top Tray Assembly wire harness through the slot at the bottom of the Harness Guide.
5. Install the top Harness Guide and secure it to the HCS frame with a screw.
6. Connect J255, J292A, J294A, J295A and J296A.
7. Install top Harness Cover. (Refer to "Harness Cover" on page 46)
8. Connect HCS to the printer. (Refer to "Finisher Stapler" on page 35)

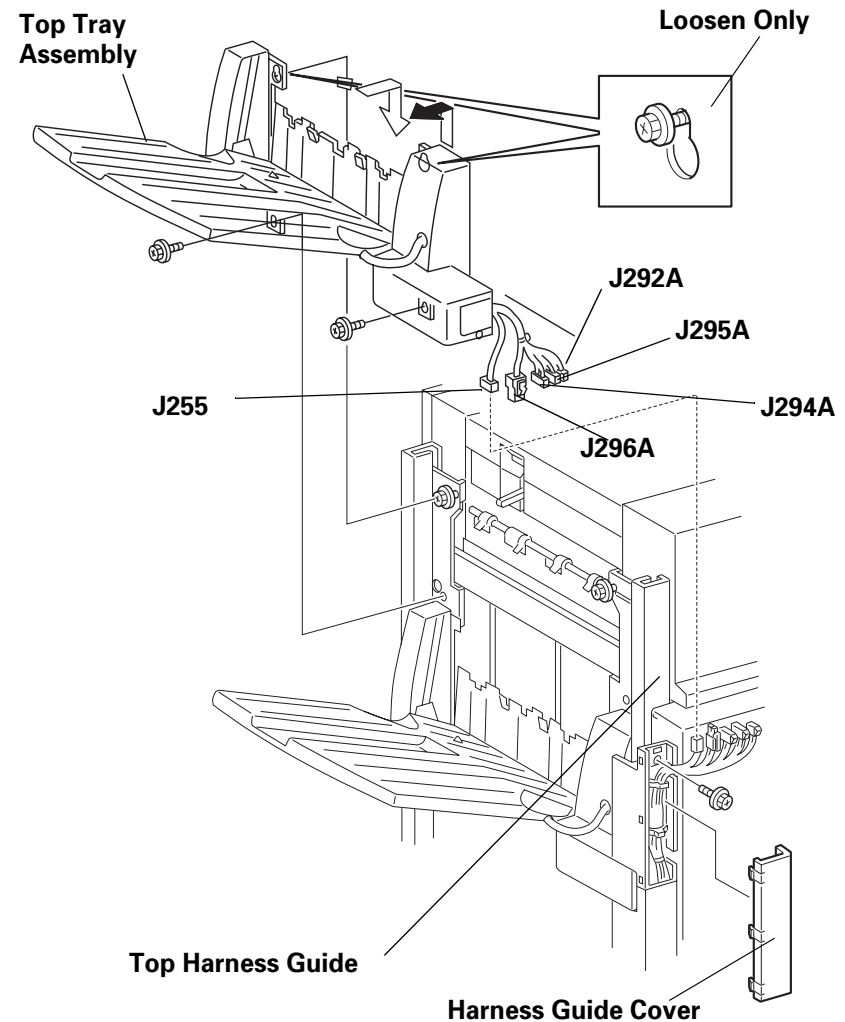

SER756XA

Figure 3-42. Top Tray Assembly

### 3.4.36 Top Tray Front Cover

Refer to the exploded diagram (Figure 4-33, "Top Tray" on page 179).

#### 3.4.36.1 Removal

1. Remove the Top Tray Assembly. (Refer to "Top Tray Assembly" on page 77)
2. Break open the Top Tray Front Cover and remove the cover.

#### 3.4.36.2 Installation

1. Install the Front Cover to the Top Tray.
2. Install Top Tray Assembly. (Refer to "Top Tray Assembly" on page 77)

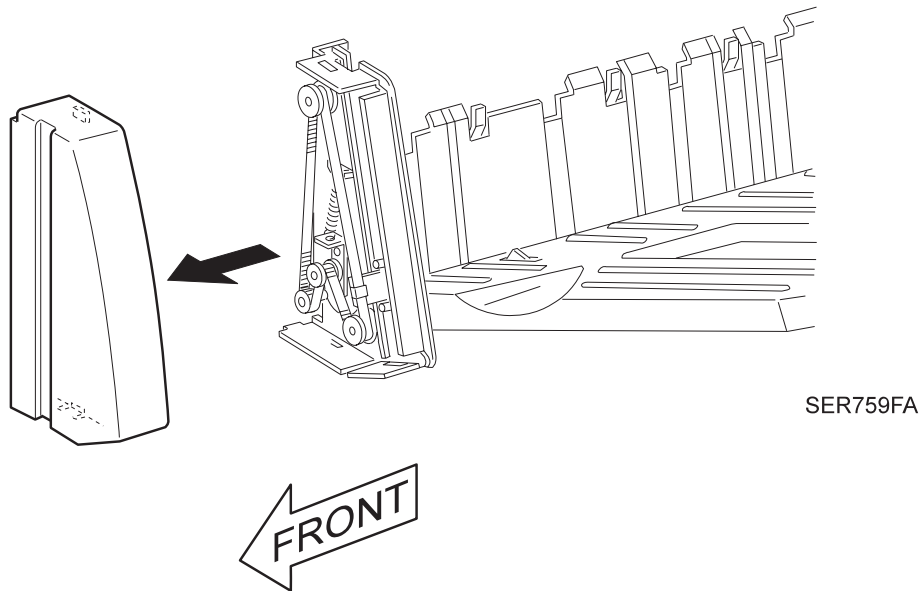

Figure 3-43. Top Tray Front Cover

### 3.4.37 Top Tray Half and Full Sensors

Refer to the exploded diagram (Figure 4-33, "Top Tray" on page 179).

#### 3.4.37.1 Removal

1. Remove the Top Tray Assembly. (Refer to "Top Tray Assembly" on page 77)
2. Slide off the Rear Harness Cover from the Top Tray Rear.
3. Remove the screw at the bottom of the Top Tray Rear Cover, securing the rear cover to the Tray frame.
4. Set the latches at the upper part of the Rear Cover off and remove the Cover.
5. Remove the screw securing Sensor Bracket to the Tray frame and remove the Bracket.
6. Pull out P251 from the Half Sensor.
7. Push the Sensor latches in and release, which connects the Sensor to the Bracket, and remove the Sensor.
8. Pull out P252 from Full Sensor.
9. Push the Sensor latches in and release, which connects the Sensor to the Bracket, and remove the Sensor.

#### 3.4.37.2 Installation

1. Place the Full Sensor as shown in the Figure 3-34 and insert it with latches ahead into the cutouts of the Sensor Bracket and set the latches on.
2. Connect P252 to the Full Sensor.
3. Place the Half Sensor as shown in the Figure 3-34 and insert Half Sensor with latches ahead to the cutouts of the Sensor Bracket and set the latches on.
4. Connect P251 to Full Sensor.
5. Install Sensor Bracket to the Tray frame and secure it to the frame with a screw.

6. First set the latches at the upper part of Rear Cover and then secure it to the Tray frame with a screw.
7. Let the wire harness through the cutout at the back of the Cover and slide the Rear Harness Cover into the Bottom Tray Rear Cover.
8. Install Top Tray Assembly. (Refer to "Top Tray Assembly" on page 77)

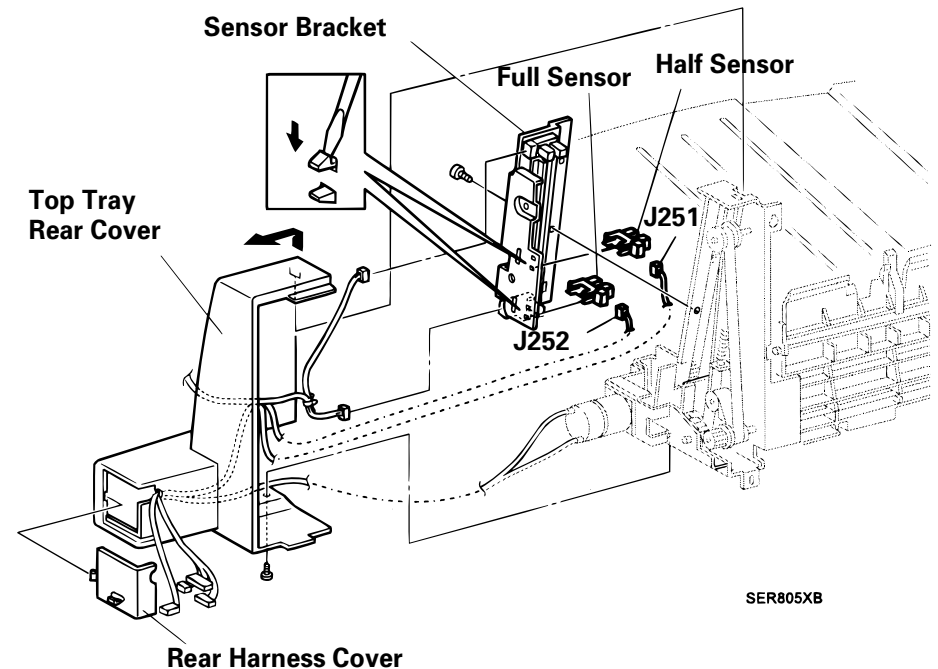

Figure 3-44. Top Tray Half and Full Sensors

### 3.4.38 Top Tray Lower and Upper Limit Sensor

Refer to the exploded diagram (Figure 4-33, "Top Tray" on page 179).

#### 3.4.38.1 Removal

1. Remove the Top Tray Assembly. (Refer to "Top Tray Assembly" on page 77)
2. Slide off Rear Harness Cover from Top Tray Rear Cover.
3. Remove the screw on the bottom of the Rear Cover securing Top Tray Rear Cover to the Tray frame.
4. Release the latches at the upper part of the Rear Cover and remove the Cover.
5. Remove screws securing Sensor Bracket to the Tray frame and remove the Sensor Bracket.
6. Pull out P253 from the Upper Limit Sensor.
7. Push the Sensor latches in and release, which connects the Sensor to the Bracket, and remove the Sensor.
8. Pull out P254 from Lower Limit Sensor.
9. Push the Sensor latches in and release, which connects the Sensor to the Bracket, and remove the Sensor.

#### 3.4.38.2 Installation

1. Place the Lower Limit Sensor as shown in the Figure 3-35 and insert it with latches ahead into the cutouts of the Sensor Bracket and set the latches on.
2. Connect P254 to the Lower Limit Sensor.
3. Place the Upper Limit Sensor as shown in the Figure 3-35 and insert it with latches ahead into the cutouts of the Sensor Bracket and set the latches on.
4. Connect P253 to Upper Sensor.
5. Install Sensor Bracket to the Tray frame and secure it to the frame with a screw.

6. First set the latches at the upper part of Rear Cover and then secure it to the Tray frame with a screw.
7. Let the wire harness through the cutout at the back of the Cover and slide the Rear Harness Cover into the Bottom Tray Rear Cover.
8. Install Top Tray Assembly. (Refer to "Top Tray Assembly" on page 77)

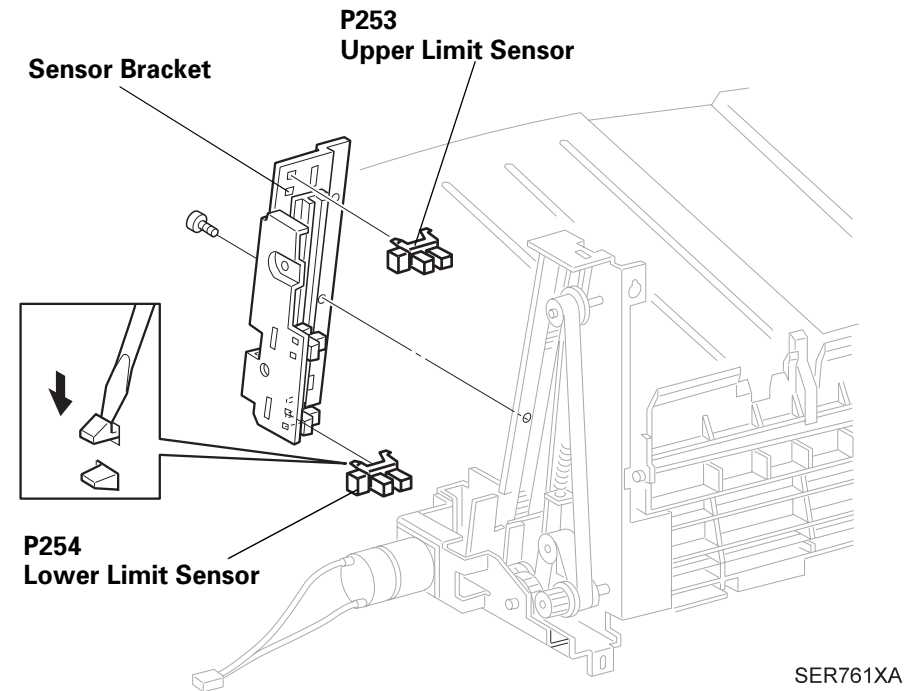

Figure 3-45. Top Tray Lower and Upper Limit Sensor



### 3.4.39 Top Tray

Refer to the exploded diagram (Figure 4-33, "Top Tray" on page 179).

#### 3.4.39.1 Removal

1. Remove Top Tray Assembly. (Refer to "Top Tray Assembly" on page 77)
2. Remove Top Tray Drive Belts. (Refer to "Top Tray Drive Belts" on page 84)
3. Remove Top Tray Paper Sensor. (Refer to "Middle Tray Paper Sensor" on page 72)
4. Remove screw securing Sensor wire harness to the bottom of the Tray and remove the harness.
5. Remove the Tray by sliding it off from the grooves of the Front Tray frame and the Rear Tray frame. (Figure 1)
6. Remove four screws securing the Carriage to the Tray and remove the Tray. (Figure 2)

#### 3.4.39.2 Installation

1. Install the Carriage to the Tray and secure it with four screws.
2. Install the Tray into the grooves of Front Tray Frame and Rear Tray Frame.
3. Install Sensor wire harness to the bottom of the Tray and secure it with screw.
4. Install Top Tray Paper Sensor. (Refer to "Middle Tray Paper Sensor" on page 72)
5. Install Top Tray Drive Belts. (Refer to "Top Tray Drive Belts" on page 84) to the both sides of the frame.
6. Install Top Tray Assembly. (Refer to "Top Tray Assembly" on page 77)

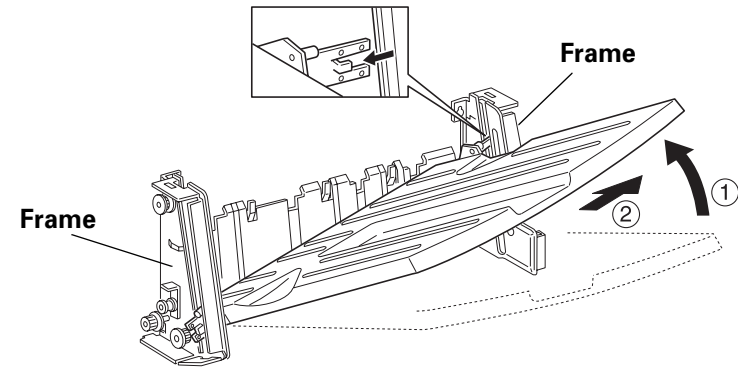

Figure 1

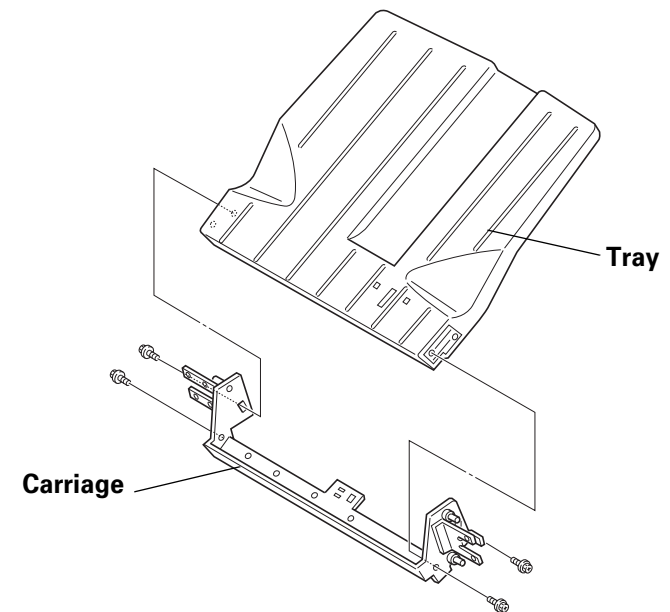

Figure 2

SER765XB

Figure 3-46. Top Tray

### 3.4.40 Top Tray Paper Sensor

Refer to the exploded diagram (Figure 4-33, "Top Tray" on page 179).

#### 3.4.40.1 Removal

1. Remove Top Tray Assembly. (Refer to "Top Tray Assembly" on page 77)
2. Remove three screws securing Back Cover to the Tray and remove the Cover.
3. Remove a screw securing Paper Sensor Bracket to the Tray and remove the Sensor Bracket along with Paper Sensor.
4. Pull out J250 from the Sensor.
5. Push the Sensor latches in and release, which connects the sensor to the bracket, and remove the sensor.

#### 3.4.40.2 Installation

1. Place the Top Tray Paper Sensor as shown in the Figure 3-47 and insert it with the latches ahead into the cutouts of the Sensor Bracket and set the latches on.
2. Connect J250 to the Sensor.
3. Ensure position-marking tabs on the Tray comes into the holes of the Bracket and install the Sensor Bracket to the Tray.
4. Secure the Bracket to the Tray with a screw.
5. Install the Back Cover to the Tray and secure it with three screws.
6. Install Top Tray Assembly. (Refer to "Top Tray Assembly" on page 77)

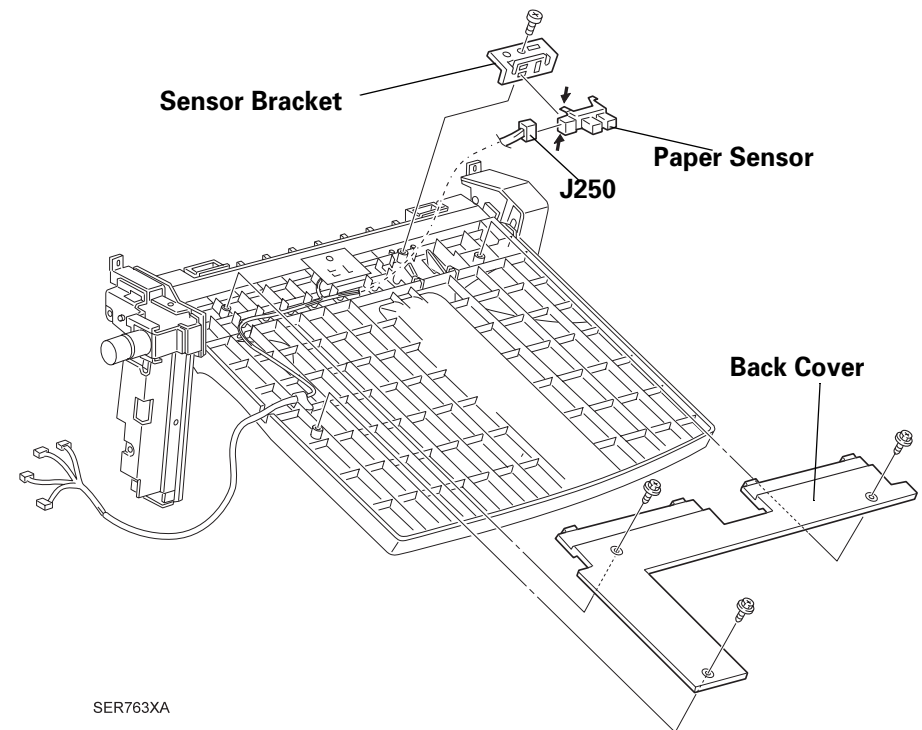

**Figure 3-47. Top Tray Paper Sensor**

### 3.4.41 Top Tray Motor

Refer to the exploded diagram (Figure 4-33, "Top Tray" on page 179).

#### 3.4.41.1 Removal

1. Remove the Top Tray Assembly. (Refer to "Top Tray Assembly" on page 77)
2. Remove Rear Harness Cover from the Top Tray Rear Cover by sliding it off.
3. Remove the screw at the bottom of the Rear Cover securing Top Tray Rear Cover to the Tray Frame.
4. Release the latches at the upper part of the Rear Cover and remove the Cover.
5. Remove four screws securing the Motor Bracket to the Tray and remove the Bracket along with the Motor.
6. Remove the E ring binding Gear to the Motor shaft and remove the Shaft Gear.
7. Remove two screws securing the Motor to the Bracket and remove the Motor.

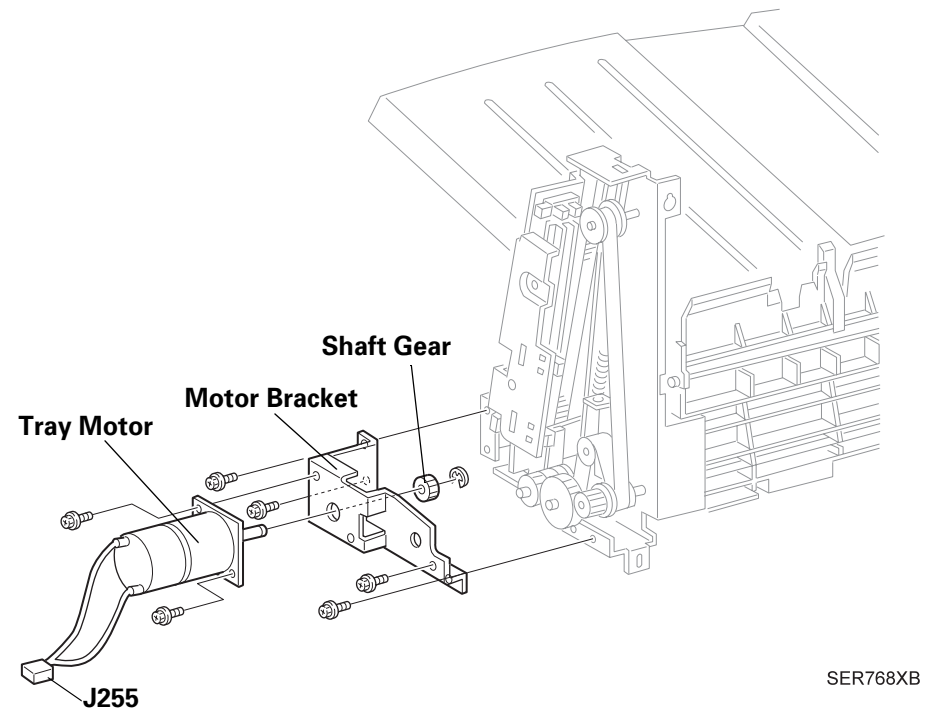

Figure 3-48. Top Tray Motor

#### 3.4.41.2 Installation

1. Install the Motor to the Motor Bracket and secure it with two screws.
2. Install the Gear to the end of Motor Shaft.
3. Secure the Gear to the Shaft with E ring.
4. Install the Bracket along with the Motor to the Tray frame and secure it with four screws.
5. Set the latches on the top of the Rear Cover and then secure it to the Tray frame with a screw.
6. Let the wire harness through the cutouts on the back of the Cover and install Rear Harness Cover by sliding.
7. Install Top Tray Assembly. (Refer to "Top Tray Assembly" on page 77)

### 3.4.42 Top Tray Drive Belts

Refer to the exploded diagram (Figure 4-34, "Top Tray Frame" on page 180).

#### 3.4.42.1 Removal

1. Remove the Top Tray Assembly. (Refer to "Top Tray Assembly" on page 77)
2. Remove the Top Tray Front Cover. (Refer to "Top Tray Front Cover" on page 78)
3. Remove the Tension Spring from the Tension Plate. (Figure 3-49)
4. Remove two screws securing Tension Plate to the Tray frame and remove the Plate.
5. Remove two screws securing Belt Clamp to the Tray and remove the Clamp.
6. Remove the Belt from the Clamp by sliding.
7. Remove the E ring binding the Drive Gear to the Shaft and remove the Gear.
8. Remove the Front Drive Gear.

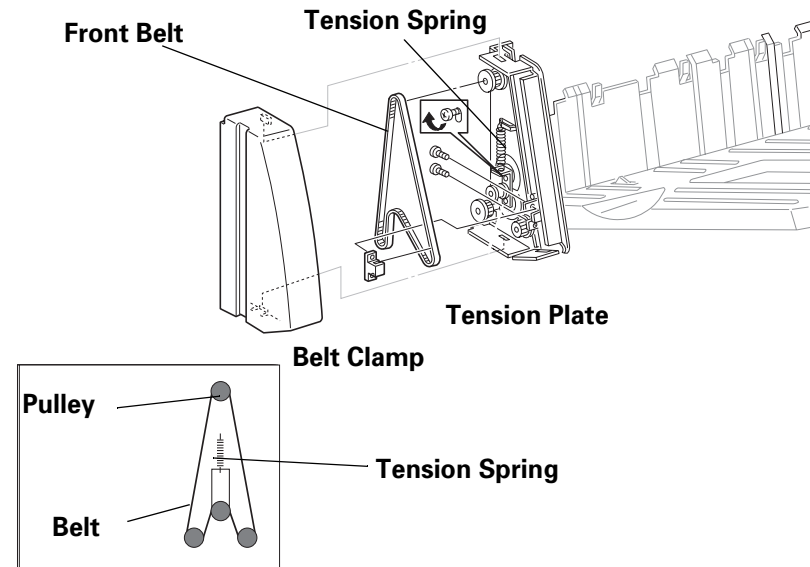

SER815XB1

**Figure 3-49. Front Drive Belt**

9. Remove the Top Tray Motor. (Refer to "Top Tray Motor" on page 83)
10. Remove the screw securing the Sensor Bracket to the Tray frame and remove the Bracket.
11. Remove the Tension Spring from the Tension Plate. (Figure 3-31)
12. Remove two screws securing the Limit Actuator to the Tray frame and remove the Actuator.
13. Remove two screws securing the Tension Plate to the Tray frame and remove the Tension Plate.
14. Remove two screws securing the Belt Clamp to the Tray frame and remove the Belt Clamp.
15. Remove the Belt from the Clamp by sliding.
16. Remove the E ring binding the Drive Gear to the shaft and remove the Drive Gear.
17. Remove the Rear Drive Belt.

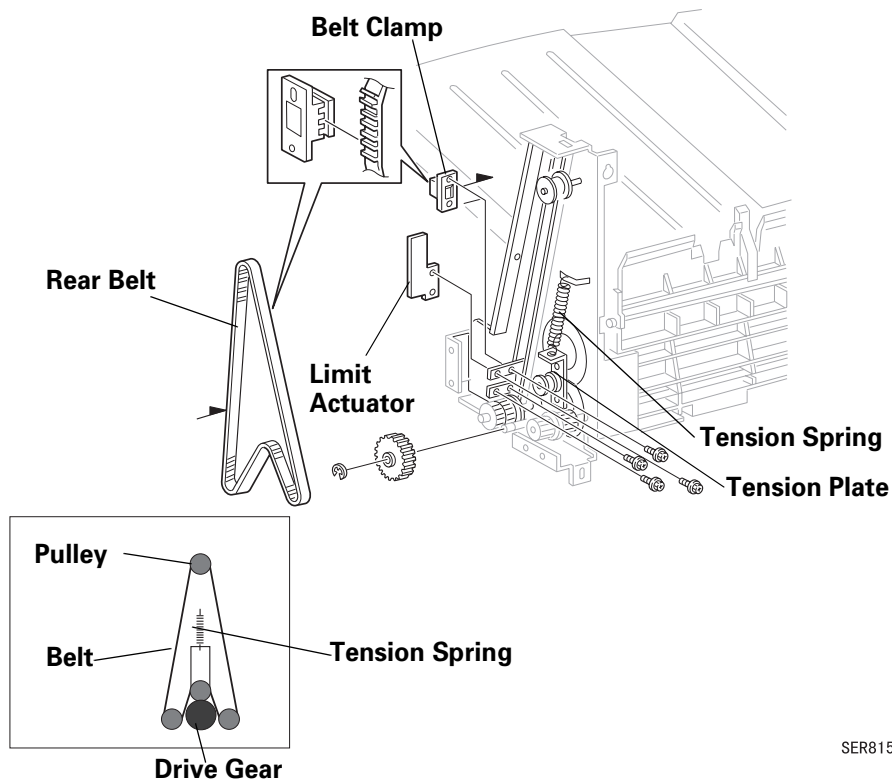

SER815XB2

Figure 3-50. Rear Drive Belt

### 3.4.42.2 Installation

1. Install the Rear Drive Belt as shown in the Figure 3-50.
2. Install the Drive Gear to the shaft and secure it with E ring.
3. Slide the Rear Belt around the Clamp.
4. Secure the Clamp to the Tray frame with two screws.
5. Install the Tension Plate to the frame and secure it with two screws.
6. Install the Limit Actuator to the frame and secure it with two screws.
7. Hang the Tension Spring on the Tension Plate.
8. Install the Sensor Bracket to the Tray frame and secure it with a screw.

9. Install the Top Tray Motor. (Refer to "Top Tray Motor" on page 83)
10. Install the Front Drive Belt as shown in the Figure 3-49.
11. Install the Rear Belt to the Clamp by sliding.
12. Secure the Clamp to the Tray frame with two screws.
13. Install the Tension Plate to the frame and secure it with two screws.
14. Hang the Tension Spring to the Tension Plate.
15. Install the Top Tray Front Cover. (Refer to "Top Tray Front Cover" on page 78)
16. Install Top Tray Assembly. (Refer to "Top Tray Assembly" on page 77)

### 3.4.43 Top Tray Safety Switch

Refer to the exploded diagram (Figure 4-34, "Top Tray Frame" on page 180).

#### 3.4.43.1 Removal

1. Remove the Top Tray Front Cover. (Refer to "Top Tray Front Cover" on page 78)
2. Pull out J852 from the Safety Switch.
3. Remove two screws securing the Switch to the Tray frame and remove the switch.

#### 3.4.43.2 Installation

1. Install the Top Tray Safety Switch to the Middle Tray Front Cover.
2. Ensure Switch Actuator is under the resinous Link.
3. Secure the Switch to the Tray frame with two screws.
4. Connect J852 to the Safety Switch.
5. Install Top Tray Front Cover. (Refer to "Top Tray Front Cover" on page 78)

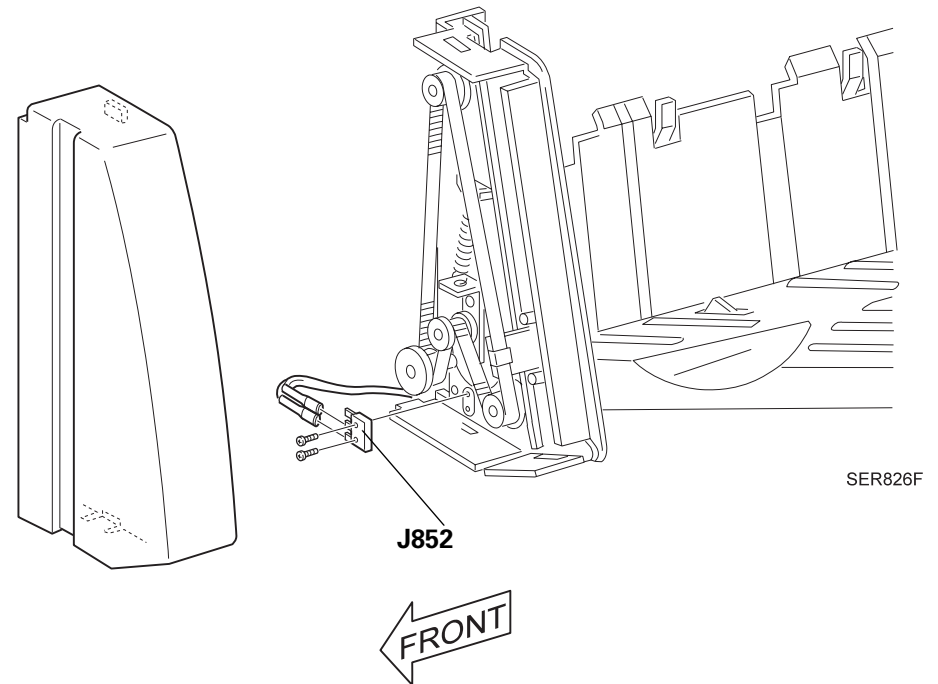

Figure 3-51. Top Tray Front Cover

### 3.4.44 Tamper Motor

Refer to the exploded diagram (Figure 4-35, "Tray Eject" on page 182).

#### 3.4.44.1 Removal

1. Lower the Stacker Elevator as the Bottom Tray comes to the bottom.
2. Remove the HCS. (Refer to "Finisher Stapler" on page 35)
3. Remove the L/H Cover. (Refer to "L/H Cover" on page 43)
4. Remove four screws securing the Tie Plate to the HCS frame and remove the Tie Plate  
(For Tie Plate, refer to Figure 4-36, "Exit" on page 183)
5. Remove the Top Tray. (Refer to "Top Tray Assembly" on page 77)
6. Remove four screws securing the Eject Roll Chute (PL19.1.24) to the HCS frame and remove the Chute.

**NOTE:** The Eject Roll Chute is at the back of the Top Tray.

7. From the rear of the Tamper Motor, remove two screws securing the Motor to the Compiler Tray.
8. Push the Tamper Motor Drive Belt away from the Motor Pulley and remove the Motor.
9. Pull out J867.

#### 3.4.44.2 Installation

1. Connect J867.
2. Install the Tamper Motor to the Compiler Tray.
3. Install the Tamper Motor Drive Belt to the Motor Pulley.
4. Determine the Motor position as the Motor is secured to the Compiler Tray and Motor Pulley does not rub against the Tray.
5. Secure the Motor to the Compiler with two screws.
6. Secure the Eject Roll Chute to the HCS frame with four screws.
7. Install the Top Tray. (Refer to "Top Tray Assembly" on page 77)

8. Install the Tie Plate to the HCS frame and secure it with four screws.
9. Install the L/H Cover. (Refer to "L/H Cover" on page 43)
10. Connect the HCS to the printer. (Refer to "Finisher Stapler" on page 35)

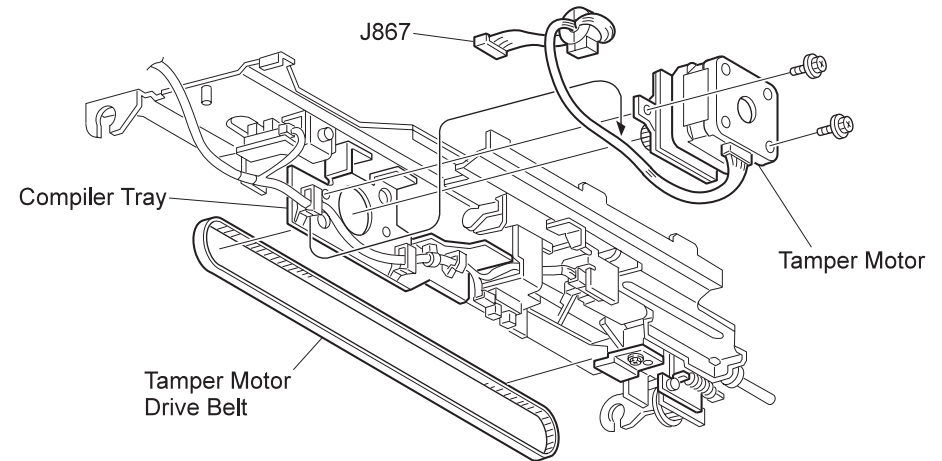

SR1561XA

**Figure 3-52. Tamper Motor**

### 3.4.45 Tamper Home Sensor

Refer to the exploded diagram (Figure 4-35, "Tray Eject" on page 182).

#### 3.4.45.1 Removal

1. Remove the HCS. (Refer to "Finisher Stapler" on page 35)
2. Remove the L/H Cover. (Refer to "L/H Cover" on page 43)
3. Remove four screws securing the Tie Plate to the HCS frame and remove the Tie Plate.  
(For Tie Plate, refer to Figure 4-36, "Exit" on page 183)
4. Remove the screw securing the Tamper Home Sensor Bracket to the Compiler Tray and remove the Bracket along with the Tamper Home Sensor.
5. Pull out P839 from the Sensor.
6. Push in the Sensor latches and set it off, which securing the Sensor to the Bracket, and remove the Sensor.

#### 3.4.45.2 Installation

1. Place the Tamper Home Sensor as shown in the Figure 3-53 and insert the Sensor with the latches ahead into the cutout of the Sensor Bracket and set the latches.
2. Connect P839 to the Sensor.
3. Install the Tamper Home Sensor Bracket to the Compiler Tray and secure the Bracket with a screw.
4. Install the Tie Plate to the HCS frame and secure it with four screws.
5. Install the L/H Cover. (Refer to "L/H Cover" on page 43)
6. Connect the HCS to the printer. (Refer to "Finisher Stapler" on page 35)

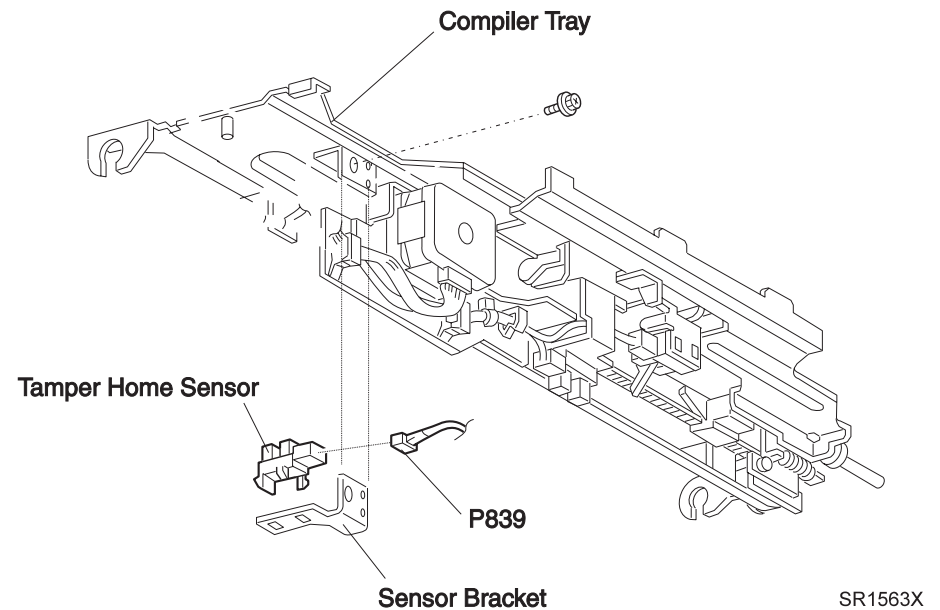

Figure 3-53. Tamper Home Sensor



### 3.4.46 Compiler Paper Sensor

Refer to the exploded diagram (Figure 4-35, "Tray Eject" on page 182).

#### 3.4.46.1 Removal

1. Remove the HCS. (Refer to "Finisher Stapler" on page 35)
2. Remove the L/H Cover. (Refer to "L/H Cover" on page 43)
3. Remove four screws securing the Tie Plate to the HCS frame and remove the Tie Plate.  
(For Tie Plate, refer to Figure 4-36, "Exit" on page 183)
4. Remove the screw securing the Compiler Paper Sensor Bracket to the Compiler Tray and remove the Bracket along with the Compiler Paper Sensor.
5. Pull out P843 from the Sensor.
6. Push in the Sensor latches and set it off, which securing the Sensor to the Bracket, and remove the Sensor.

#### 3.4.46.2 Installation

1. Place the Compiler Paper Sensor as shown in the Figure 3-54 and insert the Sensor with the latches ahead into the cutout of the Sensor Bracket and set the latches.
2. Connect P843 to the Sensor.
3. Install the Compiler Paper Sensor Bracket to the Compiler Tray and secure the Bracket with a screw.
4. Install the Tie Plate to the HCS frame and secure it with four screws.
5. Install the L/H Cover. (Refer to "L/H Cover" on page 43)
6. Connect the HCS to the printer. (Refer to "Finisher Stapler" on page 35)

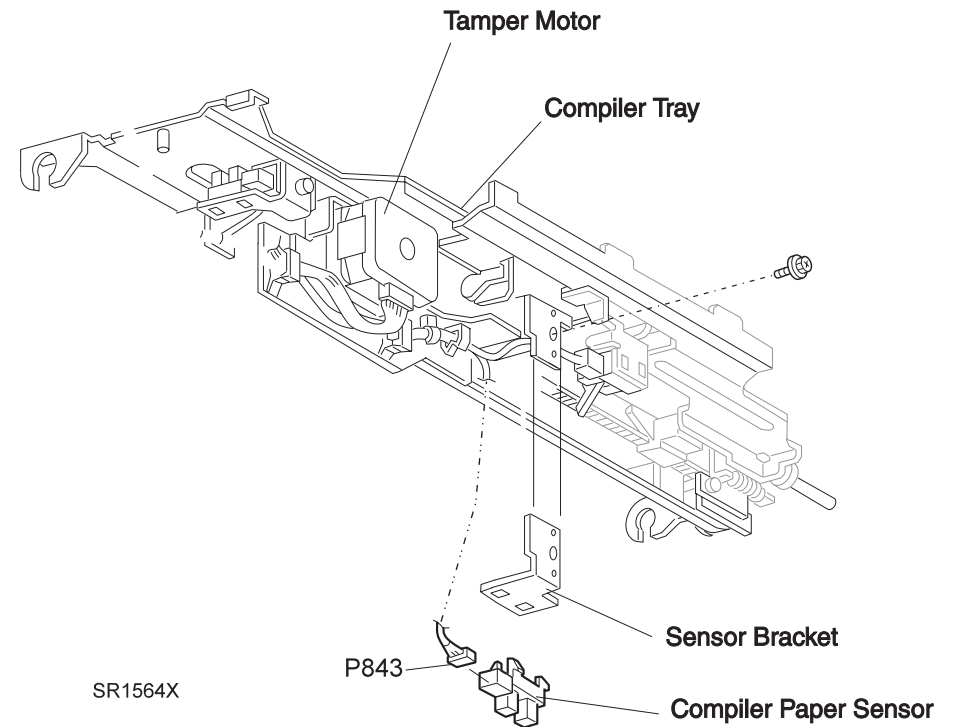

**Figure 3-54. Compiler Paper Sensor**

### 3.4.47 End Wall Open Sensor

Refer to the exploded diagram (Figure 4-35, "Tray Eject" on page 182).

#### 3.4.47.1 Removal

1. Remove the HCS. (Refer to "Finisher Stapler" on page 35)
2. Remove the L/H Cover. (Refer to "L/H Cover" on page 43)
3. Remove four screws securing the Tie Plate to the HCS frame and remove the Tie Plate.  
(For Tie Plate, refer to Figure 4-36, "Exit" on page 183)
4. Push in the Sensor latches and set it off, which securing the Sensor to the Bracket, and remove the Sensor.
5. Pull out P840 from the Sensor.

#### 3.4.47.2 Installation

1. Connect P840 to the Sensor.
2. Place the End Wall Open Sensor as shown in the Figure 3-55 and insert the Sensor with the latches ahead into the cutout of the Sensor Bracket and set the latches.
3. Install the Tie Plate to the HCS frame and secure it with four screws.
4. Install the L/H Cover. (Refer to "L/H Cover" on page 43)
5. Connect the HCS to the printer. (Refer to "Finisher Stapler" on page 35)

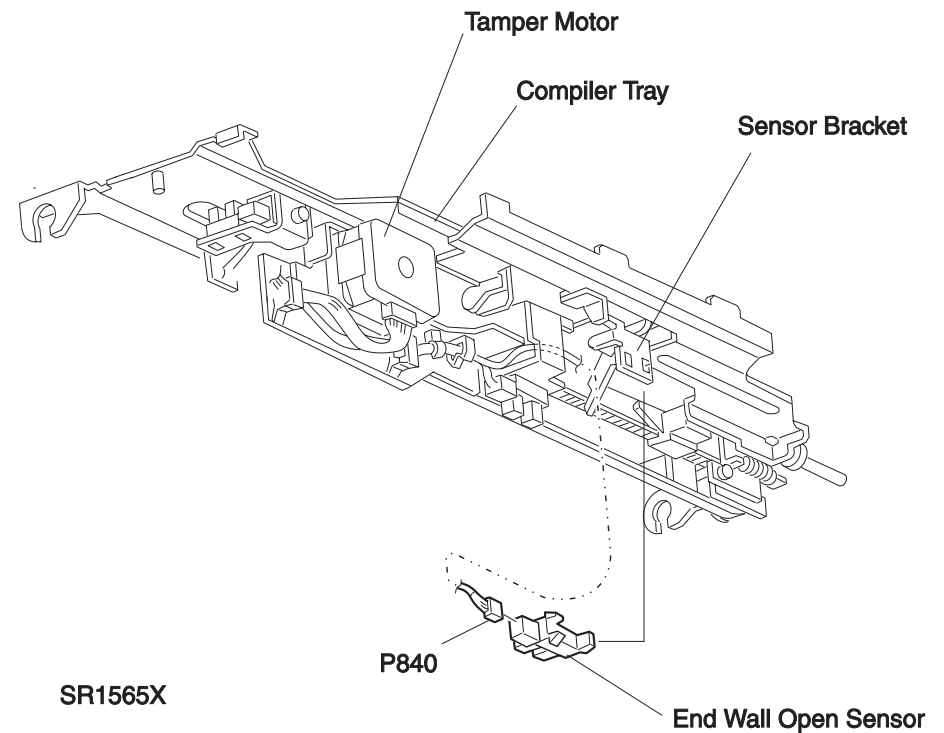

**Figure 3-55. End Wall Open Sensor**

### 3.4.48 Tamper Motor Drive Belt

Refer to the exploded diagram (Figure 4-35, "Tray Eject" on page 182).

#### 3.4.48.1 Removal

1. Remove the Tamper Motor. (Refer to "Tamper Motor" on page 87)
2. Loosen the screw for the Belt Holder and remove the Belt from the Holder by sliding it off.
3. Remove the Belt from the Tension Pulley by sliding it off.

#### 3.4.48.2 Installation

1. Place the Tamper Motor Drive Belt as the ribs come inside the Belt loop.
2. Install the Belt to the Tension Pulley by sliding it.
3. Insert the Belt between the top and bottom of the Belt Holder and fasten the screw for the Belt Holder.
4. Install the Tamper Motor. (Follow the installing process of the Tamper Motor to step 6.)
5. Fasten the Belt Tension Screw enough as the Belt does not come off when the Tamper Motor is running.
6. Install the Tie Plate to the HCS frame and secure it with four screws.
7. Install the L/H Cover. (Refer to "L/H Cover" on page 43)
8. Connect the HCS to the printer. (Refer to "Finisher Stapler" on page 35)

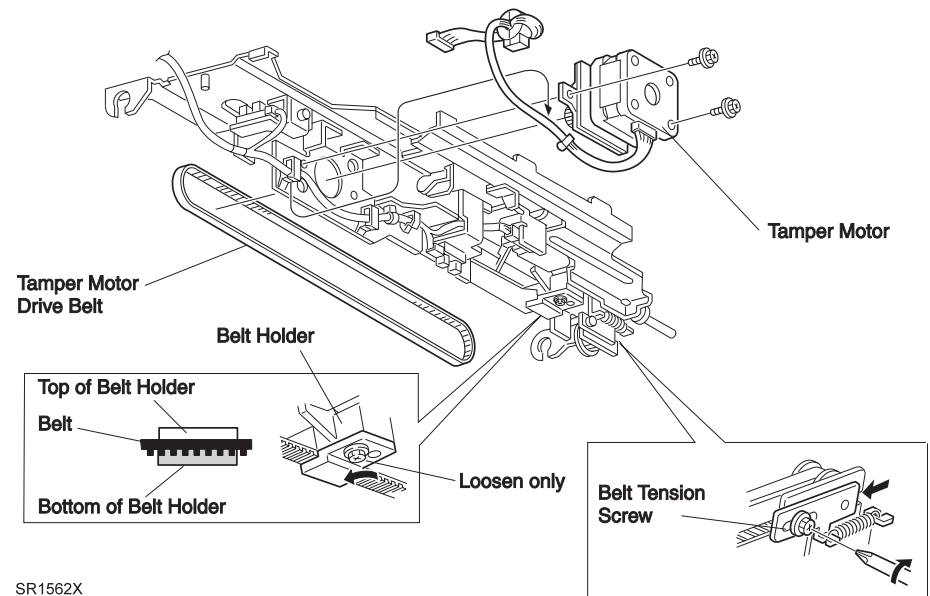

SR1562X

Figure 3-56. Tamper Motor Drive Belt

### 3.4.49 Compiler Tray Solenoid Assembly

Refer to the exploded diagram (Figure 4-35, "Tray Eject" on page 182).

#### 3.4.49.1 Removal

1. Remove the End Wall Motor. (Refer to "End Wall Motor" on page 112)
2. Remove the K Clip binding the End Wall Link to the End Wall Shaft and remove the Link from the shaft by sliding it off.
3. Remove two screws holding the Compiler Tray Solenoid to the HCS frame.
4. Remove the Solenoid Link from the End Wall Shaft by sliding it off.
5. Pull out P869.

#### 3.4.49.2 Installation

1. Connect P869.
2. Slide in the Solenoid Link to the End Wall Shaft and install the Compiler Tray Solenoid to the HCS frame.
3. Secure the Solenoid to the frame with two screws.
4. Slide in the End Wall Link to the End Wall Shaft and secure the Link to the Shaft with K clip.
5. Install the End Wall Motor. (Refer to "End Wall Motor" on page 112)

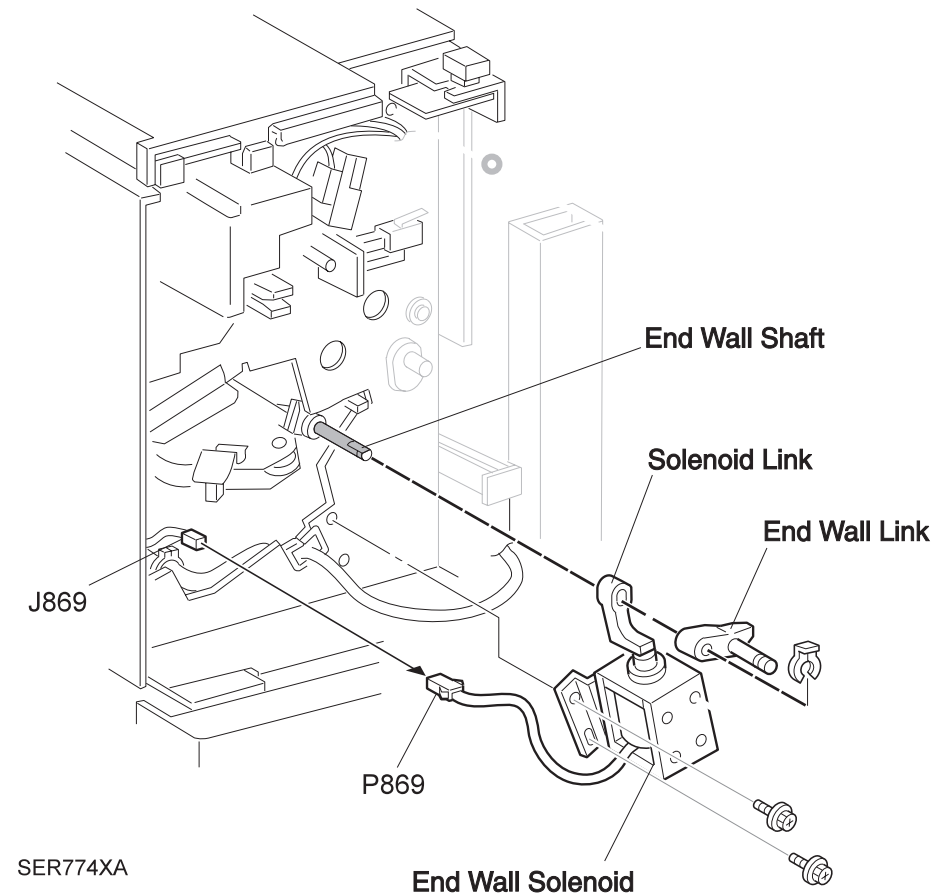

Figure 3-57. Compiler Tray Solenoid Assembly

### 3.4.50 Eject Shaft Assemblies

Refer to the exploded diagram (Figure 4-35, "Tray Eject" on page 182).

#### 3.4.50.1 Removal

1. Remove the Eject Cover. (Refer to "Eject Cover" on page 45)
2. Remove the Top Tray Assembly. (Refer to "Top Tray Assembly" on page 77)
3. Remove four screws securing the Ejector Roll Chute to the HCS frame and remove the Chute.
4. Remove the Set Clamp Motor. (Refer to "Set Clamp Motor" on page 115)
5. Remove E ring binding the Set Clamp Actuator to the Shaft 1 and remove the Actuator and Pulley and metal bearing.
6. Remove E ring binding front metal bearing to the Shaft 1 and remove the front bearing.
7. Remove E ring binding Offset Lever to the Shaft 2 and remove the Offset Lever.
8. Remove E ring binding the Eject Gear to the Shaft 2 and remove the Eject Gear.
9. Remove the screw securing the rear plastic bearing to the Shaft 2 and remove the rear bearing from the Shaft.
10. Remove two screws securing the front plastic bearing to the Shaft 2 and remove the front bearing from the shaft.
11. Remove the Shaft 1 and the Shaft 2 (the Eject Shaft Assemblies) as one unit.

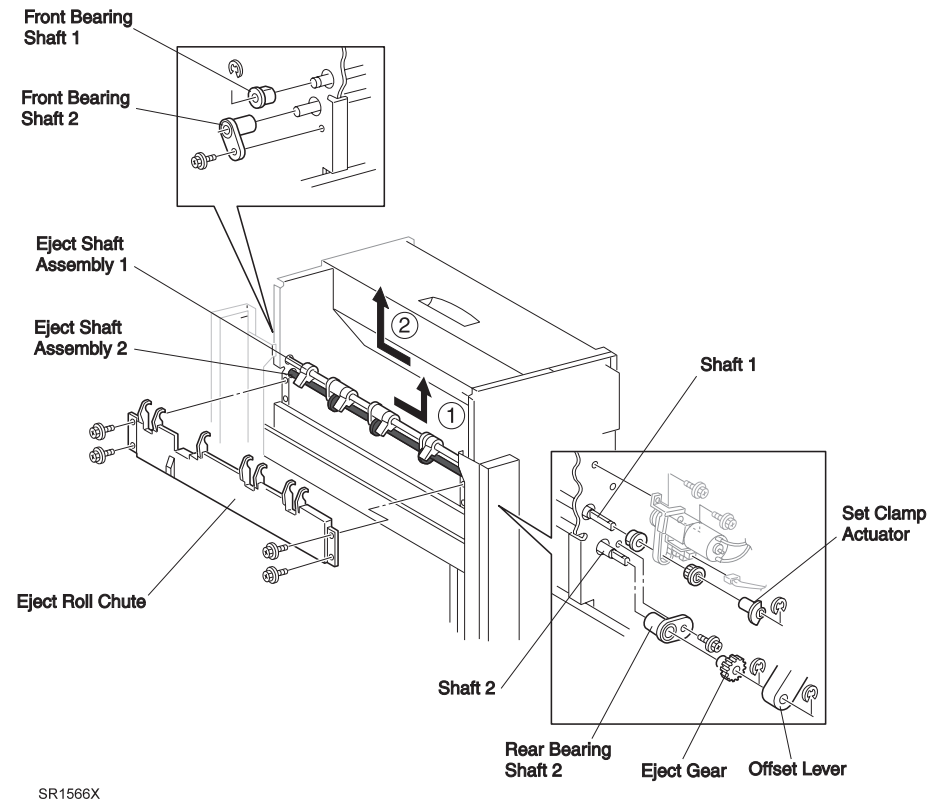

**Figure 3-58. Eject Shaft Assemblies**

#### 3.4.50.2 Installation

1. Place the Eject Shaft Assemblies as shown in the Figure 3-58 and install them to the HCS frame.
2. Install the front metal bearing and rear metal bearing by sliding them from the both ends of the Shaft 1.
3. Place the Tray as the front and rear arms of the Compiler Tray parallels with the Shaft 1.
4. Slide the front metal bearing and the rear metal bearing into the cutouts of the HCS frame and slide them on the arms of Compiler Tray.

5. Install the front metal bearing to the front end of the Shaft 1 with E ring.
6. Slide the Pulley and the Set Clamp Actuator to the rear end of the Shaft 1 and secure them to the Shaft with E ring.
7. Slide the front plastic bearing to the front end of the Shaft 2 and secure the bearing with a screw.
8. Slide the rear plastic bearing to the rear end of the Shaft 2 and secure it with a screw.
9. Slide the Eject Gear to the rear end of the Shaft 2 and secure it to the Shaft with E ring.
10. Slide the Offset Lever to the rear end of the Shaft 2 and secure it to the Shaft with E ring.
11. Install the Set Clamp Motor.(Refer to "Set Clamp Motor" on page 115)
12. Install the Eject Roll Chute to the HCS and secure the Chute with four screws.
13. Install the Top Tray Assembly. (Refer to "Top Tray Assembly" on page 77)
14. Install the Eject Cover. (Refer to "Eject Cover" on page 45)

### 3.4.51 Upper Exit Chute Assembly

Refer to the exploded diagram (Figure 4-36, "Exit" on page 183).

#### 3.4.51.1 Removal

1. Remove the Eject Pinch Roll Shaft Assembly. (Refer to "Eject Pinch Roll Shaft Assembly" on page 100)
2. Remove the screw securing the Finisher Stapler Interlock Switch Bracket to the front of the HCS frame and remove the Bracket to enable to remove the screw of the Upper Exit Chute Assembly.
3. Remove two screws securing the Upper Exit Chute Assembly to the front of the HCS frame.
4. Remove two screws securing the Upper Exit Chute Assembly to the back of the HCS frame.
5. Remove the Upper Exit Chute Assembly from the HCS by revolving it.

#### 3.4.51.2 Installation

1. Install the Upper Exit Chute Assembly to the HCS frame.
2. Place four threaded holes of the Upper Exit Chute Assembly to those of the HCS frame.
3. Secure the front side of the Upper Exit Chute Assembly to the HCS frame with two screws.
4. Secure the rear side of the Upper Exit Chute Assembly to the HCS frame with two screws.
5. Install the Finisher Stapler Interlock Switch Bracket to the front of the HCS frame and secure the Bracket with a screw.
6. Install the Eject Pinch Roll Shaft Assembly. (Refer to "Eject Pinch Roll Shaft Assembly" on page 100)

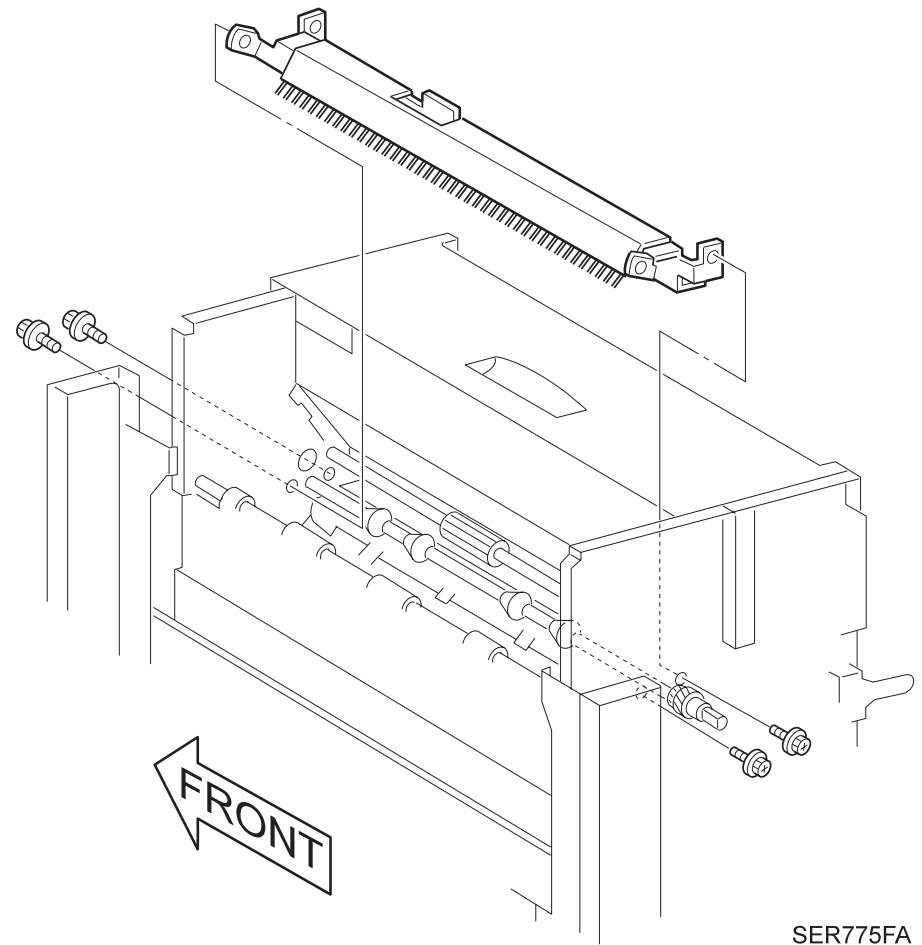

SER775FA

**Figure 3-59. Upper Exit Chute Assembly**

### 3.4.52 Exit Shaft Assembly

Refer to the exploded diagram (Figure 4-36, "Exit" on page 183).

#### 3.4.52.1 Removal

1. Remove the Upper Exit Chute Assembly. (Refer to "Upper Exit Chute Assembly" on page 95)
2. Remove the E ring binding the Paddle Shaft Drive Gear, which is right under the Exit Shaft Drive Pulley, to the shaft and remove the Drive Gear.
3. Remove the screw securing the Exit Shaft Pulley to the shaft and remove the pulley.
4. Remove two E rings binding the Front Exit Shaft bearing and the Rear Exit Shaft bearing to the shaft, and remove two bearings.
5. Remove the Exit Shaft Assembly from the HCS frame by sliding it off.

#### 3.4.52.2 Installation

1. Install the Exit Shaft Assembly to the HCS frame by inserting the front bearing and the rear bearing into the cutouts of the HCS frame.
2. Slide in the rear end of the Exit Shaft to the rear bearing.

**NOTE:** Leave space for the front end of the Exit Shaft to be slid into the front bearing.

3. Install the E ring to the both ends of the Shaft, for installing the shaft to the bearings.
4. Secure the Exit Shaft Pulley to the Exit Shaft and secure the Pulley to the Shaft.
5. Install the Paddle Shaft Drive Gear right under the Exit Shaft Pulley and secure the Gear to the Shaft with E ring.
6. Install the Upper Exit Chute Assembly. (Refer to "Upper Exit Chute Assembly" on page 95)

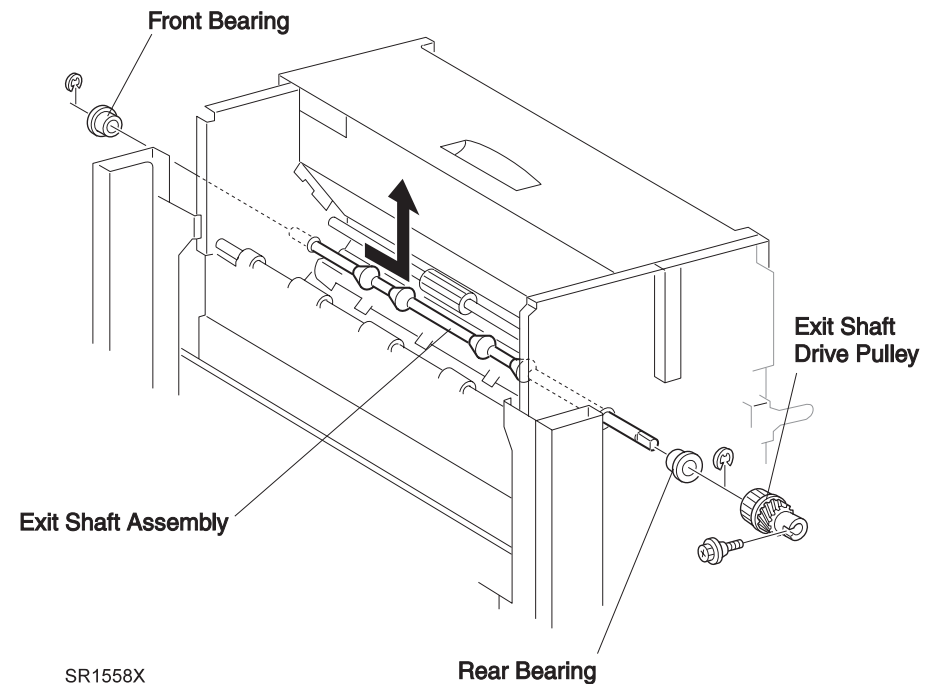

**Figure 3-60. Exit Shaft Assembly**



### 3.4.53 Paddle Shaft Assembly

Refer to the exploded diagram (Figure 4-36, "Exit" on page 183).

#### 3.4.53.1 Removal

1. Remove the Exit Shaft Assembly. (Refer to "Exit Shaft Assembly" on page 96)
2. Remove the E ring binding the gear to the Paddle Drive Shaft and remove the gear from the shaft. (Figure 3-61)
3. Remove the E ring binding the rear bearing to the Paddle Drive Shaft and remove the bearing from the Shaft.

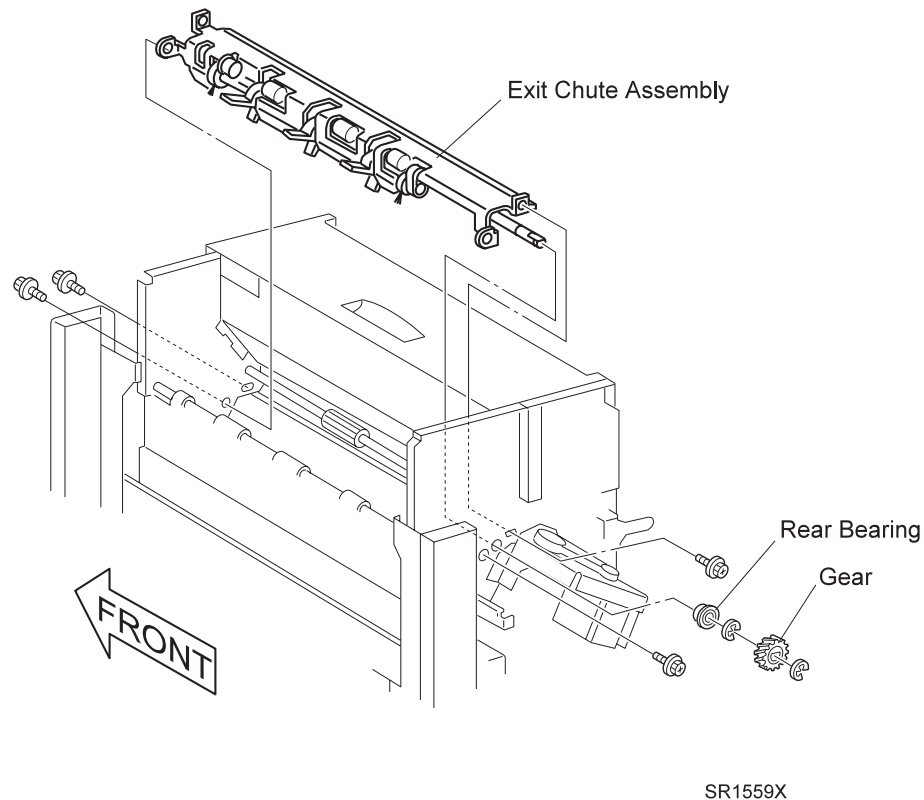

**Figure 3-61. Paddle Shaft Assembly**

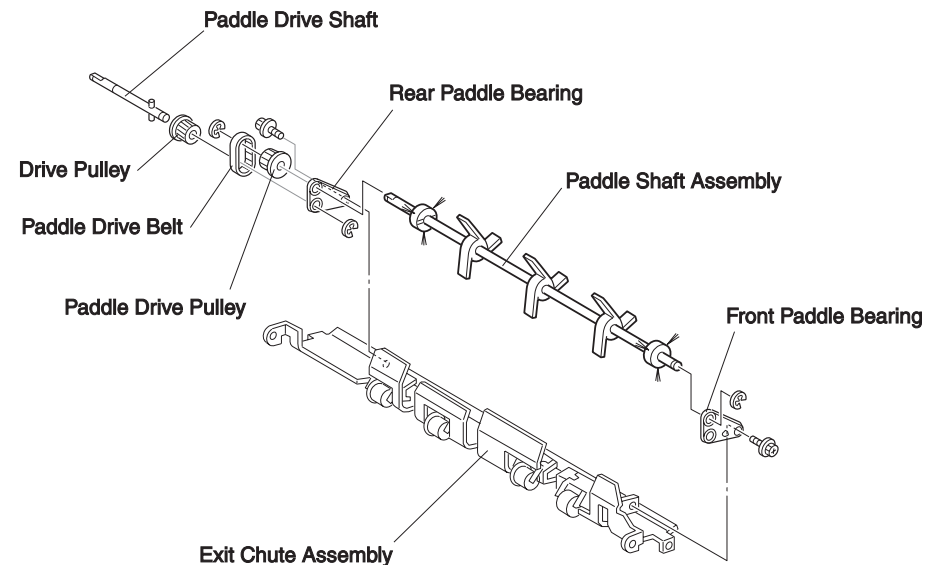

**Figure 3-62. Paddle Shaft Assembly**

4. Remove two screws securing the Exit Chute Assembly to the rear of the HCS frame.
5. Remove two screws securing the Exit Chute Assembly to the front of the HCS frame.
6. Remove Exit Chute Assembly.
7. Remove E rings from the both ends of the Paddle Shaft. (Figure 3-62)
8. Remove the Paddle Drive Belt from the Paddle Drive Pulley by sliding it off.
9. Remove the Paddle Drive Pulley from the Paddle Shaft by sliding it off.
10. Remove the screw securing the front Paddle Bearing and slide the bearing off from the Shaft.
11. Remove the screw securing the rear Paddle Bearing, and remove the bearing, Drive Shaft, and Paddle Shaft from the Exit Chute Assembly.
12. Remove the Paddle Shaft from the Rear bearing by sliding it off.

### **3.4.53.2 Installation**

1. Install the Drive Belt to the Drive Pulley.
2. Slide and install the rear end of the Paddle Shaft to the rear bearing.
3. Install the Paddle Shaft Assembly.
4. Slide and install the Front Paddle Bearing to the front end of the Paddle Shaft.
5. Secure the rear bearing to the Exit Chute with a screw.
6. Secure the front bearing to the Exit Chute with a screw.
7. Slide and install the Paddle Drive Pulley to the rear end of the Paddle Shaft and secure it to the Shaft with E ring.
8. Slide and install the Drive Belt to the Paddle Drive Pulley.
9. Secure the front end of the Paddle Shaft to the front bearing with E ring.
10. Install the Exit Chute Assembly to the HCS frame.
11. Secure the Exit Chute Assembly to the front side of the HCS frame with two screws.
12. Secure the Exit Chute Assembly to the rear side of the HCS frame with two screws.
13. Slide and install the metal bearing to the rear end of the Paddle Drive Shaft and secure it with E ring.
14. Slide and install the gear to the rear end of the Paddle Drive Shaft and secure it with E ring.
15. Install the Exit Shaft Assembly. (Refer to "Exit Shaft Assembly" on page 96)

### 3.4.54 Eject Chute Assembly

Refer to the exploded diagram (Figure 4-37, "Offset and Eject" on page 184).

#### 3.4.54.1 Removal

1. Remove the Eject Cover. (Refer to "Eject Cover" on page 45)
2. Remove the screw holding the Rear Pinch Roll Bearing and slide off the bearing to the rear.
3. Remove the screw holding the Front Pinch Roll Bearing and slide off the bearing to the front.
4. Remove the Eject Chute Assembly from the HCS frame.

#### 3.4.54.2 Installation

1. Place the Eject Chute Assembly as shown in the Figure 3-63, "Eject Chute Assembly" on page 99.
2. Install the Eject Chute Assembly.
3. Hang the two arms of the Eject Chute Assembly to the Pinch Roll Shaft.
4. Slide the front Pinch Roll Bearing to the rear as two arms of the Eject Chute Assembly comes on the Bearing.
5. Secure the Bearing to the HCS frame with a screw.
6. Slide the rear Pinch Roll Bearing to the front as two arms of the Eject Chute Assembly comes on the Bearing.
7. Secure the Bearing to the HCS frame with a screw.
8. Install the Eject Cover. (Refer to "Eject Cover" on page 45)

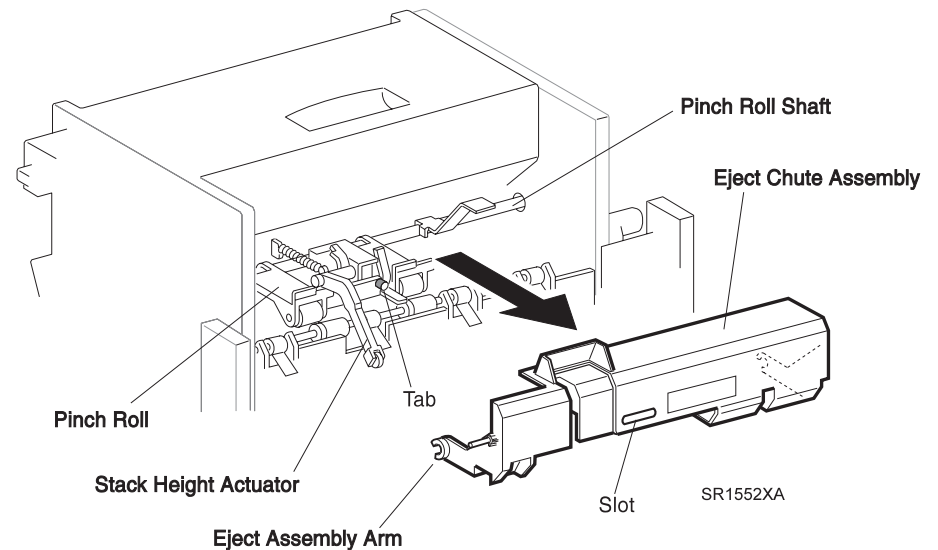

**Figure 3-63. Eject Chute Assembly**

### 3.4.55 Eject Pinch Roll Shaft Assembly

Refer to the exploded diagram (Figure 4-37, "Offset and Eject" on page 184).

#### 3.4.55.1 Removal

1. Remove the Eject Chute Assembly. (Refer to "Eject Chute Assembly" on page 99)
2. Pull out J832 from the Stack Height Sensor.
3. Remove E ring binding the Offset Lever to the rear of the Eject Pinch Roll Shaft.
4. Remove a screw holding the Lever to the Eject Pinch Roll Shaft.
5. Remove the front bearing.
6. Slide the Shaft to the front of the HCS and remove the Lever, Offset Lever, and bearing from the rear of the Shaft.
7. Slide off the Eject Pinch Roll Shaft Assembly to the rear and remove it from the HCS frame.

#### 3.4.55.2 Installation

1. Insert the rear of the Eject Pinch Roll Shaft Assembly to the bearing hole on the rear of the HCS.
2. Insert the front of the Eject Pinch Roll Shaft Assembly to the bearing hole on the front of the HCS.
3. Slide in the Rear bearing to the Shaft from the rear.
4. Slide in the Lever to the Shaft from the rear end and secure it with a screw.
5. Slide in the Offset Lever to the Shaft from the rear end and secure it with E ring.
6. Install the Front bearing to the Shaft from the front end.
7. Connect J832 to the Stack Height Sensor.
8. Install the Eject Chute Assembly. (Refer to "Eject Chute Assembly" on page 99)

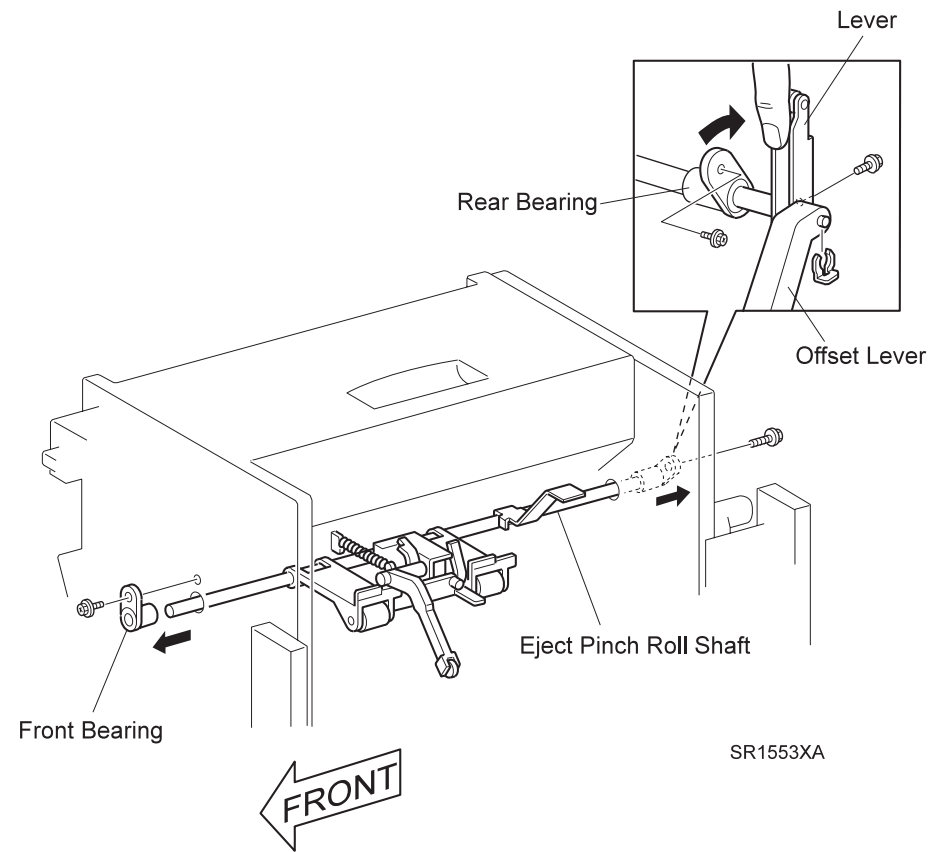

Figure 3-64. Eject Pinch Roll Shaft Assembly

### 3.4.56 Stack Height Sensor

Refer to the exploded diagram (Figure 4-37, "Offset and Eject" on page 184).

#### 3.4.56.1 Removal

1. Remove the Eject Pinch Roll Shaft Assembly. (Refer to "Eject Pinch Roll Shaft Assembly" on page 100)
2. Release the Latches, which holding the Stack Height Sensor to the Sensor Bracket, and remove the Sensor.

#### 3.4.56.2 Installation

1. Place the Stack Height Sensor as shown in the Figure 3-65 and insert it with the latches ahead to the cutout of the Sensor Bracket and install.
2. Move the Stack Height Sensor Actuator up and down and ensure the Actuator arm moves between the arms of the Stack Height Sensor freely.
3. Install the Eject Pinch Roll Shaft Assembly. (Refer to "Eject Pinch Roll Shaft Assembly" on page 100)

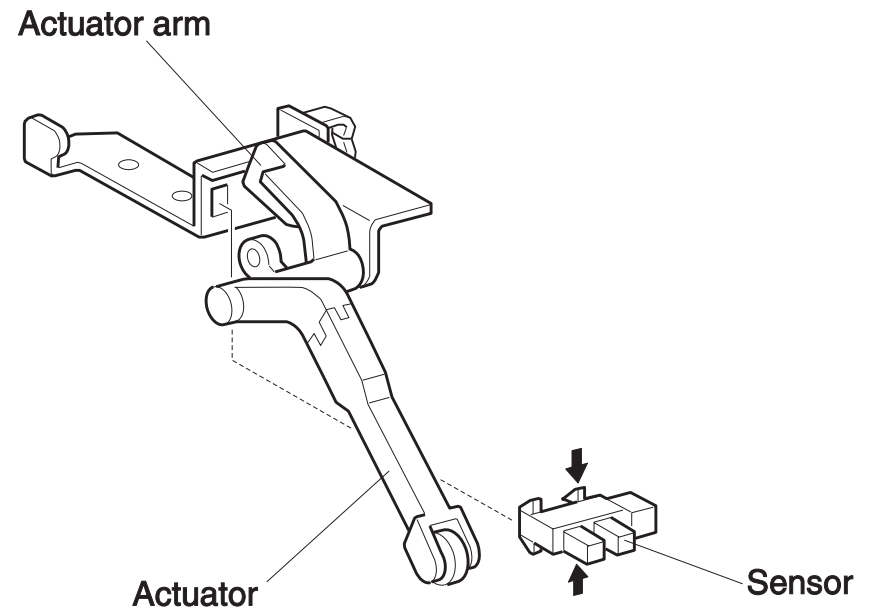

SR1554X

Figure 3-65. Stack Height Sensor

### 3.4.57 Paddle Drive Belt

Refer to the exploded diagram (Figure 4-37, "Offset and Eject" on page 184).

#### 3.4.57.1 Removal

1. Remove the Eject Pinch Roll Shaft Assembly. (Refer to "Eject Pinch Roll Shaft Assembly" on page 100)
2. Remove two screws holding the Front Pinch Roll Cover to the Eject Pinch Roll Shaft and slide off the Cover from the Shaft.
3. Remove the E ring holding the Paddle Cover Assembly to the Eject Pinch Roll Shaft and slide off the Cover Assembly from the Shaft.
4. Remove two screws holding the Sensor Bracket to the Paddle Cover Assembly and remove the Bracket.
5. Break open the Paddle from the Paddle Cover Assembly.
6. Remove the Paddle Drive Belt.

#### 3.4.57.2 Installation

1. Slide in the Paddle Drive Belt to the Paddle Gear.
2. Push in the Paddle to the Paddle Cover Assembly.
3. Install the Sensor Bracket Assembly to the Paddle Cover Assembly. Secure the Bracket with a screw.
4. Install the Drive Gear to the end of the Belt. Place the Gear to the center of the Paddle Cover Assembly.
5. Slide in the Paddle Cover Assembly to the Eject Pinch Roll Shaft.
6. Ensure the Drive Belt is placed as Shaft goes through the center of the Gear.
7. Secure the Paddle Cover Assembly to the Eject Pinch Roll Shaft with E ring.
8. Slide in the Front Pinch Roll Cover the Eject Pinch Roll Shaft. Secure the Cover to the Shaft with two screws.
9. Install the Eject Pinch Roll Shaft Assembly. (Refer to "Eject Pinch Roll Shaft Assembly" on page 100)

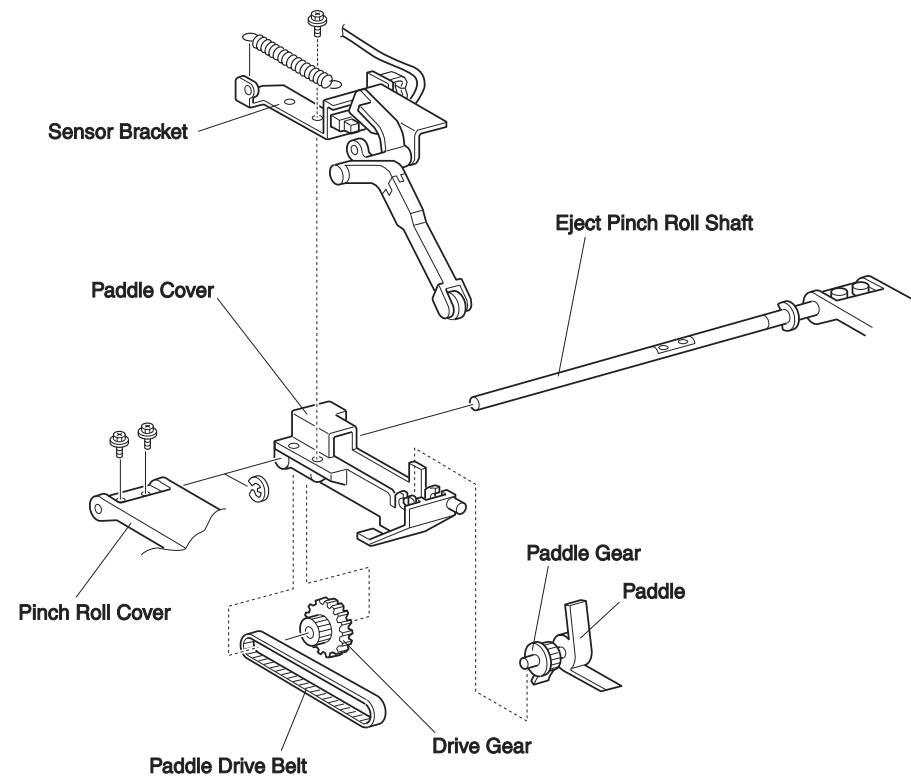

SER819XA

**Figure 3-66. Paddle Drive Belt**

### 3.4.58 Stapler Assembly

Refer to the exploded diagram (Figure 4-38, "Stapler" on page 185).

#### 3.4.58.1 Removal

1. Remove the L/H Cover. (Refer to "L/H Cover" on page 43)
2. Remove the Front Cover Inner Assembly. (Refer to "Front Cover Inner Assembly" on page 41)
3. Push the Stapler Assembly to the front of the HCS.
4. Pull out J862 from the Stapler Assembly.
5. Set the wire harness clip off from the side of the Stapler Assembly.
6. Secure two screws holding the Stapler Assembly to the Slider Bracket and remove the Stapler Assembly.
7. Release the wire harness from the wire harness clip at the back of the Stapler Assembly.

#### 3.4.58.2 Installation

1. Place the Stapler Assembly close to the Slider Bracket.
2. Let the wire harness through the wire clip close the Stapler Assembly.
3. Ensure the tab on the back of the Stapler comes through the cutout of the Slider Bracket and install the Stapler Assembly to the Bracket.
4. Secure the Assembly to the Rail with two screws.
5. Install the Wire Harness Clip to the side of the Stapler Assembly.
6. Connect J862 to the Stapler Assembly.
7. Install the Front Cover Inner Assembly. (Refer to "Front Cover Inner Assembly" on page 41)
8. Install the L/H Cover. (Refer to "L/H Cover" on page 43)

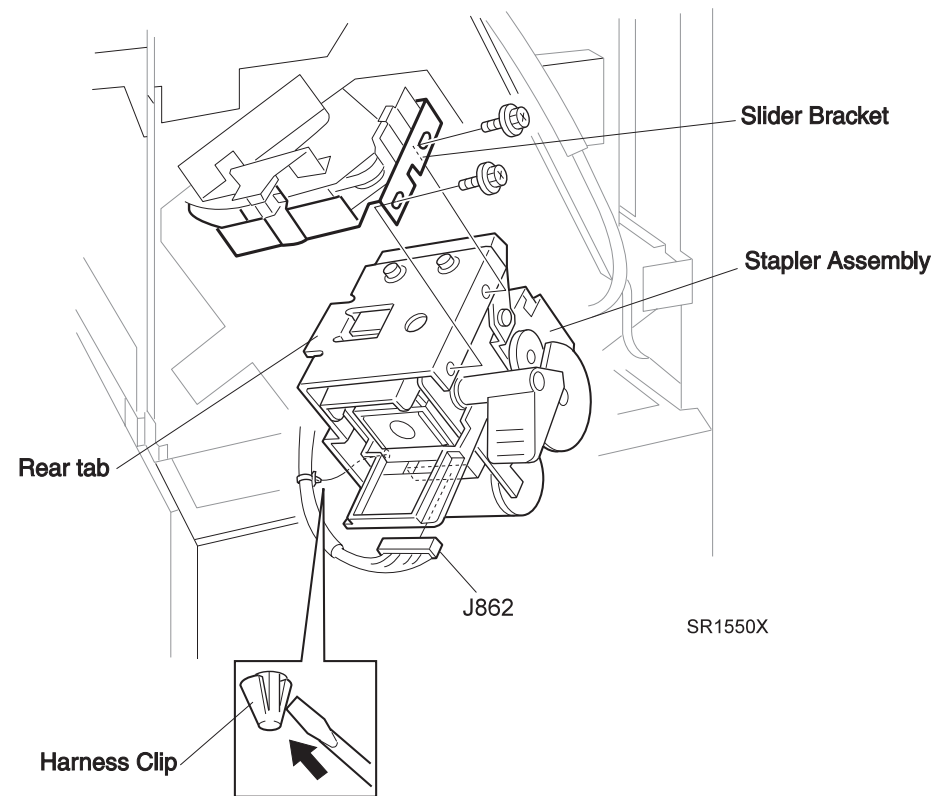

Figure 3-67. Stapler Assembly

### 3.4.59 Stapler Position Sensors

Refer to the exploded diagram (Figure 4-38, "Stapler" on page 185).

#### 3.4.59.1 Removal

1. Remove the Stapler Assembly. (Refer to "Stapler Position Sensors" on page 104)
2. Remove the Rear Cover. (Refer to "Rear Cover" on page 46)
3. Slide the Stapler Transport Motor Drive Belt off from the Drive Pulley. (Refer to "Stapler Transport Motor Drive Belt" on page 119)
4. Remove P833, P834, P835 from the Stapler Sensors. Remove the wire harness from the clips of the Stapler Rail.
5. Remove two screws on the rear and front of the HCS holding the Stapler Rail to the HCS frame.
6. Place the Stapler Rail on the flat place.
7. Remove three screws securing the Sensor Bracket to the Stapler Rail and remove the Brackets along with the Sensor.
8. Set the Sensor Latches off, which holds the Sensor to the Bracket, and remove the Sensor. (Figure 2)

#### 3.4.59.2 Installation

1. Place the Sensors as shown in the Figure 3-68 and insert them with latches ahead to the cutouts of three Sensor Bracket.
2. Install the Sensor Brackets to the Stapler Rail and secure with screws.
3. Install the Stapler Rail to the HCS frame.
4. Secure the Rail to the Frame with two screws.
5. Connect P833 to the Front Corner Sensor. Connect P834 to the Front Edge Sensor. Connect P835 to the Rear Edge Sensor.
6. Let the wire harness through the harness clip on the top of the Stapler Rail.
7. Slide in the Stapler Transport Motor Drive Belt to the Drive Pulley. (Refer to "Stapler Transport Motor Drive Belt" on page 119)

8. Install the Rear Cover. (Refer to "Rear Cover" on page 46)
9. Install the Stapler Assembly. (Refer to "Stapler Position Sensors" on page 104)

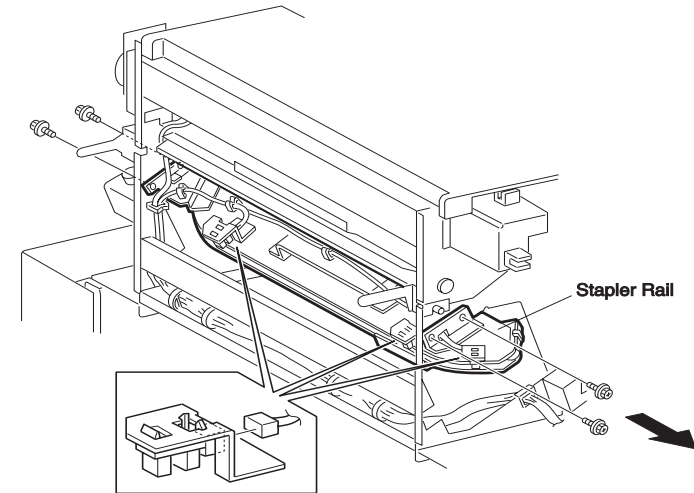

Figure 1

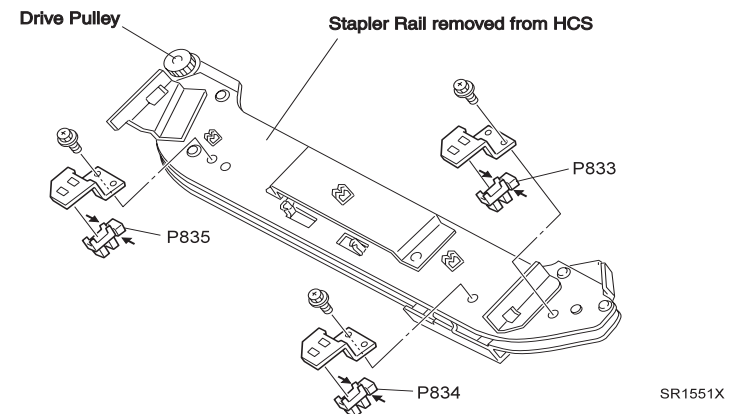

Figure 2

Figure 3-68. Stapler Position Sensors



### 3.4.60 Top Cover Assembly

Refer to the exploded diagram (Figure 4-39, "Transport" on page 186).

#### 3.4.60.1 Removal

1. Open the Top Cover.
2. Remove the screw holding the Cover Bracket to the Cover.
3. Remove the pivot from the pivot hole and shift off the Top Cover and remove the Top Cover from the HCS frame.

#### 3.4.60.2 Installation

1. Insert the Top Cover to the pivot hole of the HCS.
2. Ensure the position-marking hole of the Bracket comes to the position-marking tan of the Cover, and determine the position by pulling the Bracket up against the Top Cover.
3. Secure the Bracket to the Top Cover with a screw.
4. Close the Top Cover.

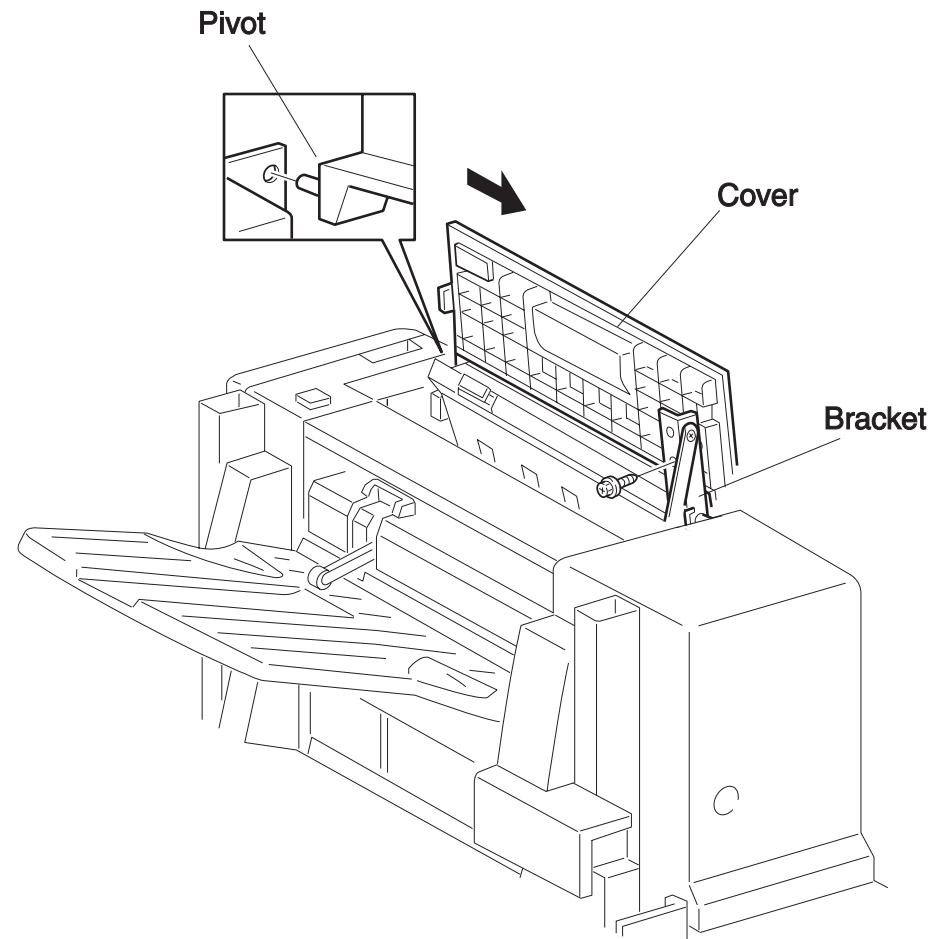

SER787XA

Figure 3-69. Top Cover Assembly

### 3.4.61 Compiler Tray Exit Sensor

Refer to the exploded diagram (Figure 4-39, "Transport" on page 186).

#### 3.4.61.1 Removal

1. Open the Top Cover.
2. Release the latches on the top of the Compiler Tray Exit Sensor and remove the Sensor from the Transport Chute.
3. Pull out J838 from the Compiler Tray Exit Sensor.

#### 3.4.61.2 Installation

1. Open the Top Cover.
2. Place the Compiler Tray Exit Sensor to the back of the Transport Chute as shown in the Figure 3-70.
3. Connect J838 to the Compiler Tray Exit Sensor.
4. Ensure the Sensor Actuator comes into the cutout of the Chute.
5. Install the Sensor to the Chute.
6. Close the Top Cover.

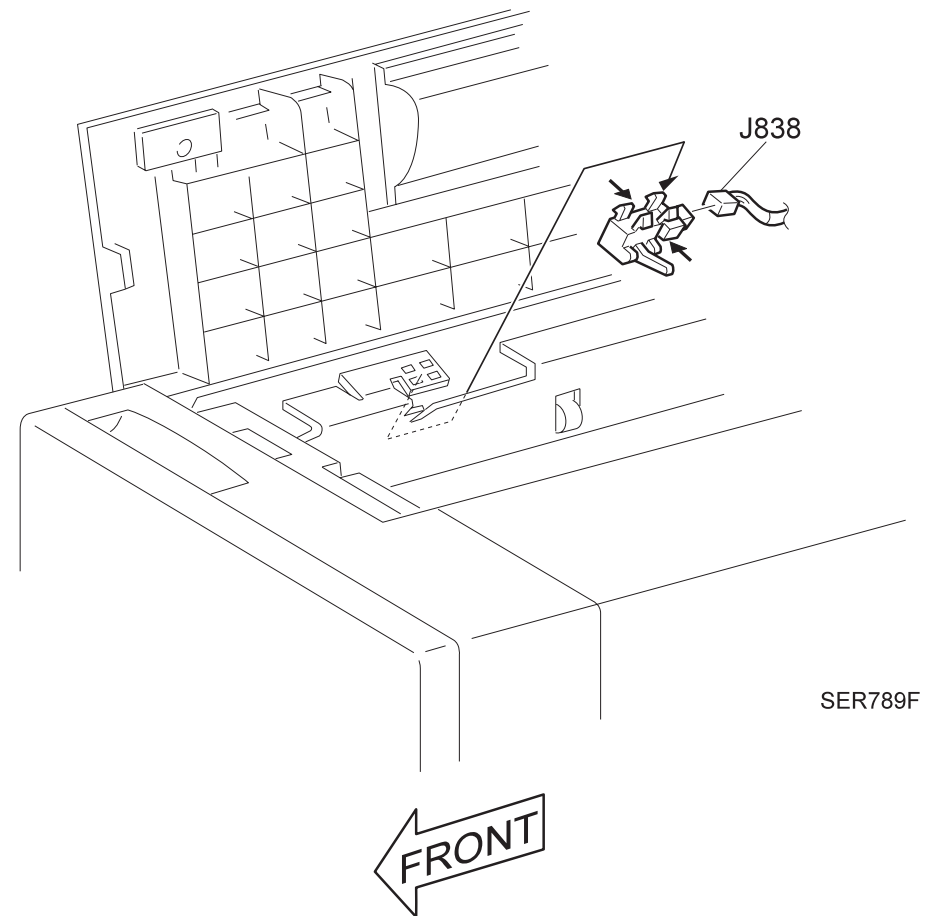

Figure 3-70. Compiler Tray Exit Sensor

### 3.4.62 Upper Transport Chute Assembly

Refer to the exploded diagram (Figure 4-39, "Transport" on page 186).

#### 3.4.62.1 Removal

1. Remove the Transport Motor Bracket. (Follow the instructions in "Transport Motor Drive Belt" on page 120 from step 1 to step 5)
2. Remove J838 from the Compiler Tray Exit Sensor and remove the wire harness from the clip on the top of the Upper Transport Chute Assembly.
3. Remove the screw securing the Upper Transport Chute support arm to the Top Cover Assembly.
4. Remove the screw securing the front side of the Upper Transport Chute to the HCS.
5. Remove the screw securing the rear side of the Upper Transport Chute to the HCS.
6. Remove the Upper Transport Chute Assembly from the HCS.

#### 3.4.62.2 Installation

1. Place the Upper Transport Chute Assembly as shown in the Figure 3-71 and install it to the HCS.
2. Secure the rear side of the Upper Transport Chute to the rear side of the HCS frame.
3. Secure the front side of the Upper Transport Chute to the front side of the HCS frame.
4. Push support arm onto the Top Cover Assembly and secure it with a screw.
5. Connect J838 to the Compiler Tray Exit Sensor.
6. Let the wire harness through the clip on the top of the Upper Transport Chute Assembly.
7. Install the Transport Motor Bracket. (Refer to "Transport Motor Drive Belt" on page 120)

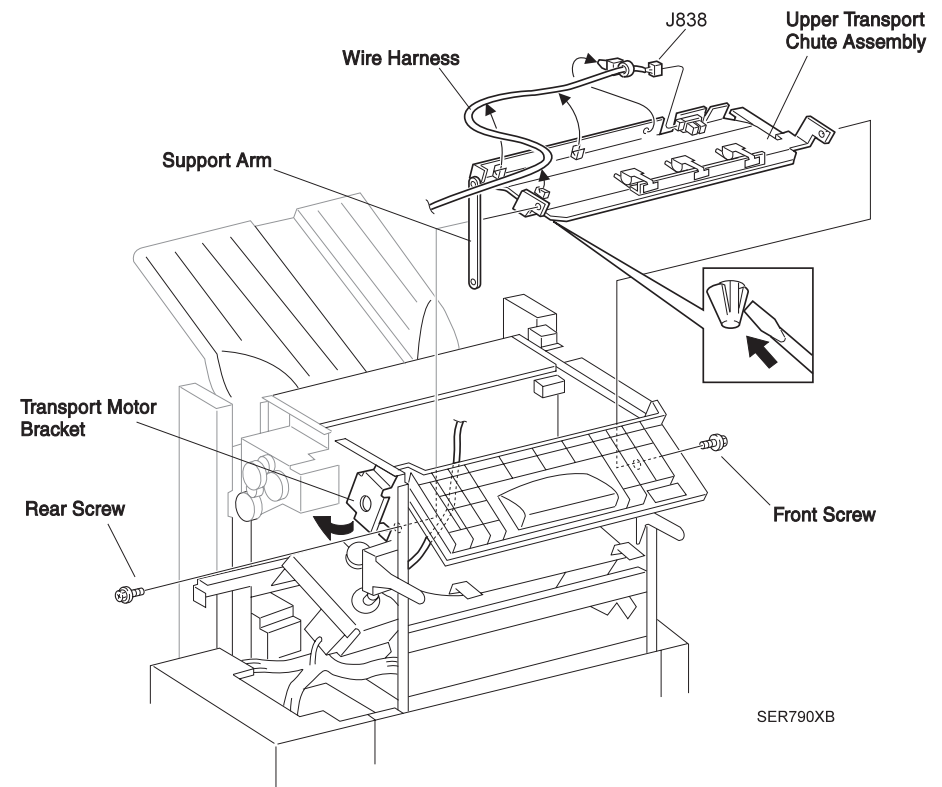

Figure 3-71. Upper Transport Chute Assembly

### 3.4.63 Top and Front Cover Interlock Switches

Refer to the exploded diagram (Figure 4-40, "Front Frame" on page 187).

#### 3.4.63.1 Removal

1. Remove the Front Cover Inner Assembly. (Refer to "Front Cover Inner Assembly" on page 41)
2. Open the Top Cover.
3. Pull out J271 from the Top Cover Interlock Switch.
4. Lift the Top Cover Interlock Switch with the slotted screwdriver and remove it from the HCS frame.
5. Pull out J270 from the Front Cover Interlock Switch.
6. Lift the Front Cover Interlock Switch with the slotted screwdriver and remove it from the HCS frame.

#### 3.4.63.2 Installation

1. Insert the Front Cover Interlock Switch to the cutout of the HCS frame.
2. Snap the Switch in.
3. Connect J270 to the Front Cover Interlock Switch.
4. Insert the Top Cover Interlock Switch to the cutout of the HCS frame.
5. Snap the Switch in.
6. Connect J271 to the Top Cover Interlock Switch.
7. Install the Front Cover Inner Assembly. (Refer to "Front Cover Inner Assembly" on page 41)

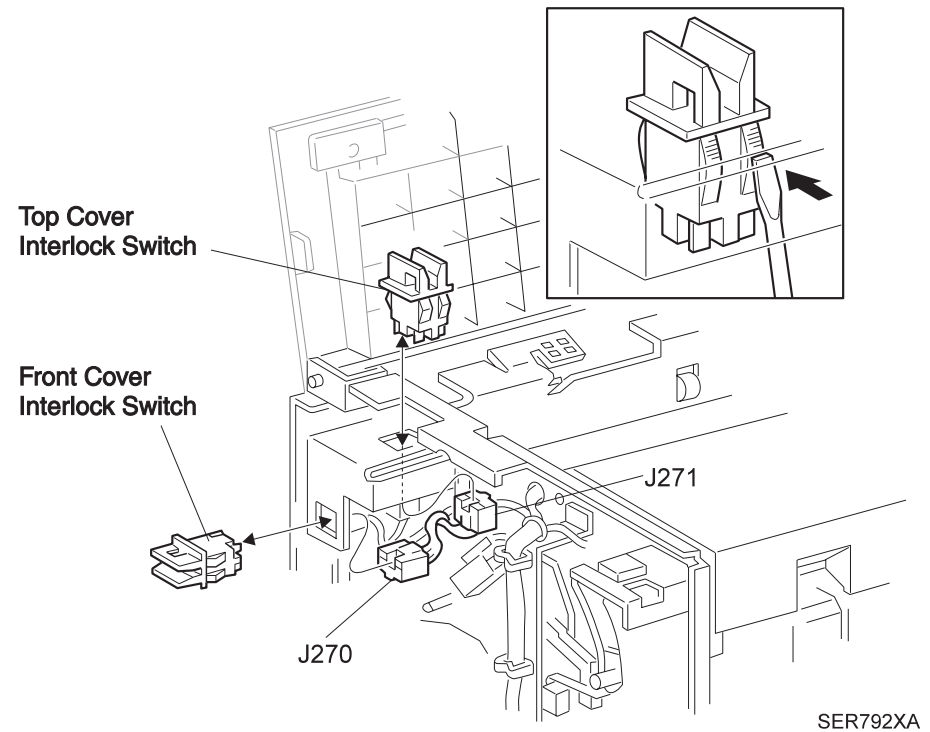

Figure 3-72. Top and Front Cover Interlock Switches

### 3.4.64 Compiler Cover and Safety Interlock Switches

Refer to the exploded diagram (Figure 4-40, "Front Frame" on page 187).

#### 3.4.64.1 Removal

1. Remove the Front Cover Inner Assembly. (Refer to "Front Cover Inner Assembly" on page 41)
2. Remove the Unload While Run Switch. (Refer to "Unload While Run Switch" on page 111)
3. Remove, if necessary, two screws securing the Harness Holder to the HCS frame and let the Holder away not to obstruct the removal procedure.
4. Pull out J855 from the Compiler Safety Switch.
5. Remove two screws securing the Safety Switch to the HCS frame and remove the Switch.
6. Pull out J272A and J272B from two Compiler Cover Interlock Switches.
7. Remove two screws securing the Interlock Switches to the HCS frame and remove the Switches.

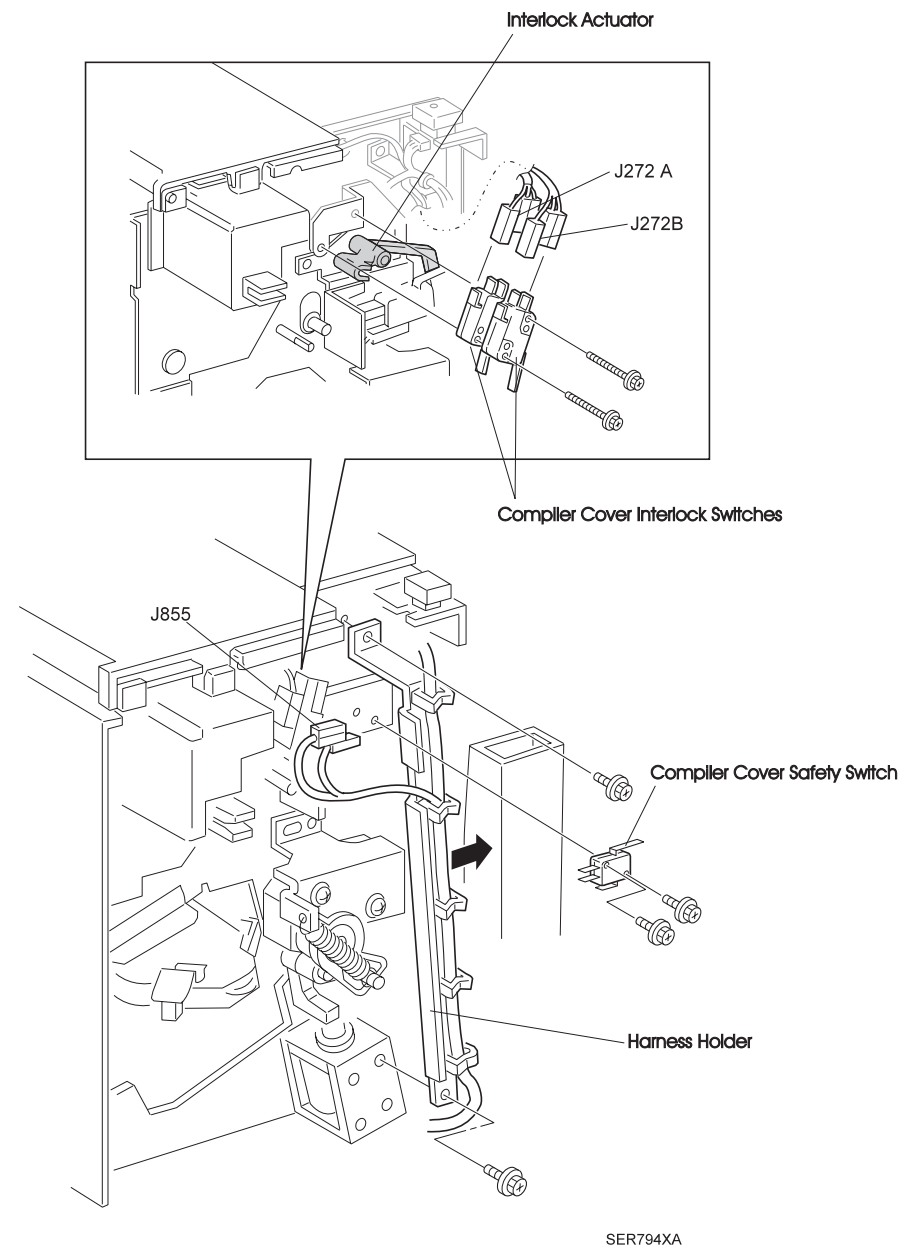

Figure 3-73. Compiler Cover and Safety Interlock Switches

**3.4.64.2 Installation**

1. Place two Compiler Cover Interlock Switches as shown in the Figure 3-73.
2. Ensure the Switch Actuator is under the Interlock Actuator and install two Compiler Cover Interlock Switches to the HCS frame.
3. Connect J272A to the Compiler Cover Interlock Switch next to the frame.
4. Connect J272B to the other Compiler Cover Interlock Switch.
5. Ensure the Switch Actuator is under the Eject Chute Assembly and install two Compiler Cover Interlock Switches to the HCS frame.
6. Secure the Safety Switch to the HCS frame with two screws.
7. Connect J855B to the Safety Switch.
8. If the Harness Holder is removed, install it and secure it to the HCS frame with two screws.
9. Install the Unload While Run Switch. (Refer to "Unload While Run Switch" on page 111)
10. Install the Front Cover Inner Assembly. (Refer to "Front Cover Inner Assembly" on page 41)

### 3.4.65 Unload While Run Switch

Refer to the exploded diagram (Figure 4-40, "Front Frame" on page 187).

#### 3.4.65.1 Removal

1. Remove the Front Cover Inner Assembly. (Refer to "Front Cover Inner Assembly" on page 41)
2. Remove the screw holding Switch Bracket to the HCS frame and remove the Bracket.
3. Pull out J836 from the Switch.
4. Remove the screw holding the Switch to the Bracket and remove the Switch.

#### 3.4.65.2 Installation

1. Install the Unload While Run Switch to the Switch Bracket.
2. Secure the Switch to the Bracket.
3. Connect J836 to the Switch.
4. Install Bracket to the HCS frame and secure the Bracket to the frame with a screw.
5. Install the Front Cover Inner Assembly. (Refer to "Front Cover Inner Assembly" on page 41)

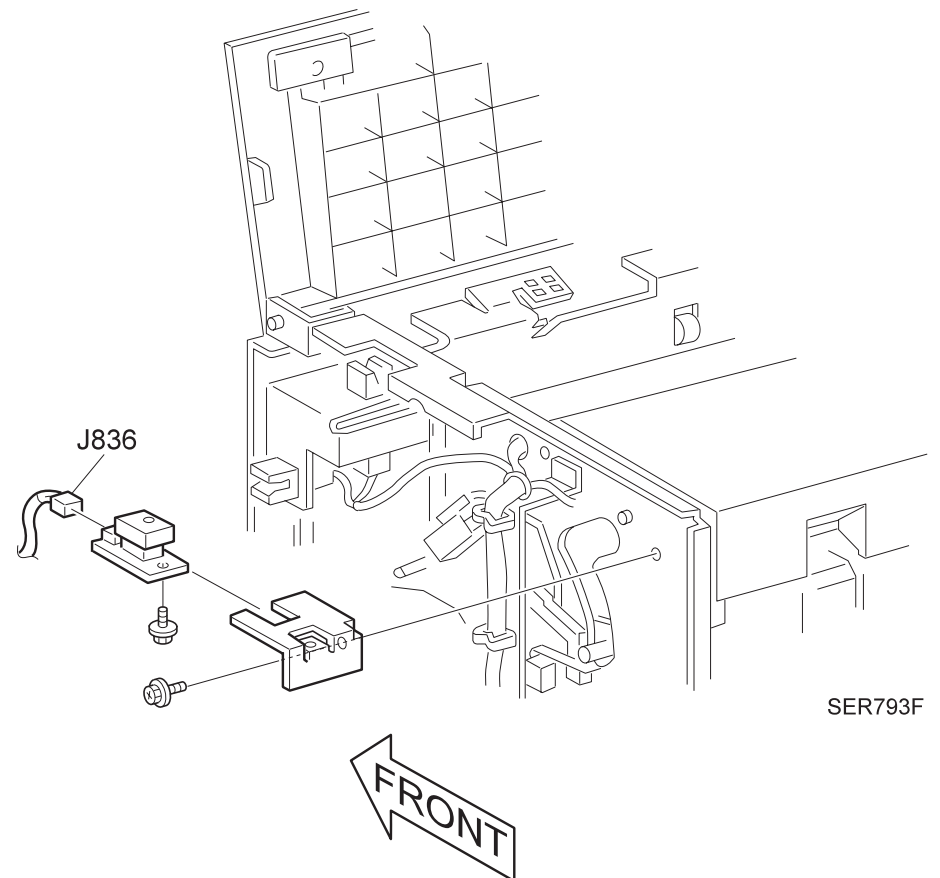

Figure 3-74. Unload While Run Switch

### 3.4.66 End Wall Motor

Refer to the exploded diagram (Figure 4-40, "Front Frame" on page 187).

#### 3.4.66.1 Removal

1. Remove the Front Cover Inner Assembly. (Refer to "Front Cover Inner Assembly" on page 41)
2. Remove the Unload While Run Switch. (Refer to "Unload While Run Switch" on page 111)
3. Remove two screws securing the Harness Holder and remove the Holder.
4. Remove the screw securing the Harness Clip to the End Wall Solenoid.
5. Remove the End Wall Spring.
6. Remove two screws securing the End Wall Motor Bracket to the HCS frame and remove the Bracket along with the End Wall Motor.
7. Release the End Wall Motor wire harness from the harness clip.
8. Pull out J868.
9. Remove two screws securing the End Wall Motor to the Bracket and remove the Motor.

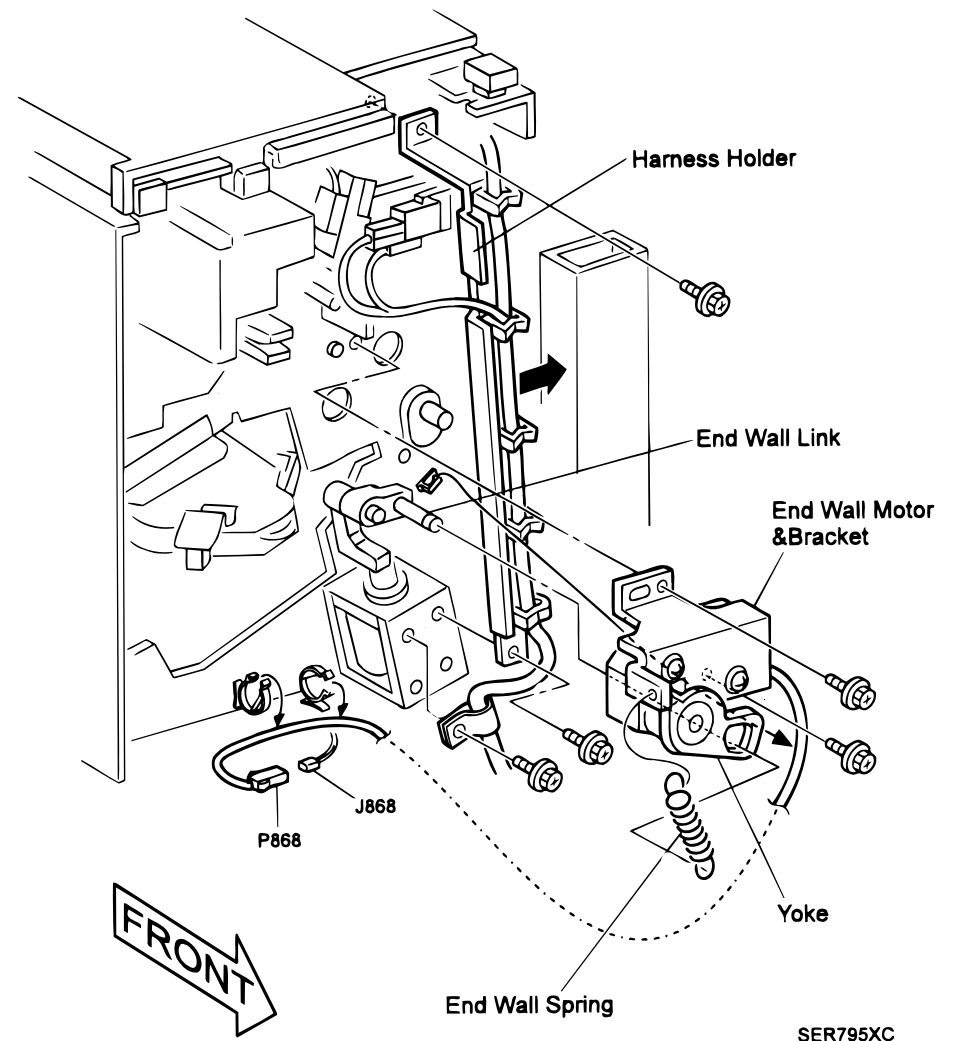

Figure 3-75. End Wall Motor



**3.4.66.2 Installation**

1. Install the End Wall Motor to the Motor Bracket.
2. Secure the Motor to the Bracket with two long screws.
3. Ensure the End Wall Link is inside the End Wall Motor Bracket and install the End Wall Motor Bracket to the HCS frame.
4. Secure the End Wall Motor Bracket to the front side of the HCS frame with two screws.
5. Hang the one side of the End Wall Spring to the End Wall Motor Bracket and the other to the end of the End Wall Link.
6. Let the End Wall Motor wire harness through the harness clip.
7. Connect J868 to the Switch.
8. Install the Harness Holder and secure the Holder to the HCS frame with two screws.
9. Install the Harness Clip to the End Wall Solenoid and secure it with a screw.
10. Install the Unload While Run Switch. (Refer to "Unload While Run Switch" on page 111)
11. Install the Front Cover Inner Assembly. (Refer to "Front Cover Inner Assembly" on page 41)

### 3.4.67 Transport Motor

Refer to the exploded diagram (Figure 4-41, "Rear Frame 1" on page 188).

#### 3.4.67.1 Removal

1. Remove the HCS from the printer. (Refer to "Finisher Stapler" on page 35)
2. Remove the Rear Cover. (Refer to "Rear Cover" on page 46)
3. Pull out J257 from the Transport Motor.
4. Remove two screws securing the Tie Transport Motor to the Motor Bracket and remove the Motor.

#### 3.4.67.2 Installation

1. Install the Transport Motor to the Motor Bracket.
2. Secure the Motor to the Bracket with two screws.
3. Connect J257 to the Transport Motor.
4. Install the Rear Cover. (Refer to "Rear Cover" on page 46)
5. Install the HCS to the printer. (Refer to "Finisher Stapler" on page 35)

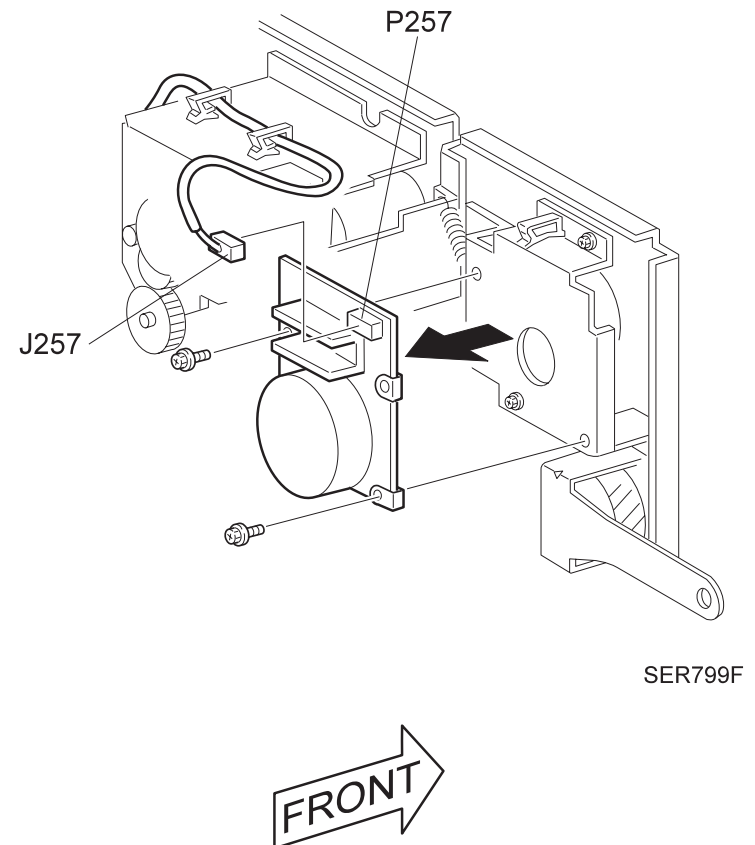

Figure 3-76. Transport Motor

### 3.4.68 Set Clamp Motor

Refer to the exploded diagram (Figure 4-41, "Rear Frame 1" on page 188).

#### 3.4.68.1 Removal

1. Remove the Eject Bracket Assembly. (Refer to "Eject Bracket Assembly" on page 121)
2. Remove the Finisher Stapler PWB Cover. (Refer to "Finisher Stapler PWB Cover and Connector Cover" on page 48)
3. Pull out J864 and J842.
4. Remove two screws securing the Motor Bracket to the HCS frame and remove the Bracket.
5. Remove the Set Clamp Drive Belt from the Motor Pulley and remove the Motor Bracket.
6. Remove E ring binding Shaft Pulley to the Motor and remove the Shaft Pulley.
7. Remove two screws securing the Set Clamp Motor to the Motor Bracket and remove the Motor.

#### 3.4.68.2 Installation

1. Install the Set Clamp Motor to the Motor Bracket with two screws.
2. Install the Shaft Pulley to the Motor Shaft as shown in the Figure 3-77.
3. Secure the Pulley to the Shaft with E ring.
4. Hang the Set Clamp Drive Belt to the Shaft Pulley and install the Motor Bracket to the HCS frame.
5. Secure the Motor Bracket to the HCS frame with two screws.
6. Connect J864 and J842.
7. Install the Finisher Stapler PWB Cover. (Refer to "Finisher Stapler PWB Cover and Connector Cover" on page 48)
8. Install the Eject Bracket Assembly. (Refer to "Eject Bracket Assembly" on page 121)

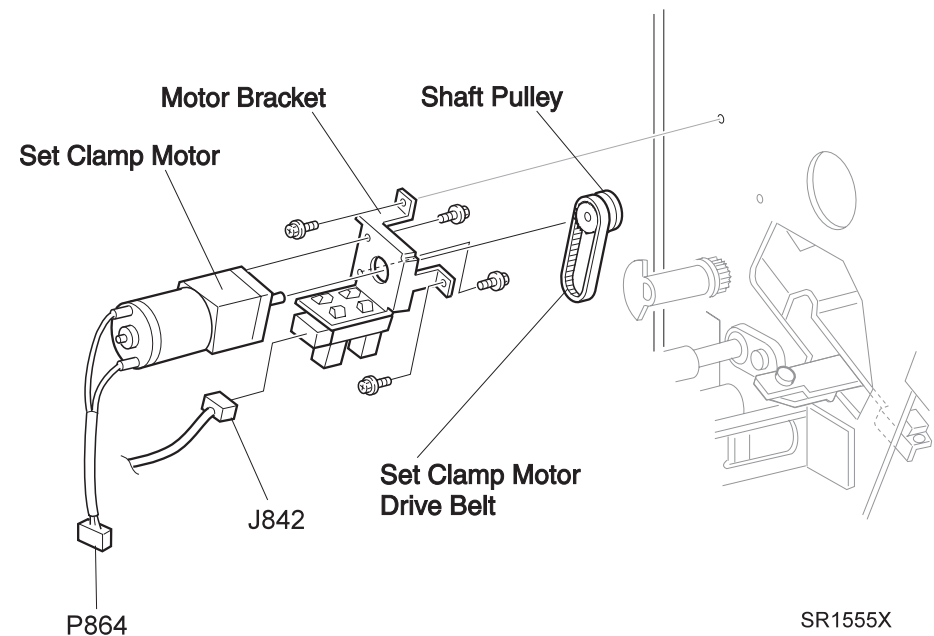

Figure 3-77. Set Clamp Motor

### 3.4.69 Set Clamp Motor Drive Belt

Refer to the exploded diagram (Figure 4-41, "Rear Frame 1" on page 188).

#### 3.4.69.1 Removal

1. Remove the Set Clamp Motor. (Refer to "Set Clamp Motor" on page 115)
2. Remove the Set Clamp Motor Drive Belt from the Eject Pulley.

#### 3.4.69.2 Installation

1. Hang the Motor Drive Belt on the Eject Pulley.
2. Install the Set Clamp Motor. (Refer to "Set Clamp Motor" on page 115)

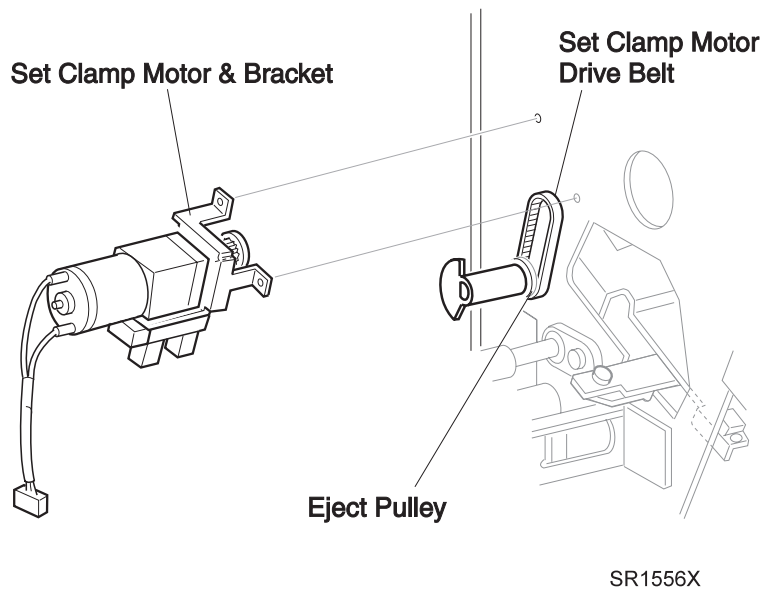

Figure 3-78. Set Clamp Motor Drive Belt

### 3.4.70 Set Clamp Home Sensor

Refer to the exploded diagram (Figure 4-41, "Rear Frame 1" on page 188).

#### 3.4.70.1 Removal

1. Remove the Set Clamp Motor. (Refer to "Set Clamp Motor" on page 115)

**NOTE:** For the removal of the Set Clamp Home Sensor, there is no need for the Motor to be removed from the Bracket.

2. Release the latches, which secures the Sensor to the Bracket, and remove the Sensor.

#### 3.4.70.2 Installation

1. Insert the Set Clamp Home Sensor to the Bracket as shown in the Figure 3-79.
2. Insert the hook into the hole of the Motor Bracket and push the latches in.
3. Install the Set Clamp Motor. (Refer to "Set Clamp Motor" on page 115)

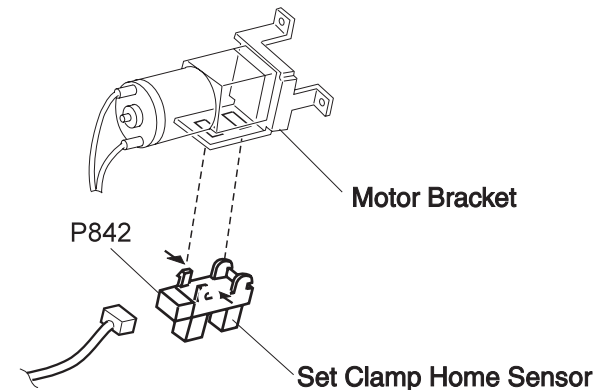

Figure 3-79. Set Clamp Home Sensor

### 3.4.71 Eject Motor

Refer to the exploded diagram (Figure 4-41, "Rear Frame 1" on page 188).

#### 3.4.71.1 Removal

1. Remove the HCS from the printer. (Refer to "Finisher Stapler" on page 35)
2. Remove the Rear Cover. (Refer to "Rear Cover" on page 46)
3. Release the wire harness under the Harness Bracket.
4. Remove three screws securing the Harness Bracket to the HCS frame and remove the Bracket.
5. Pull out J258.
6. Remove three screws securing the Eject Motor Bracket the HCS frame.
7. Remove the Motor Shaft Pulley from the Eject Motor Drive Belt and remove the Bracket and the Motor.
8. Remove two screws securing the Eject Motor to the Motor Bracket and remove the Motor.

#### 3.4.71.2 Installation

1. Install the Eject Motor to the Eject Motor Bracket as shown in the Figure 3-80.
2. Secure the Motor to the Bracket with two screws.
3. Hang the open end of the Eject Motor Drive Belt to the Pulley of the Motor Shaft and install the Motor Bracket to the HCS frame.
4. Secure the Motor Bracket to the HCS frame with three screws.

**NOTE:** Do not tighten the screws for this moment.

5. Keeping the Drive Belt strained by pushing the Eject Motor down, fasten three screws.
6. Connect J258.
7. Install the Harness Bracket to the HCS frame and secure it to the frame with three screws.

8. Install the wire harness to the Harness Bracket by putting it under clips.
9. Install the Rear Cover. (Refer to "Rear Cover" on page 46)
10. Install the HCS to the printer. (Refer to "Finisher Stapler" on page 35)

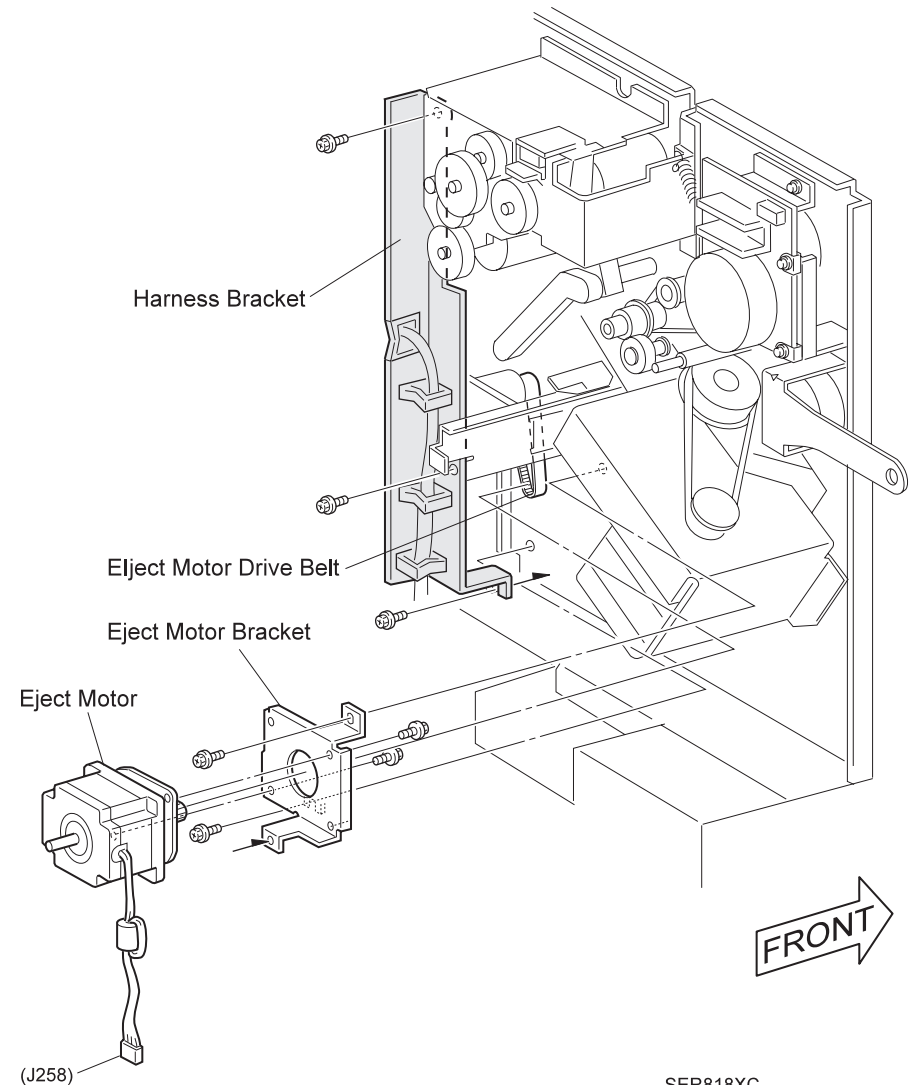

Figure 3-80. Eject Motor

### 3.4.72 Stapler Transport Motor

Refer to the exploded diagram (Figure 4-41, "Rear Frame 1" on page 188).

#### 3.4.72.1 Removal

1. Remove the AC cable and the HCS interface cable from the printer.
2. Remove the Rear Cover. (Refer to "Rear Cover" on page 46)
3. Pull out J886.
4. Remove two screws securing the Stapler Transport Motor to the Motor Bracket and remove the Motor.

#### 3.4.72.2 Installation

1. Insert the Shaft of the Motor to the hole of the Motor Bracket.
2. Hang the Stapler Motor Drive Belt to the Shaft Gear.
3. Adjust the position of the Motor as two threaded screw holes of the Motor comes at the same position of those of the Motor Bracket.
4. Secure the Motor to the Bracket with two screws.
5. Connect J886.
6. Install the Rear Cover. (Refer to "Rear Cover" on page 46)
7. Install the AC cable and the HCS interface cable to the printer.

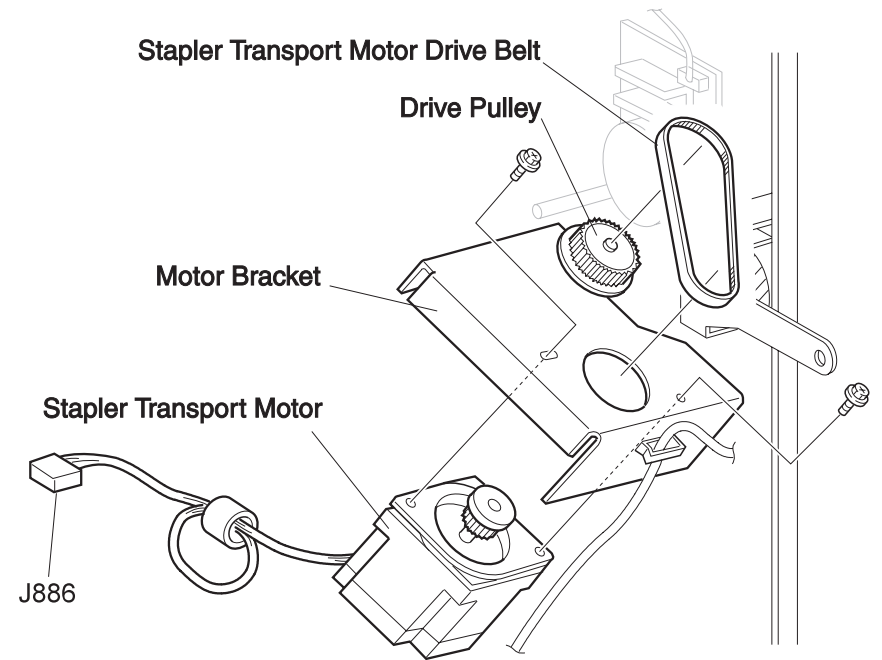

**Figure 3-81. Stapler Transport Motor**

### 3.4.73 Stapler Transport Motor Drive Belt

Refer to the exploded diagram (Figure 4-41, "Rear Frame 1" on page 188).

#### 3.4.73.1 Removal

1. Remove the Stapler Transport Motor. (Refer to "Stapler Transport Motor" on page 118)
2. Remove the Drive Belt from the Drive Pulley.

#### 3.4.73.2 Installation

1. Prepare the Stapler Transport Motor Drive Belt as the flat side faces out. (Concavo-convex side should faces in.)
2. Hang the Belt on the Drive Pulley.
3. Install the Stapler Transport Motor. (Refer to "Stapler Transport Motor" on page 118)

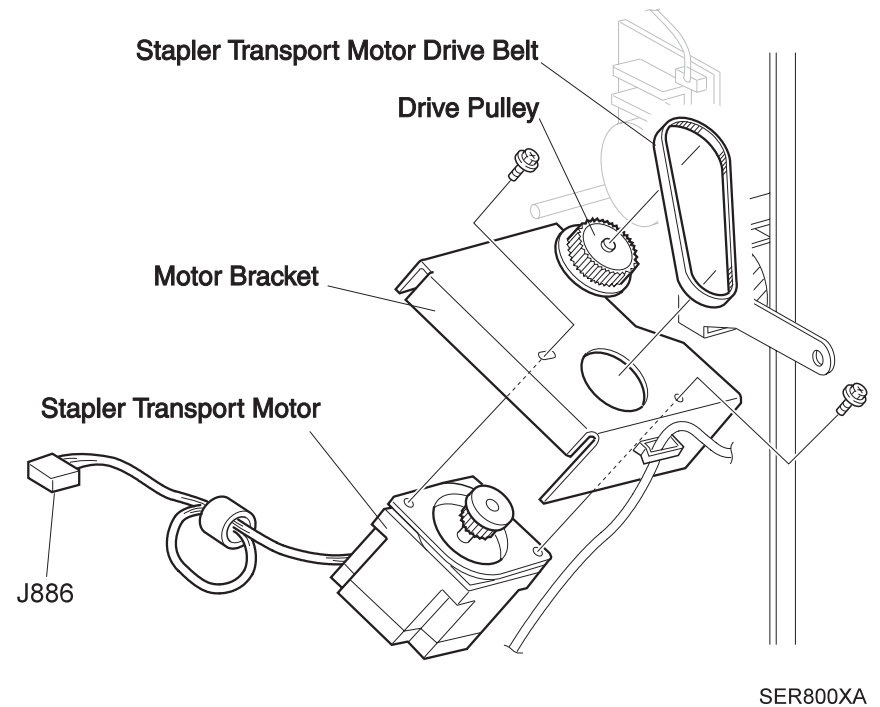

Figure 3-82. Stapler Transport Motor Drive Belt

### 3.4.74 Transport Motor Drive Belt

Refer to the exploded diagram (Figure 4-42, "Rear Frame 2" on page 189).

#### 3.4.74.1 Removal

1. Remove the HCS from the printer. (Refer to "Finisher Stapler" on page 35)
2. Remove the Rear Cover. (Refer to "Rear Cover" on page 46)
3. Remove the Transport Motor. (Refer to "Transport Motor" on page 114)
4. Remove the Tension Spring from the Transport Motor Bracket.
5. Remove five screws securing the Transport Motor Bracket to the HCS frame and remove the Bracket.
6. Remove E ring binding two gears at each corner of the Belt and remove the gear.
7. Remove the Transport Motor Drive Belt.

#### 3.4.74.2 Installation

1. Install the Transport Motor Drive Belt.
2. Install the gears at each corner of the Belt and bind them with E ring.
3. Install the Transport Motor Bracket to the HCS frame and secure it with five screws.
4. Hang the Tension Spring on the Transport Motor Bracket.
5. Install the Transport Motor. (Refer to "Transport Motor" on page 114)
6. Install the Rear Cover. (Refer to "Rear Cover" on page 46)
7. Install the HCS to the printer. (Refer to "Finisher Stapler" on page 35)

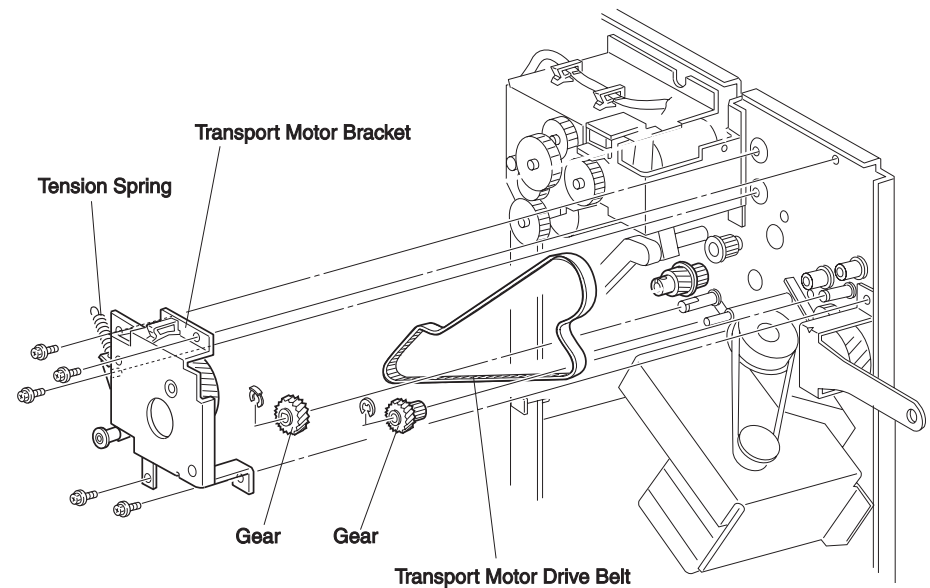

SER817XA

**Figure 3-83. Transport Motor Drive Belt**



### 3.4.75 Eject Bracket Assembly

Refer to the exploded diagram (Figure 4-43, "Rear Frame 3" on page 190).

#### 3.4.75.1 Removal

1. Remove the HCS from the printer. (Refer to "Finisher Stapler" on page 35)
2. Remove the Rear Cover. (Refer to "Rear Cover" on page 46)
3. Release the wire harness from the Harness Bracket Assembly.
4. Remove three screws securing the Harness Bracket Assembly to the HCS frame and remove the Harness Bracket Assembly.
5. Remove the Offset Home Sensor. (Refer to "Offset Home Sensor" on page 124)
6. Remove the Eject Clamp Sensor. (Refer to "Eject Clamp Sensor" on page 123)
7. Remove Tension Spring from the Eject Bracket Assembly.
8. Remove four screws securing the Eject Bracket Assembly to the HCS frame and remove the Eject Bracket Assembly.

#### 3.4.75.2 Installation

1. Place the Eject Clamp Actuator as the Cam Clamp Spring touches the actuator as shown in the Figure 3-84.
2. Install the Eject Bracket Assembly to the HCS frame as the tab of the HCS frame goes in the long slot of the Eject Bracket Assembly.
3. Install the Lever as the Lever touches the Clamp Up Lever as shown in the Figure 3-84.
4. Put the protrusion of the Offset Lever on the groove of the Offset Cam.
5. Secure the Eject Bracket Assembly to the HCS frame with four screws.
6. Hang the Tension Spring on the Eject Bracket Assembly.
7. Install the Eject Clamp Sensor.(Refer to "Eject Clamp Sensor" on page 123)

8. Install the Offset Home Sensor. (Refer to "Offset Home Sensor" on page 124)
9. Install the Harness Bracket Assembly to the HCS frame with three screws.
10. Insert the wire harness under the Clip on the Harness Bracket.
11. Install the Rear Cover. (Refer to "Rear Cover" on page 46)
12. Install the HCS to the printer. (Refer to "Finisher Stapler" on page 35)

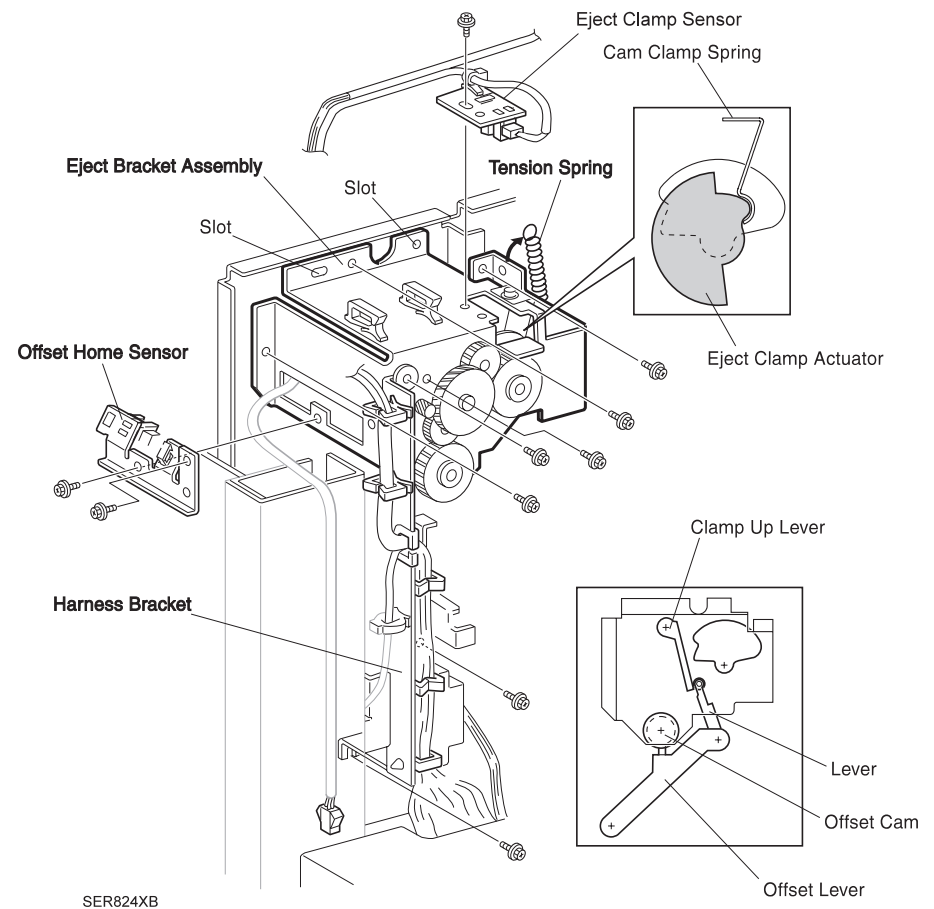

Figure 3-84. Eject Bracket Assembly

### 3.4.76 Eject Clamp Offset Motor

Refer to the exploded diagram (Figure 4-43, "Rear Frame 3" on page 190).

#### 3.4.76.1 Removal

1. Remove the Eject Bracket Assembly. (Refer to "Eject Bracket Assembly" on page 121)
2. Remove E ring binding the One Way Gear to the Offset Cam Assembly and remove the Gear.
3. Remove E ring binding the One Cam Assembly Bearing and remove the Gear.
4. Remove the Offset Cam Assembly from the Eject Bracket.
5. Remove the E ring binding the Drive Gear and remove the Gear.
6. Remove two Idler Gears.
7. Remove three screws securing the Eject Clamp Offset Motor and remove the Motor from the Eject Bracket Assembly.

#### 3.4.76.2 Installation

1. Install the Eject Clamp Offset Motor to the Eject Bracket Assembly with three screws.
2. Install two Idler Gears.
3. Install the Drive Gear and bind the Drive Gear with E ring.
4. Install the Offset Cam Assembly to the Eject Bracket Assembly as its Actuator faces inner wall of the Eject Bracket Assembly.
5. Install two Bearings to the both ends of the Offset Cam Assembly Shaft.
6. Put E ring on the shorter end of the Offset Cam Assembly Shaft.
7. Install the One Way Gear to the end of the Offset Cam Assembly and bind the Gear to the Shaft with E ring.
8. Install the Eject Bracket Assembly. (Refer to "Eject Bracket Assembly" on page 121)

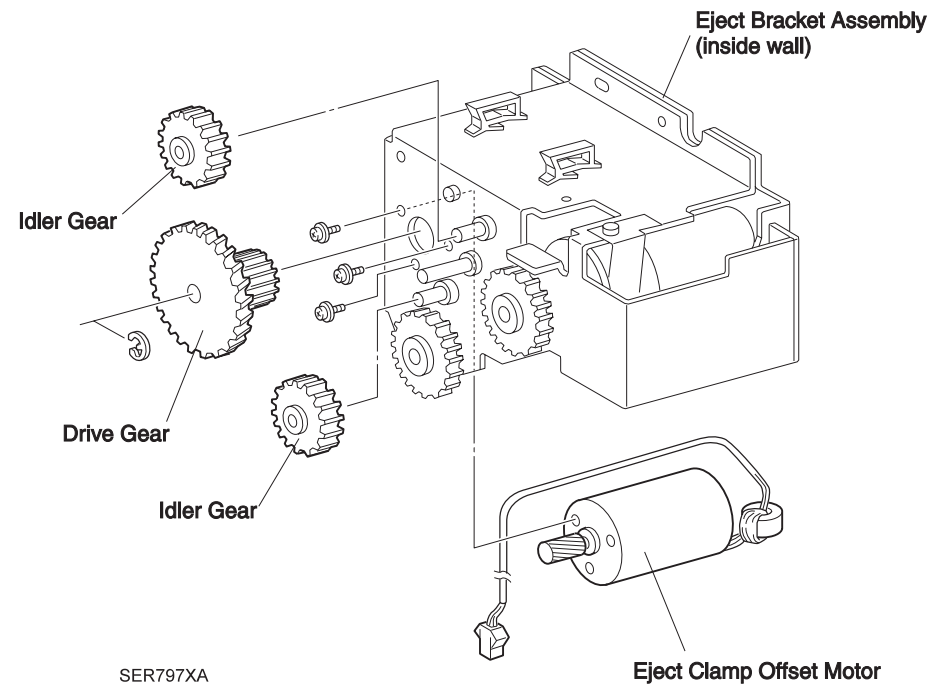

**Figure 3-85. Eject Clamp Offset Motor**

### 3.4.77 Eject Clamp Sensor

Refer to the exploded diagram (Figure 4-43, "Rear Frame 3" on page 190).

#### 3.4.77.1 Removal

1. Remove the Rear Cover. (Refer to "Rear Cover" on page 46)
2. Remove the wire harness from the Wire Clamp on the Eject Bracket.
3. Remove one screw securing the Eject Clamp Sensor Bracket to the Eject Bracket and remove the Sensor Bracket along with the Sensor.
4. Pull out J841 from the Sensor.
5. Release the latches, which secures the Sensor to the Bracket, and remove the Sensor from the Bracket.

#### 3.4.77.2 Installation

1. Place the Eject Clamp Sensor against the Eject Clamp Sensor Bracket as shown in the Figure 3-86 and push the latches into the bracket.
2. Connect J841 to the Sensor.
3. Install the Eject Clamp Sensor to the Eject Bracket.
4. Secure the Sensor Bracket to the Eject Bracket with one screw.
5. Install the wire harness to the Wire Clamp on the Eject Bracket.
6. Install the Rear Cover. (Refer to "Rear Cover" on page 46)

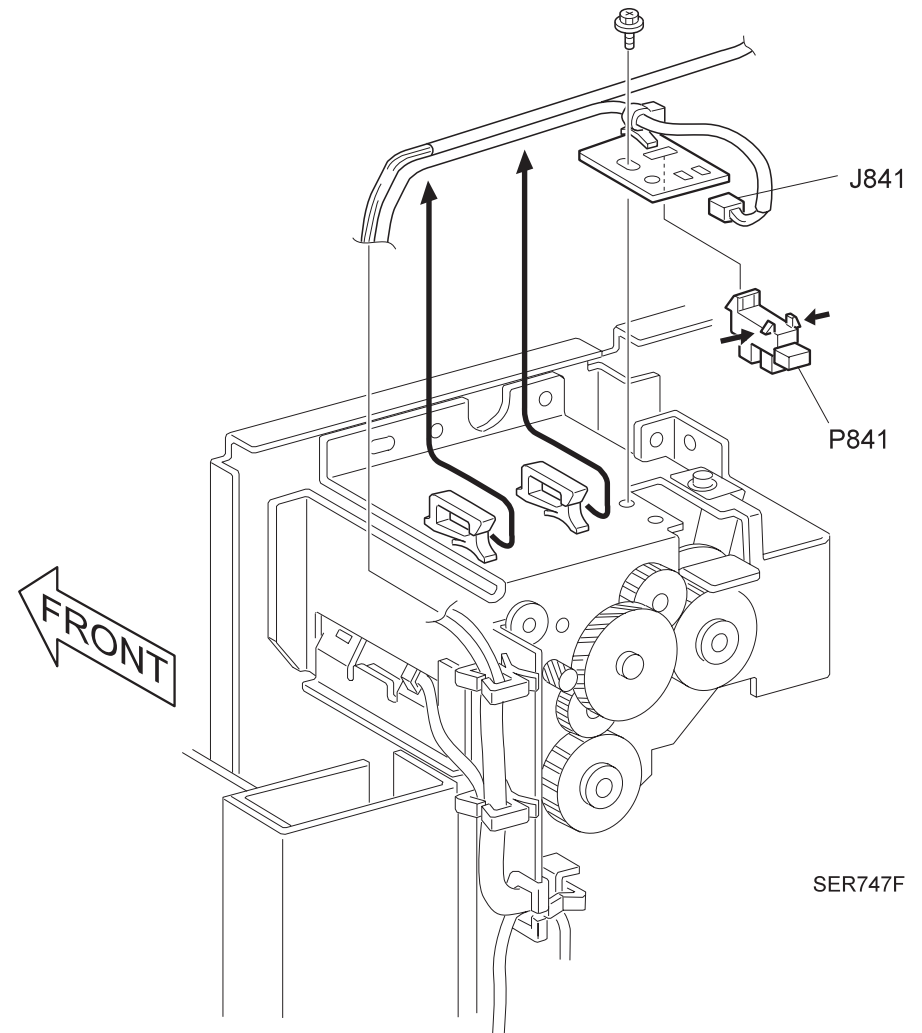

Figure 3-86. Eject Clamp Sensor

### 3.4.78 Offset Home Sensor

Refer to the exploded diagram (Figure 4-43, "Rear Frame 3" on page 190).

#### 3.4.78.1 Removal

1. Remove the Rear Cover. (Refer to "Rear Cover" on page 46)
2. Remove two screws securing the Offset Home Sensor Bracket to the HCS frame and remove the Bracket.
3. Remove the wire harness from the Wire Clamp on the Eject Bracket.
4. Pull out J844 from the Offset Home Sensor.
5. Release the latches, which secures the Sensor to the Bracket, and remove the Sensor from the Bracket.

#### 3.4.78.2 Installation

1. Place the Offset Home Sensor against the Eject Clamp Sensor Bracket as shown in the Figure 3-87 and push the latches into the bracket.
2. Connect J844 to the Sensor.
3. Install the wire harness to the Wire Clamp on the Eject Bracket.
4. Install the Offset Home Sensor Bracket to the HCS frame.
5. Secure the Bracket to the Frame with two screws.
6. Install the Rear Cover. (Refer to "Rear Cover" on page 46)

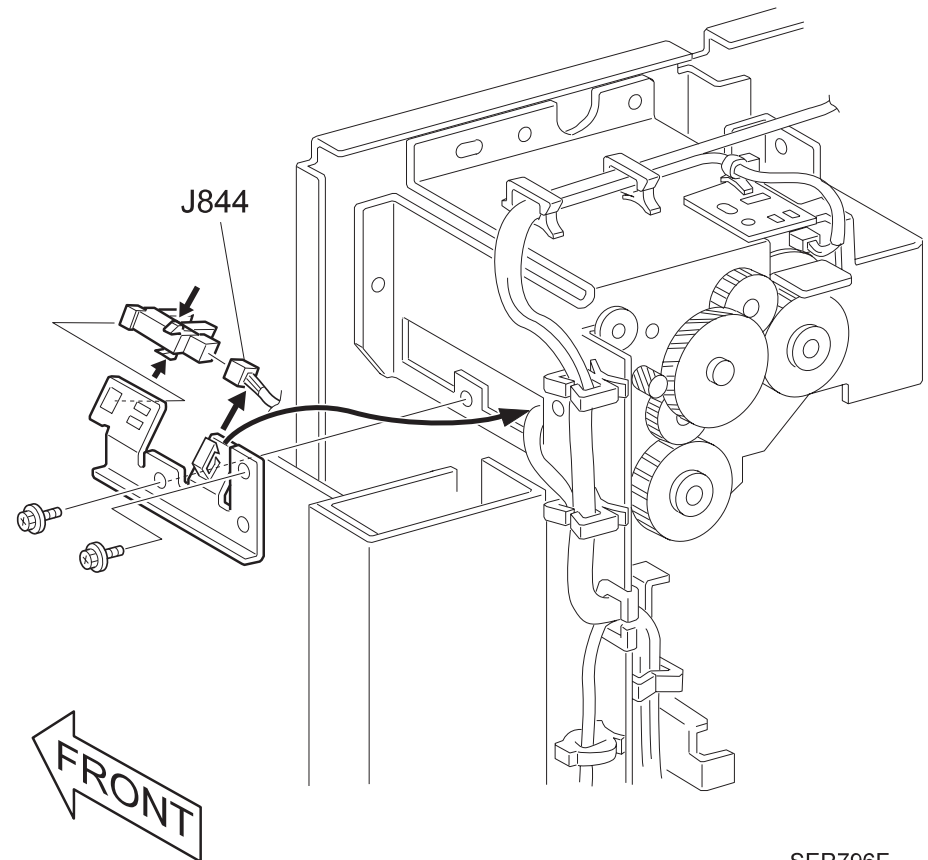

Figure 3-87. Offset Home Sensor

SER796F

### 3.4.79 Finisher Stapler PWB Assembly

Refer to the exploded diagram (Figure 4-44, "Electrical Module" on page 191).

#### 3.4.79.1 Removal



**Before removing the Finisher Stapler PWB, be sure to cut the AC inlet power supply to the HCS.**

1. Remove the HCS from the printer. (Refer to "Finisher Stapler" on page 35)
2. Remove the Finisher Stapler PWB Cover and the Connector Cover. (Refer to "Finisher Stapler PWB Cover and Connector Cover" on page 48)
3. Loosen one screw of the PWB Top Cover, which is at the center of the upper edge.

**NOTE:** Do not remove.

4. Remove eleven screws securing the PWB Top Cover to the PWB Bracket.
5. Lift the PWB Top Cover and remove it from the Bracket.
6. Pull out twelve connectors which is connected to the Finisher Stapler PWB.
7. Remove eight screws securing the Finisher Stapler PWB to the PWB Bracket and remove the Finisher Stapler PWB from the Bracket.

#### 3.4.79.2 Installation

1. Place the Finisher Stapler PWB to the PWB Bracket as shown in the Figure 3-88.
2. Secure the Finisher Stapler PWB to the PWB Bracket without screws.
3. Connect twelve screws to the Finisher Stapler PWB.
4. Hang the key-shaped hole at the center of the upper edge of the PWB Top Cover on the loosen screw of the PWB Bracket

5. Secure the PWB Top Cover to the PWB Bracket with eleven screws.
6. Tighten the central screw at the upper edge of the PWB Top Cover.
7. Install the Finisher Stapler PWB Cover and the Connector Cover. (Refer to "Finisher Stapler PWB Cover and Connector Cover" on page 48)
8. Install the HCS to the printer. (Refer to "Finisher Stapler" on page 35)

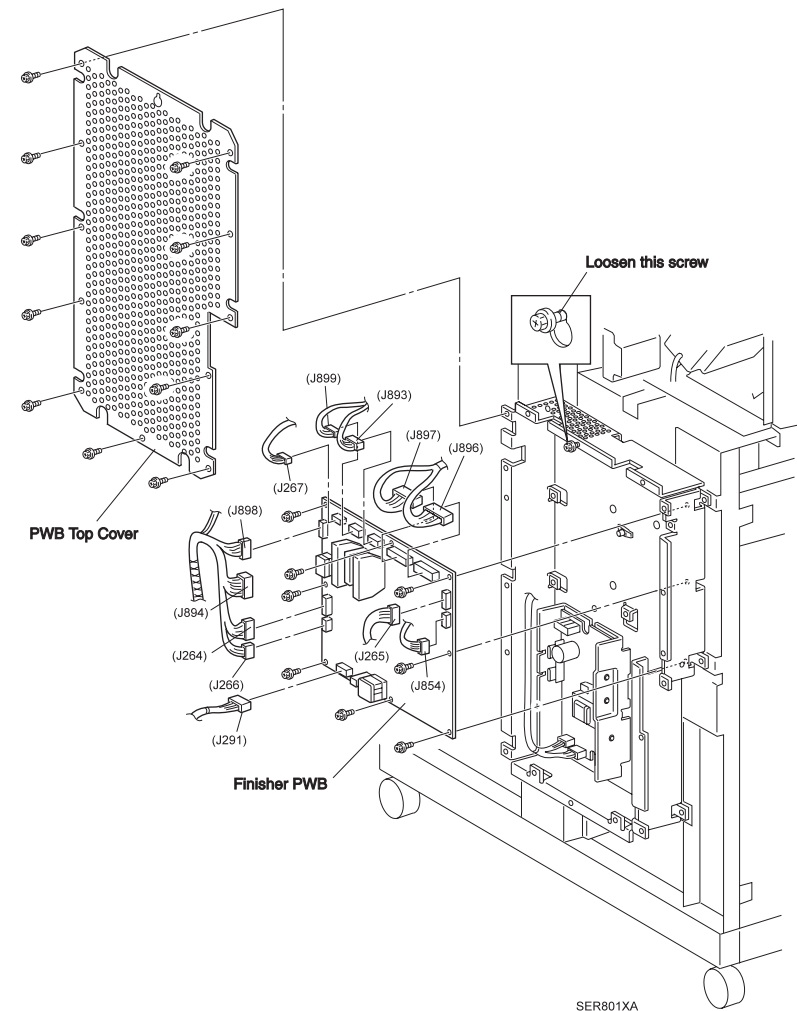

Figure 3-88. Finisher Stapler PWB Assembly

### 3.4.80 LVPS (OP11/OPR4H)

Refer to the exploded diagram (Figure 4-44, "Electrical Module" on page 191).

#### 3.4.80.1 Removal



**Before removing the Finisher Stapler PWB, be sure to cut the AC inlet power supply to the HCS.**

1. Remove the HCS from the printer. (Refer to "Finisher Stapler" on page 35)
2. Remove the Finisher Stapler PWB Cover and the Connector Cover. (Refer to "Finisher Stapler PWB Cover and Connector Cover" on page 48)
3. Loosen one screw of the PWB Top Cover, which is at the center of the upper edge.

**NOTE:** Do not remove.

4. Remove eleven screws securing the PWB Top Cover to the PWB Bracket.
5. Lift the PWB Top Cover and remove it from the Bracket.
6. Pull out J2, J502, J505 from the LVPS PWB.
7. Remove two screws securing the LVPS PWB to the PWB Bracket and remove the LVPS PWB from the Bracket.

#### 3.4.80.2 Installation

1. Place the LVPS PWB to the PWB Bracket as shown in the Figure 3-88.
2. Secure the LVPS PWB to the PWB Bracket with two screws (at its upper and bottom end).
3. Connect J2, J502, J505 to the LVPS PWB.
4. Hang the key-shaped hole at the center of the upper edge of the PWB Top Cover on the loosen screw of the PWB Bracket
5. Secure the PWB Top Cover to the PWB Bracket with eleven screws.

6. Tighten the central screw at the upper edge of the PWB Top Cover.
7. Install the Finisher Stapler PWB Cover and the Connector Cover. (Refer to "Finisher Stapler PWB Cover and Connector Cover" on page 48)
8. Install the HCS to the printer. (Refer to "Finisher Stapler" on page 35)

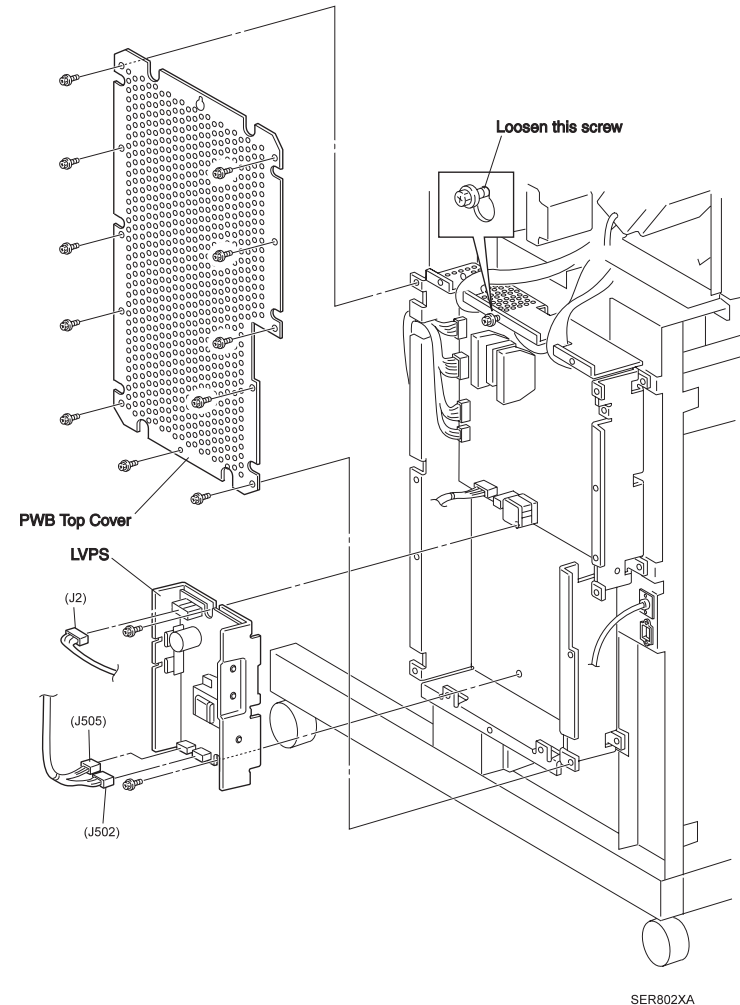

**Figure 3-89. LVPS (OP11/OPR4H)**

### 3.4.81 DOC Cover Assembly

Refer to the exploded diagram (Figure 4-46, "HCS DOC" on page 193).

#### 3.4.81.1 Removal

1. Remove the HCS from the printer. (Refer to "Finisher Stapler" on page 35)
2. Lift the DOC HCS and remove it from the Fuser.
3. Lay DOC HCS upside down on the flat space.
4. Remove three screws securing the IN Gate Support to the DOC Cover and remove the Support from the Cover.

#### 3.4.81.2 Installation

1. Lay DOC HCS upside down on the flat space.
2. Install the IN Gate Support against the DOC Cover as shown in the Figure 3-90.
3. Adjust the position of the IN Gate Support as its two position marking holes matches the two position marking tabs on the DOC Cover.
4. Secure the IN Gate Support to the DOC Cover with three screws.
5. Install the DOC HCS to the Fuser.
6. Install the HCS to the printer. (Refer to "Finisher Stapler" on page 35)

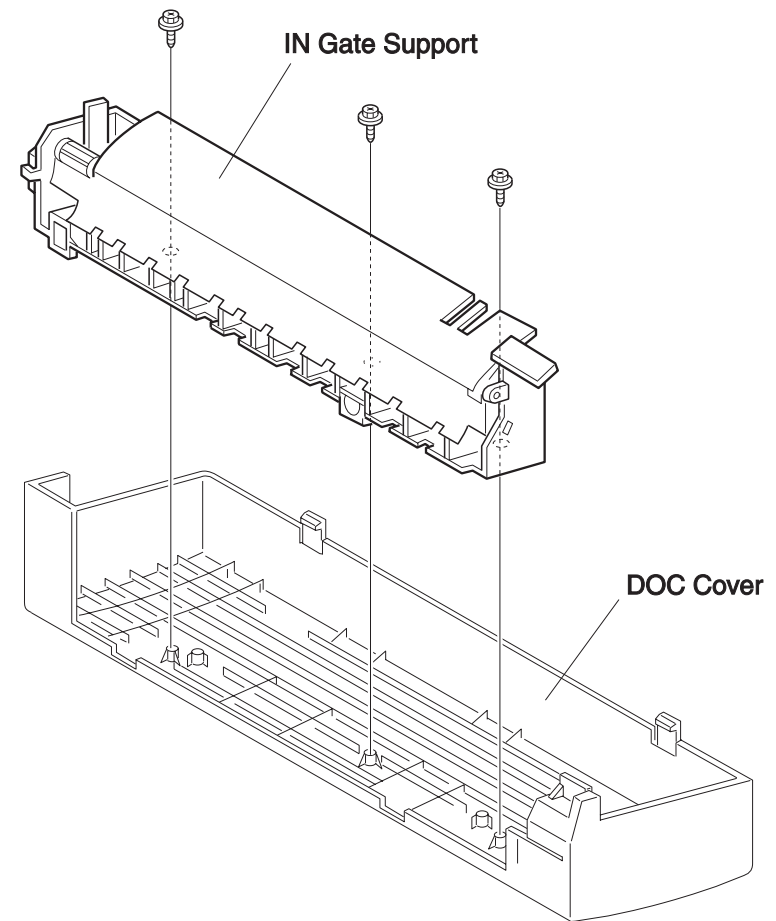

SER732XA

**Figure 3-90. DOC Cover Assembly**

### 3.4.82 IN Gate Support Assembly

Refer to the exploded diagram (Figure 4-46, "HCS DOC" on page 193).

#### 3.4.82.1 Removal

1. Remove the HCS from the printer. (Refer to "Finisher Stapler" on page 35)
2. Lift the DOC HCS and remove it from the Fuser.
3. Lay DOC HCS upside down on the flat space.
4. Remove three screws securing the IN Gate Support to the DOC Cover and remove the Support from the Cover.

#### 3.4.82.2 Installation

1. Lay DOC HCS upside down on the flat space.
2. Install the IN Gate Support against the DOC Cover as shown in the Figure 3-91.
3. Adjust the position of the IN Gate Support as its two position marking holes matches the two position marking tabs on the DOC Cover.
4. Secure the IN Gate Support to the DOC Cover with three screws.
5. Install the DOC HCS to the Fuser.
6. Install the HCS to the printer. (Refer to "Finisher Stapler" on page 35)

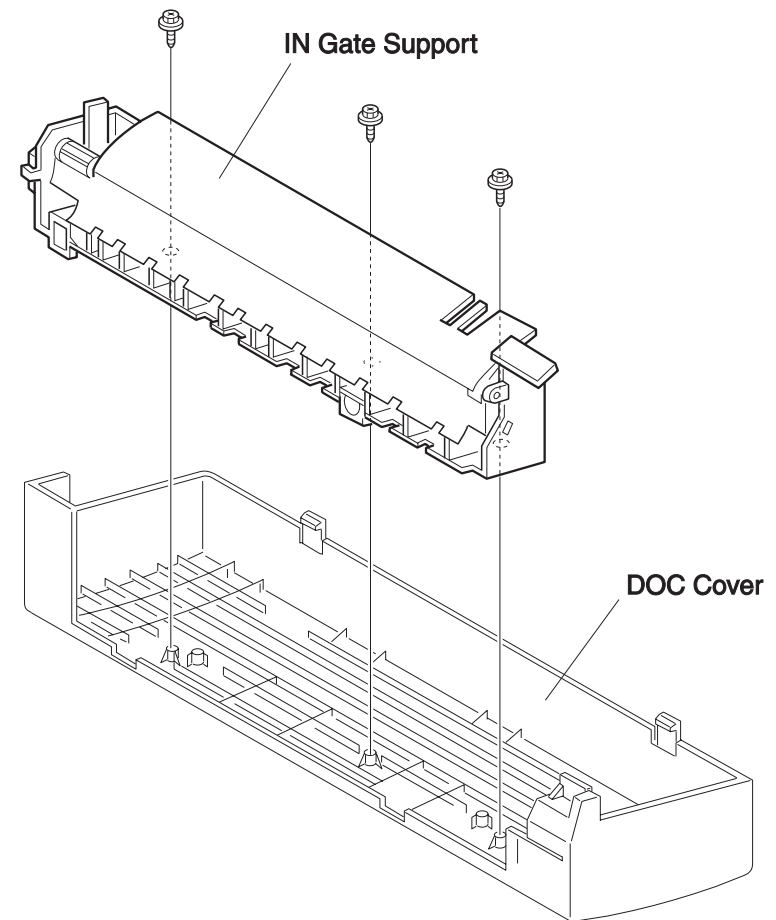

SER732XA

Figure 3-91. IN Gate Support Assembly



### 3.4.83 IN Gate Support Actuator

Refer to the exploded diagram (Figure 4-46, "HCS DOC" on page 193).

#### 3.4.83.1 Removal

1. Remove the IN Gate Support Assembly. (Refer to "IN Gate Support Assembly" on page 128)
2. Open the latches of the Actuator and pull out the Actuator from the Shaft.

#### 3.4.83.2 Installation

1. Place the IN Gate Actuator as shown in the Figure 3-92.
2. Push in the IN Gate Actuator to the Shaft until the latches snaps.
3. Install the IN Gate Support Assembly. (Refer to "IN Gate Support Assembly" on page 128)

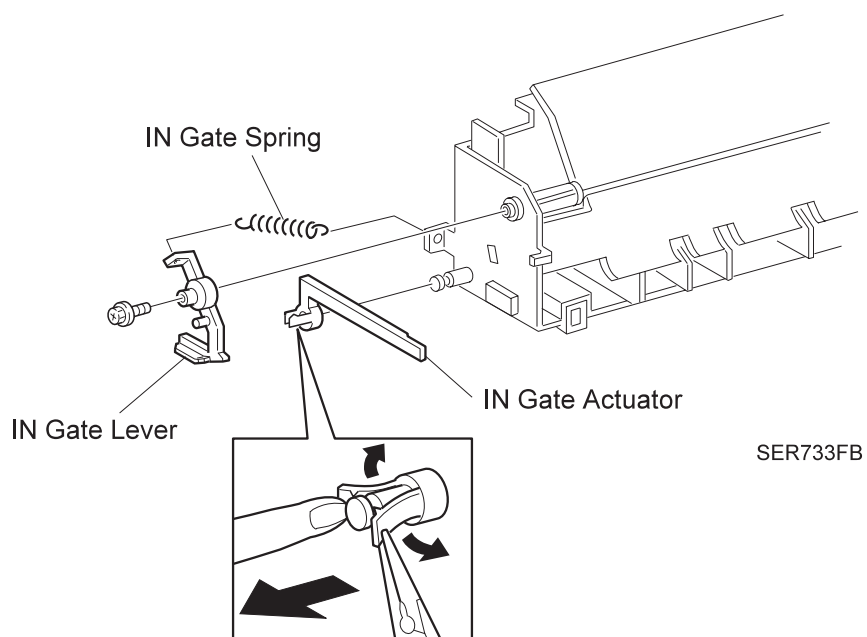

Figure 3-92. IN Gate Support Assembly

### 3.4.84 Transport Assembly

Refer to the exploded diagram (Figure 4-24, "HCS Transport" on page 165).

#### 3.4.84.1 Removal

1. Remove the HCS from the printer. (Refer to "Finisher Stapler" on page 35)
2. Remove two screws securing the Transport Rear Cover to the Transport Assembly and remove the Cover.
3. Pull out J256, J262A, J263A, and J268A.
4. Lock two Support Arms under the Transport Assembly and lower the Assembly.
5. Pull out two K Clips from the Pivot Shafts at the front and the rear of the Transport Assembly.
6. Shift the Transport Assembly to the left and remove the front Pivot Shaft and remove the front side of the Assembly from the HCS frame.
7. Shift the Transport Assembly to the right and remove the rear Pivot Shaft and remove the Assembly.

#### 3.4.84.2 Installation

1. Lock two Support Arms under the Transport Assembly.
2. Place the Transport Assembly vertically as shown in the Figure 3-93.
3. Insert the rear Pivot Shaft of the Transport Assembly to the rear hole of the Transport Bracket.
4. Insert the front Pivot Shaft of the Transport Assembly to the front hole of the Transport Bracket.
5. Set two K Clips in and secure the front and rear Pivot Shaft.
6. Lift the Transport Assembly and place it horizontally. Lower two Support Arms under the Assembly and lock them.
7. Connect J256M, J262A, J263A, and J268A.
8. Place the Transport Rear Cover against the Transport Assembly as shown in the Figure 3-93 and secure it with two screws.

9. Install the HCS to the printer. (Refer to "Finisher Stapler" on page 35)

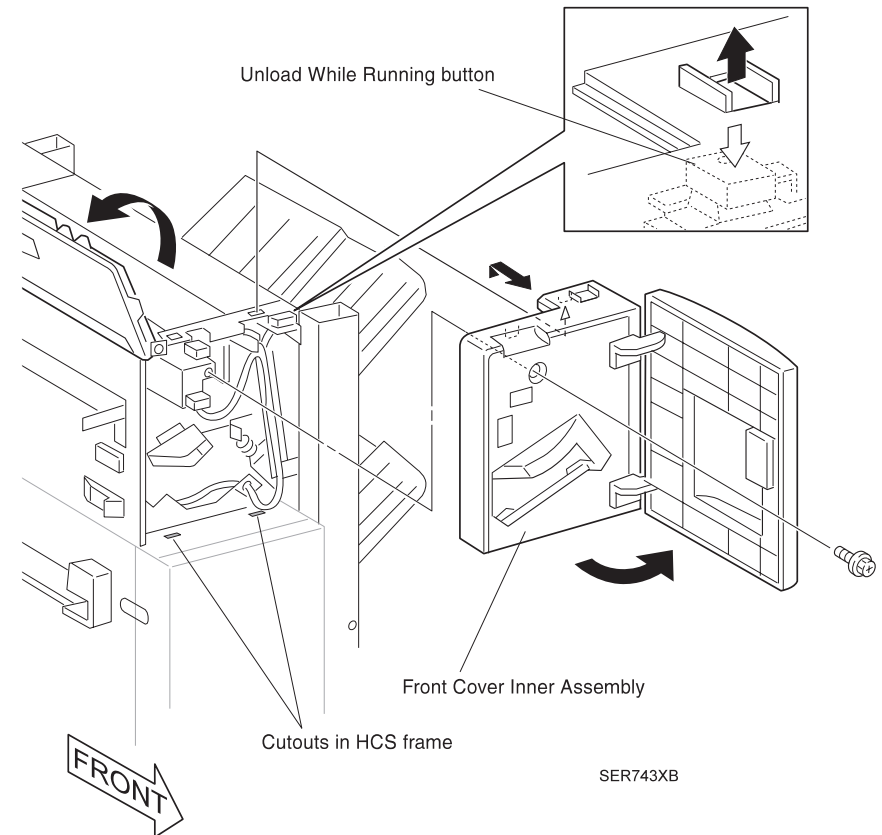

**Figure 3-93. Transport Assembly**

### 3.4.85 Transport Assembly Drive Belt

Refer to the exploded diagram (Figure 4-47, "Frame Transport, Rear" on page 194).

#### 3.4.85.1 Removal

1. Remove the Transport Assembly. (Refer to "Transport Assembly" on page 130)
2. Remove the Tension Spring. (Figure 1)
3. Pull out J260 from the IN Gate Interlock Sensor.
4. Remove the wire harness from the harness clip on the Bracket Assembly.
5. Remove two screws securing the IN Gate Solenoid Assembly to the Bracket Assembly and remove the Solenoid Assembly.
6. Remove one screw securing the Ground Wire to the Bracket Assembly and remove the Ground Wire.
7. Remove two screws securing the Bracket Assembly to the Transport Assembly and remove the Bracket Assembly from the frame.
8. Remove two screws securing the Tension Bracket to the Transport Frame and remove the Bracket. (Figure 2)
9. Remove the Idler Gear Spring from the Transport Frame.
10. Remove E ring binding the Idler Gear Support to the Frame and remove the Support.
11. Remove E ring binding the Idler Gear to the Frame and remove the Idler Gear.
12. Remove the Transport Assembly Drive Belt.

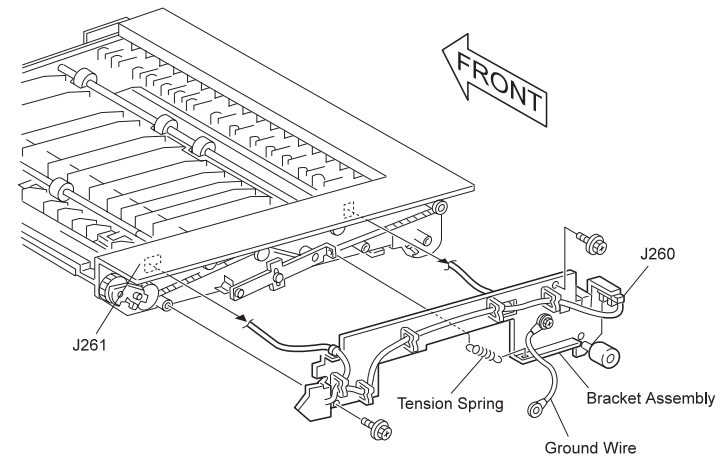

Figure 1

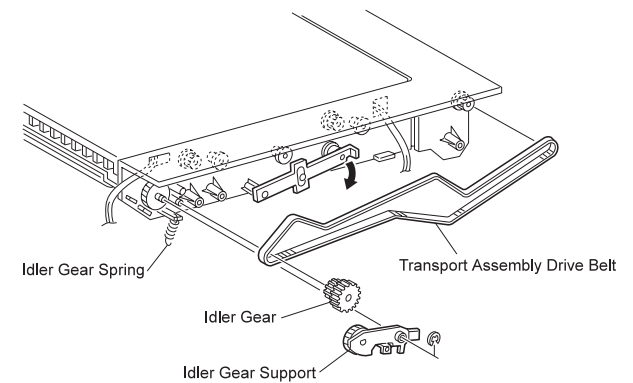

Figure 2

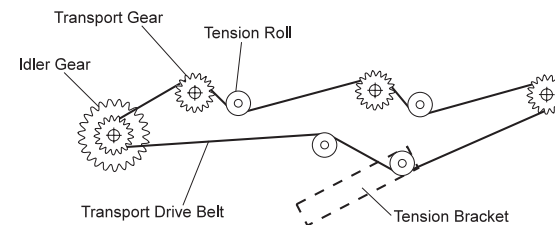

Figure 3

SER740XC

Figure 3-94. Transport Assembly Drive Belt

### 3.4.85.2 Installation

1. Prepare the Transport Assembly Drive Belt as the flat part faces out.
2. Hang the Transport Assembly Drive Belt to the Shaft of the Idler Gear.
3. Install the Idler Gear as the Drive Belt goes through the rear of the Idler Gear.
4. Bind the Idler Gear with E ring.
5. Let the Drive Belt on the Transport Gear and the Idler Gear as shown in the figure 3.
6. Install the Idler Gear Support and bind the Frame with E ring.
7. Hang the Idler Gear Spring to the Transport Frame.
8. Install the Tension Bracket to the Transport Frame. Hand the Tension Roll to the rough part (inside) of the Belt as shown in the figure 3.
9. Secure the Tension Bracket to the Frame with two screws.
10. Install the Bracket Assembly to the Transport Frame and secure the Bracket with two screws.
11. Install the IN Gaye Solenoid Assembly to the Bracket Assembly and secure the Solenoid to the Bracket with two screws.
12. Install the Ground wire to the Bracket Assembly and secure the wire with one screw.
13. Ensure J261 is connected to the Transport Interlock Sensor.
14. Let the wire harness under the wire clip on the Bracket Assembly.
15. Connect J260 to the IN Gate Interlock Sensor.
16. Hang the Tension Spring on the Tension Bracket.
17. Install the Transport Assembly. (Refer to "Transport Assembly" on page 130)

### 3.4.86 IN Gate Interlock Switch

Refer to the exploded diagram (Figure 4-47, "Frame Transport, Rear" on page 194).

#### 3.4.86.1 Removal

1. Remove the Transport Assembly. (Refer to "Transport Assembly" on page 130)
2. Pull out J260 from the IN Gate Interlock Switch.
3. Release the latches at the rear of the IN Gate Interlock Switch and remove the Switch from the Bracket Assembly.

#### 3.4.86.2 Installation

1. Place the IN Gate Interlock Switch as shown in the Figure 3-95.
2. Insert the latches of the Switch to the hole of the Bracket Assembly.

**NOTE:** Switch snaps.

3. Connect J260 to the Switch.
4. Install the Transport Assembly. (Refer to "Transport Assembly" on page 130)

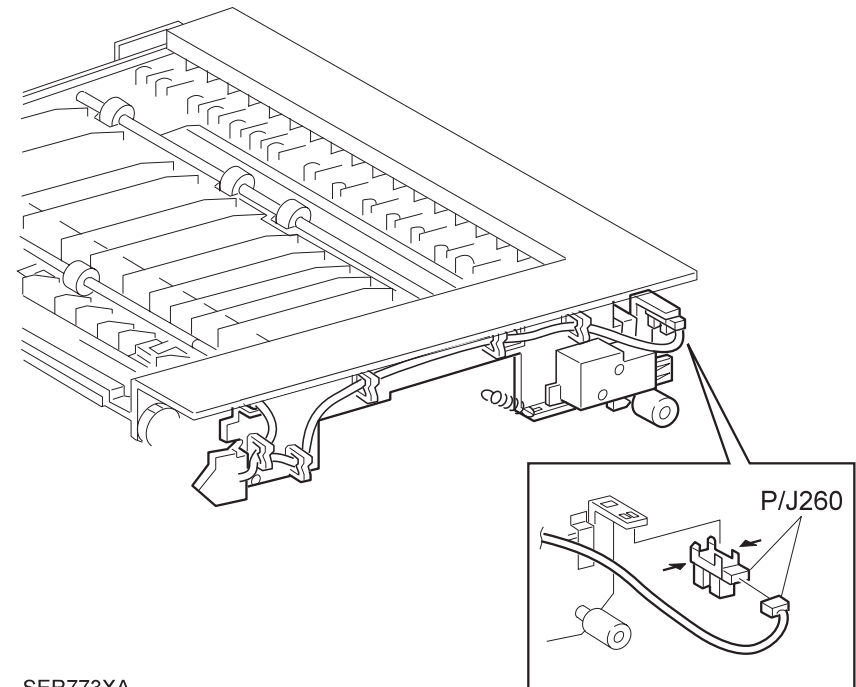

SER773XA

**Figure 3-95. IN Gate Interlock Switch**

### 3.4.87 IN Gate Solenoid Assembly

Refer to the exploded diagram (Figure 4-47, "Frame Transport, Rear" on page 194).

#### 3.4.87.1 Removal

1. Remove the Transport Assembly. (Refer to "Transport Assembly" on page 130)
2. Remove the wire harness (P256M) of the Solenoid from the wire clip.
3. Remove one screw securing the Ground Wire to the Solenoid Assembly.
4. Remove two screws securing the Solenoid Assembly to the Bracket and remove the Solenoid Assembly.
5. Pull out the Damper Bracket from the Solenoid Assembly.
6. Remove two screws securing the Solenoid Cover to the Solenoid.



**Solenoid Plunger is pushed by the Spring. When the Solenoid is removed from the Solenoid Cover, the Plunger will jump out.**

#### 3.4.87.2 Installation

1. Ensure the Solenoid Spring and Link Assembly is installed to the Solenoid Plunger correctly.
2. Insert the IN Gate Solenoid to the Solenoid Cover and hang the hole of the Link Assembly to the projection of the Cover.
3. Secure the Solenoid Cover to the Solenoid with two screws.
4. Insert the Damper Bracket to the Solenoid Cover with the form rubber toward the Solenoid coil.
5. Hang the projection on the Cover to the hole of the Bracket and push in the Solenoid Assembly and match two screw threaded holes.
6. Secure the Solenoid Assembly to the Bracket with two screws.

7. Install the Ground Wire to the Solenoid Assembly and secure the wire one screw.
8. Reinstall the Ground Wire to the Solenoid Assembly and use one screw to secure the wire.
9. Place the wire according to the distribution board and put the wire under the harness clip on the Bracket.
10. Install the Transport Assembly. (Refer to "Transport Assembly" on page 130)

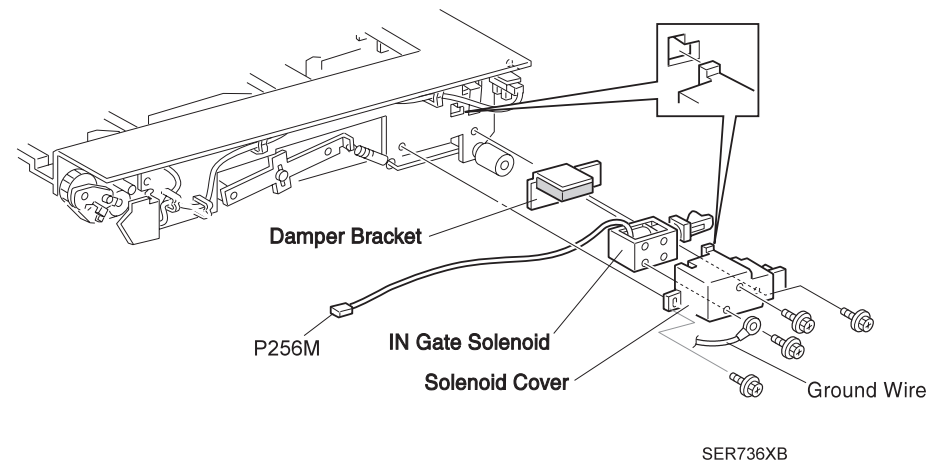

**Figure 3-96. IN Gate Solenoid Assembly**

### 3.4.88 Roller Unit

Refer to the exploded diagram (Figure 4-47, "Frame Transport, Rear" on page 194).

#### 3.4.88.1 Removal

1. Remove the Transport Assembly. (Refer to "Transport Assembly" on page 130)
2. Remove the Roller Unit from the Shaft of the Bracket Assembly.

#### 3.4.88.2 Installation

1. Place the Roller Unit as the flat side of the Roller faces the opposite of the Bracket.
2. Install the Roller to the Shaft of the Bracket Assembly.
3. Install the Transport Assembly. (Refer to "Transport Assembly" on page 130)

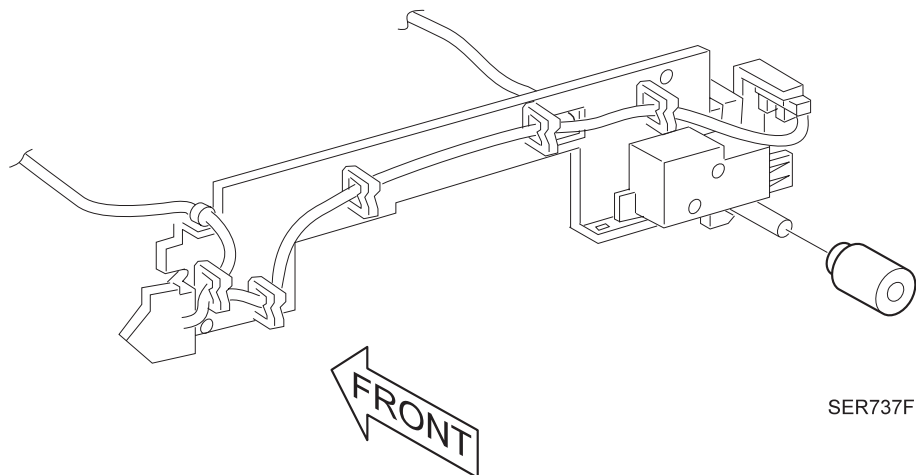

Figure 3-97. Roller Unit

### 3.4.89 Transport Cover Assembly

Refer to the exploded diagram (Figure 4-48, "Frame Transport, Open" on page 195).

#### 3.4.89.1 Removal

1. Remove the Transport Assembly. (Refer to "Transport Assembly" on page 130)
2. Open the Transport.
3. Remove the screw securing the Cover Support Strap to the Transport.
4. Carefully break remove the rear Pivot hole of the Cover from the Pivot axis of the Transport with the slotted screwdriver. (Refer to step 2 of the Figure 3-98)
5. Remove the Transport Cover Assembly.

#### 3.4.89.2 Installation

1. Insert the front Pivot of the Cover to the front Pivot hole of the Transport. (Refer to step 1 of the Figure 3-98)
2. Insert the rear Pivot of the Cover to the rear Pivot hole of the Transport with the slotted screwdriver. (Refer to step 2 of the Figure 3-98)
3. Install the Cover Support Strap to the Transport with one screw.
4. Install the Transport Assembly. (Refer to "Transport Assembly" on page 130)

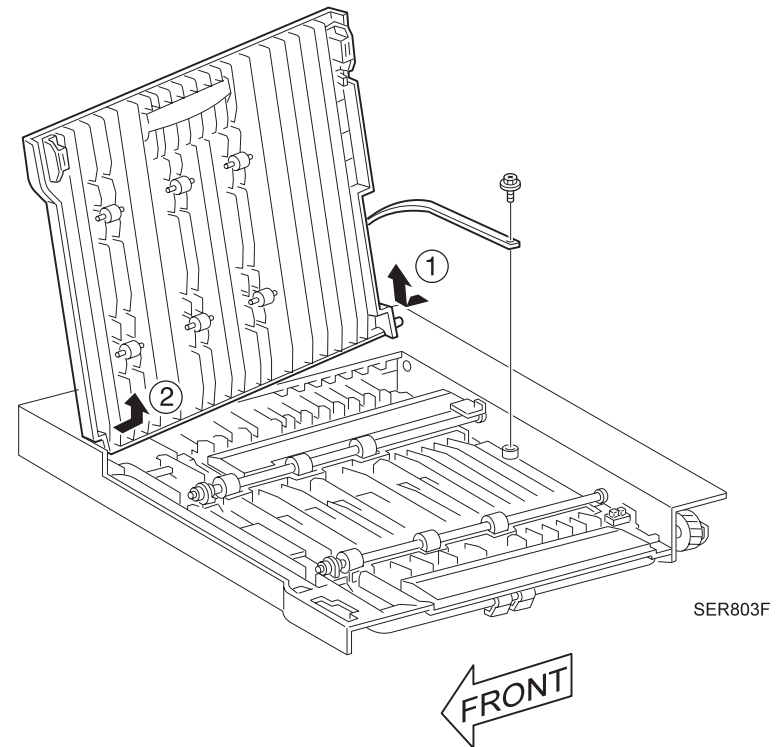

**Figure 3-98. Transport Cover Assembly**



### 3.4.90 Transport Interlock Sensor

Refer to the exploded diagram (Figure 4-48, "Frame Transport, Open" on page 195).

#### 3.4.90.1 Removal

1. Open the Transport Cover.
2. Release two latches, which secures the Transport Exit Sensor to the Transport and remove the Transport Exit Sensor Cover carefully with force.
3. Remove the wire from the wire clip on the Transport Interlock Sensor.
4. Remove two screws securing the Transport Interlock Sensor Plate to the Transport and remove it along with the sensor.
5. Pull out J261 from the Sensor.
6. Release the latches, which secures Sensor to the Plate, and remove the Sensor.

#### 3.4.90.2 Installation

1. Place the Transport Interlock Sensor against the Sensor Plate as shown in the Figure 3-99.
2. Insert the rear latches of the Sensor to the hole of the Plate.
3. Connect J261 to the Sensor.
4. Install the Sensor Plate to the Transport as the position marking projection of the Transport goes into the position marking hole of the Plate.
5. Secure the Plate to the Transport with one screw.
6. Connect J261 to the Sensor.
7. Hang the wire on the wire clip on the Plate.
8. Install the Transport Exit Sensor Cover to the Transport. First, insert two latches of the Cover to the latch holes on the Transport, and then push the Cover in.
9. Close the Transport Cover.

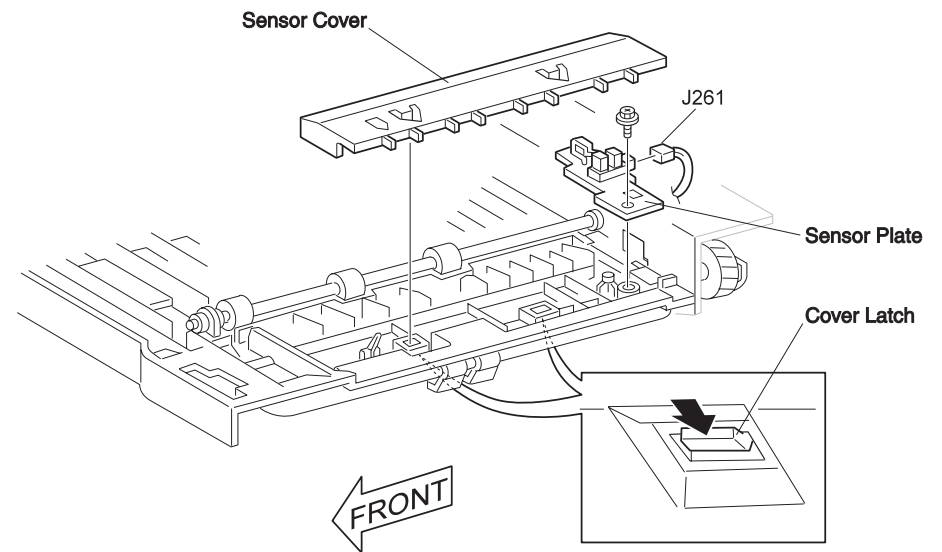

SER809XA

Figure 3-99. Transport Interlock Sensor

### 3.4.91 Transport Roll

Refer to the exploded diagram (Figure 4-48, "Frame Transport, Open" on page 195).

#### 3.4.91.1 Removal

1. Remove the Transport Assembly. (Refer to "Transport Assembly" on page 130)
2. Remove the wire harness from the wire clip on the Bracket Assembly.
3. Remove the Tension Spring from the Bracket Assembly.
4. Remove the IN Gate Solenoid Assembly. (Refer to "IN Gate Solenoid Assembly" on page 134)
5. Remove two screws securing the Bracket Assembly to the Transport Frame and remove the Bracket from the Frame and make the gap that enables the access to the Transport Gear.

**NOTE:** One of two screws secures Ground Wire to the Bracket.

6. Remove the E ring securing the Transport Gear to the Transport Frame and remove the Transport Gear.
7. Open the Transport Cover.
8. Set three latches off, which secures Transport Roll Guide to the Transport and carefully remove the Transport Roll Guide with force.
9. Remove E ring binding each end of Transport Roll and remove the Roll and Bearing.

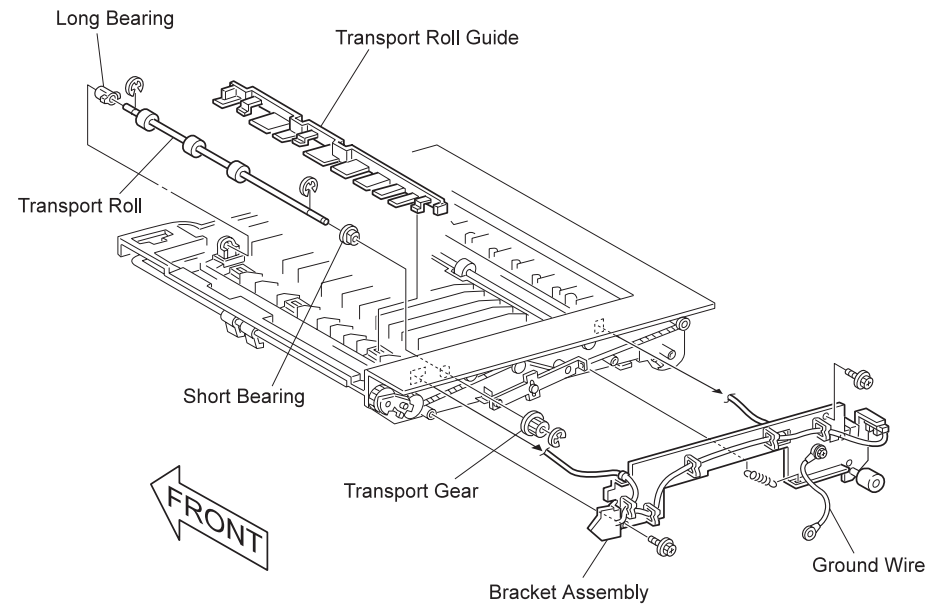

**Figure 3-100. Transport Roll**

#### 3.4.91.2 Installation

1. Put the Bearing on each end of the Transport Roll.
2. Insert the rear end of the Shaft of the Transport Roll to the rear bearing hole of the Transport Frame.
3. Insert the front end of the Shaft of the Transport Roll to the front bearing hole of the Transport Frame.
4. Insert the front and rear Bearings to the respective bearing holes.
5. Put the E ring on each end of the Shaft and secure the Shaft to the Bearing.
6. Install the Transport Roll Guide to the Transport. First, insert three latches into the latch hole of the Transport and push the Guide in.
7. Install the Transport Gear to the Shaft of the Transport Roll.

8. Secure the Gear to the Shaft with E ring.
9. Ensure the Transport Drive Belt goes through the upper side of the Gear.  
(For the right position of the Drive Belt, refer to "Transport Assembly Drive Belt" on page 131)
10. Install the Bracket Assembly to the Transport Frame.
11. Secure the Ground Wire with one screw as shown in the Figure 3-100.

**NOTE:** *This screw also secures the Bracket Assembly to the Transport Frame.*

12. Secure the Bracket Assembly to the Transport Frame with another screw.
13. Install the IN Gate Solenoid Assembly. (Refer to "IN Gate Solenoid Assembly" on page 134)
14. Hang the Tension Spring on the Bracket Assembly.
15. Ensure J261 is connected to the Transport Interlock Sensor.
16. Put the wire harness under the harness clip on the Bracket Assembly.
17. Install the Transport Assembly. (Refer to "Transport Assembly" on page 130)

### 3.4.92 Transport Entrance Sensor

Refer to the exploded diagram (Figure 4-48, "Frame Transport, Open" on page 195).

#### 3.4.92.1 Removal

1. Open the Transport Cover.
2. Release two latches, which secures the Transport Entrance Sensor Cover to the Transport and remove the Cover carefully with force.
3. Remove one screw securing the Transport Entrance Sensor Plate to the Transport and remove the Plate along with the Sensor.
4. Pull out J275M from the Sensor.
5. Release the latches, which secures the Sensor to the Plate, and remove the Sensor from the Plate.

#### 3.4.92.2 Installation

1. Install the Transport Entrance Sensor to the Sensor Plate toward the direction shown in the Figure 3-101.
2. Insert the rear latches off the Sensor to the hole of the Plate.
3. Connect J275M to the Sensor.
4. Install the Sensor Plate to the Transport.

**NOTE:** Ensure the Actuator of the Sensor is not broken.

5. Secure the Plate to the Transport with one screw.
6. Install the Transport Entrance Sensor Cover. First, insert two latches to the latch hole of the Transport and then push the Cover in.
7. Close the Transport Cover.

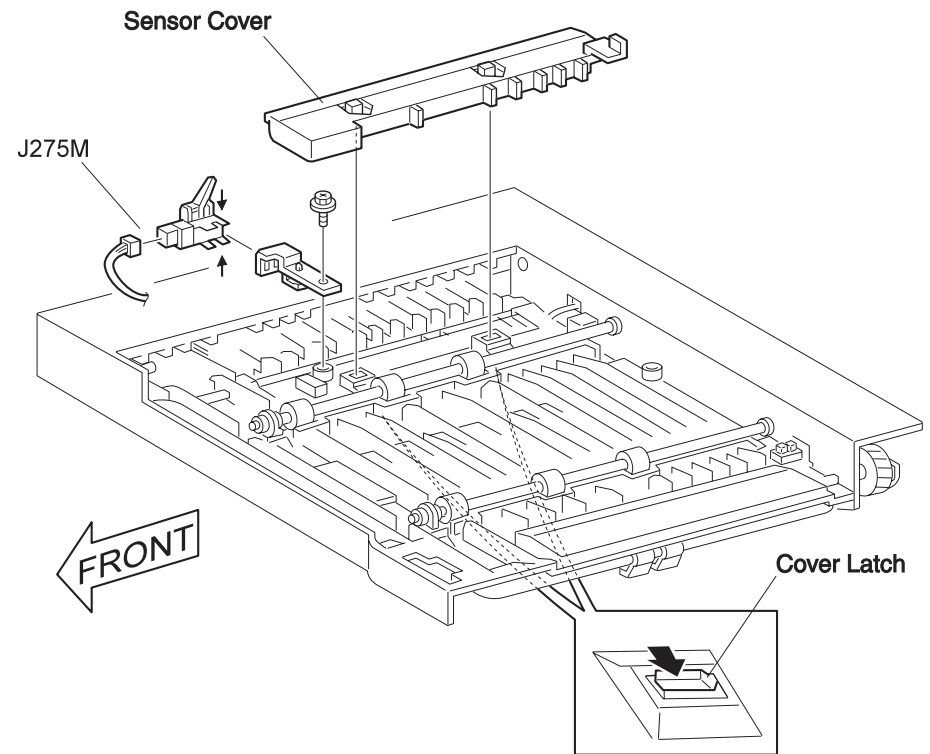

SER741XA

**Figure 3-101. Transport Entrance Sensor**

### 3.4.93 IOT Paper Full Sensor

Refer to the exploded diagram (Figure 4-48, "Frame Transport, Open" on page 195).

#### 3.4.93.1 Removal

1. Remove the HCS from the printer. (Refer to "Finisher Stapler" on page 35)
2. Open the Transport Cover.
3. Release two latches, which secures the Transport Entrance Sensor Cover to the Transport and remove the Cover carefully with force.
4. Pull out J259 from the IOT Paper Full Sensor.
5. Release the latches, which secures the IOT Paper Full Sensor to the Transport. Push down the Sensor over the Transport and remove the Sensor from the Transport.

#### 3.4.93.2 Installation

1. Install the IOT Paper Full Sensor to the bottom of the Transport Assembly toward the direction shown in the Figure 3-101.
2. Connect J259 to the Sensor.
3. Install the IOT Paper Full Sensor to the Transport. First, insert two latches to the latch hole of the Transport and then push the Cover down.
4. Close the Transport Cover.
5. Install the HCS to the printer. (Refer to "Finisher Stapler" on page 35)

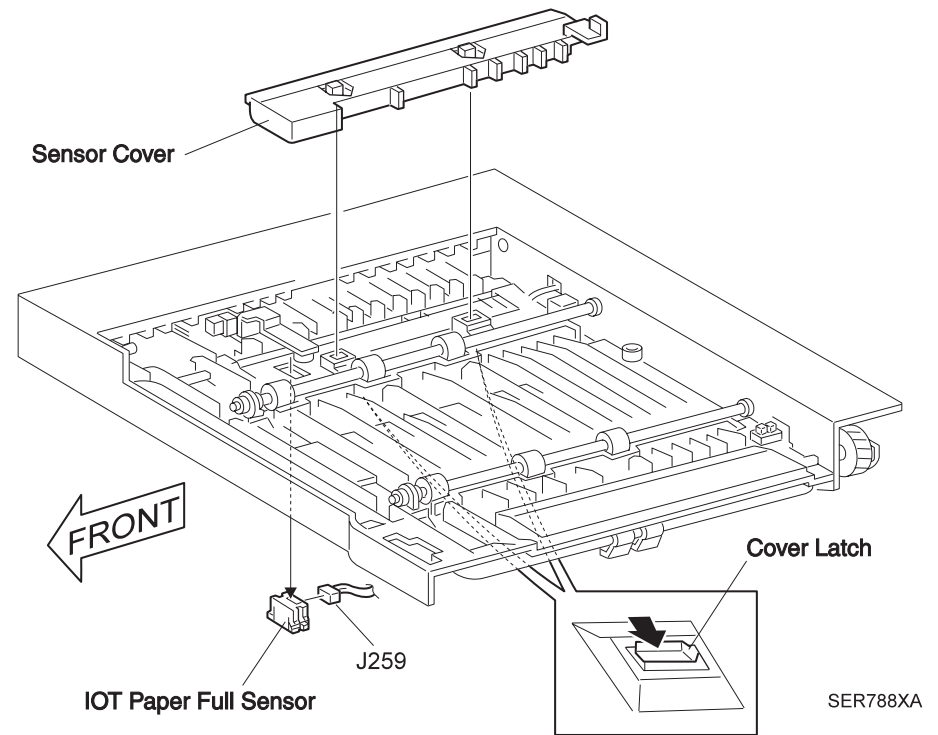

Figure 3-102. IOT Paper Full Sensor

### 3.4.94 Transport Exit Sensor

Refer to the exploded diagram (Figure 4-48, "Frame Transport, Open" on page 195).

#### 3.4.94.1 Removal

1. Remove the HCS from the printer. (Refer to "Finisher Stapler" on page 35)
2. Open the Transport Cover.
3. Release two latches, which secure the Transport Exit Sensor Cover to the Transport and remove the Cover carefully with force.
4. Pull out J263 from the Transport Exit Sensor.
5. Release the latches, which secures the Transport Exit Sensor to the Transport and remove the Sensor from the Transport.

#### 3.4.94.2 Installation

1. Install the Transport Exit Sensor to the bottom of the Transport Assembly toward the direction shown in the Figure 3-101.
2. Connect J26359 to the Transport Exit Sensor.
3. Install the Transport Exit Sensor Cover to the Transport. First, insert two latches to the latch hole of the Transport and then push the Cover down.
4. Close the Transport Cover.
5. Install the HCS to the printer. (Refer to "Finisher Stapler" on page 35)

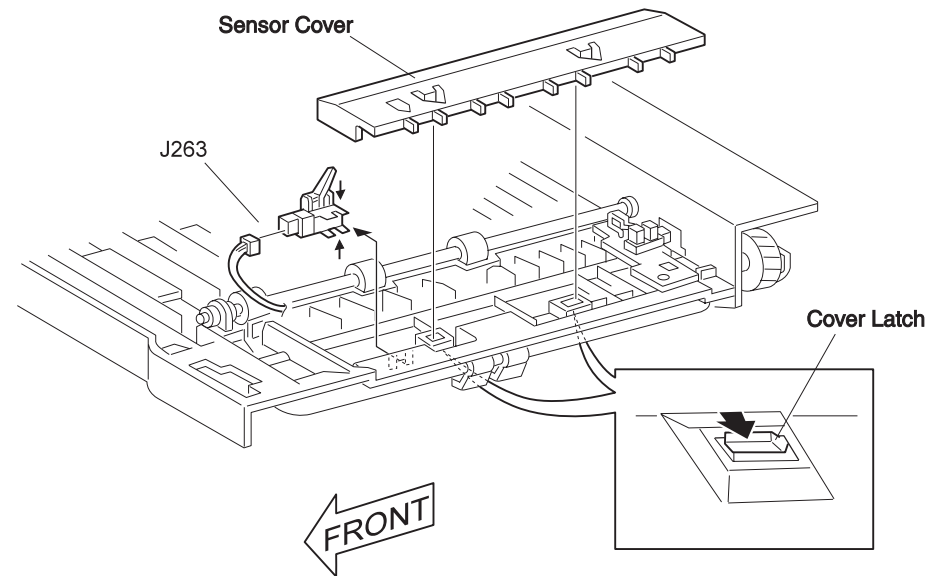

SER742XA

**Figure 3-103. Transport Exit Sensor**

**CHAPTER**

**4**

**APPENDIX**

### 4.1 Wiring Diagram and Signal Data

The following wiring diagrams show the electric connection inside the HCS (High Capacity Stacker).

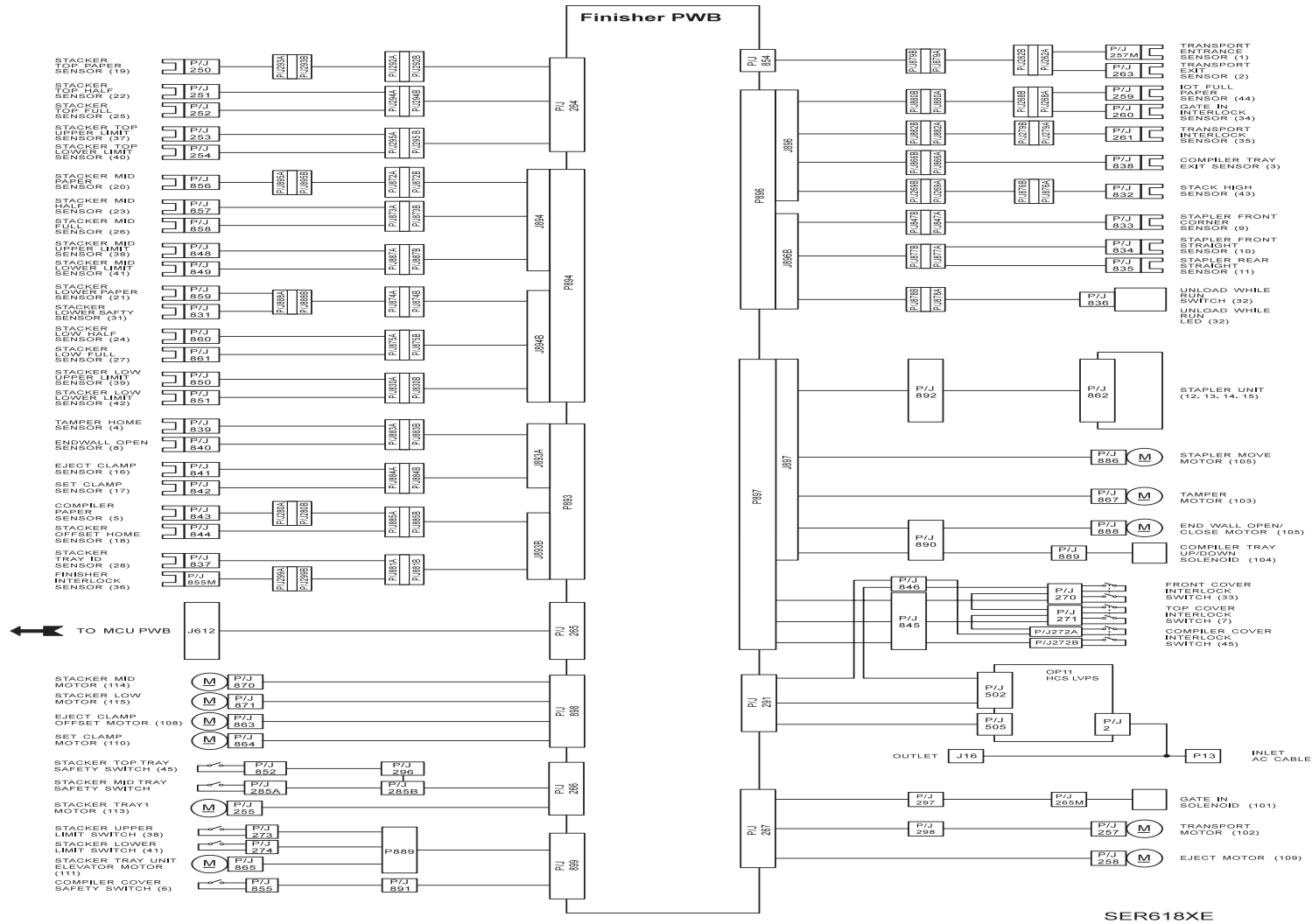

Figure 4-1. Whole Wiring Diagram



**STACKER TOP SENSORS ↔ FINISHER PWB**

The following tables show the signal names in the wiring diagram below.

Signal	Explanation
STACKER TOP PAPER SNR	Supervisory signal for paper on the Top Tray. High=There are paper on the Top Tray. Low=No paper.
STACKER TOP HALF SNR	Supervisory signal for paper level. High=The amount of paper is less than 50%. Low=The amount of paper is 50%.

Signal	Explanation
STACKER TOP FULL SNR	Supervisory signal for paper level. High=The amount of paper is less than 100%. Low=The amount of paper is 100% (Full).
STACKER UPPER LIMIT SNR	Supervisory signal for the upper limit. High=The amount of paper has reached the upper limit. Low=The amount of paper is within the upper limit.
STACKER LOWER LIMIT SNR	Supervisory signal for the lower limit. High=The amount of paper has reached the lower limit. Low=The amount of paper is over the lower limit.

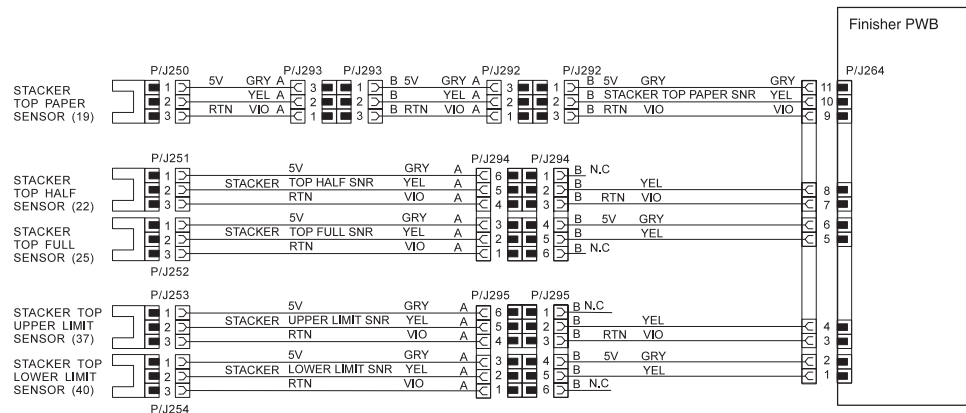

SER619XB

Figure 4-2. Wiring Diagram 1

**TRANSPORT ENTRANCE AND EXIT SENSORS ↔ FINISHER PWB**

The following tables show the signal names in the wiring diagram below.

Signal	Explanation
TRANSPORT ENT SNR	Supervisory signal for paper entering the Transport Assembly. High=There are paper entering. Low=No paper.
TRANSPORT EXIT SNR	Supervisory signal for paper exiting from the Transport Assembly. High=There are paper exiting. Low=No paper.

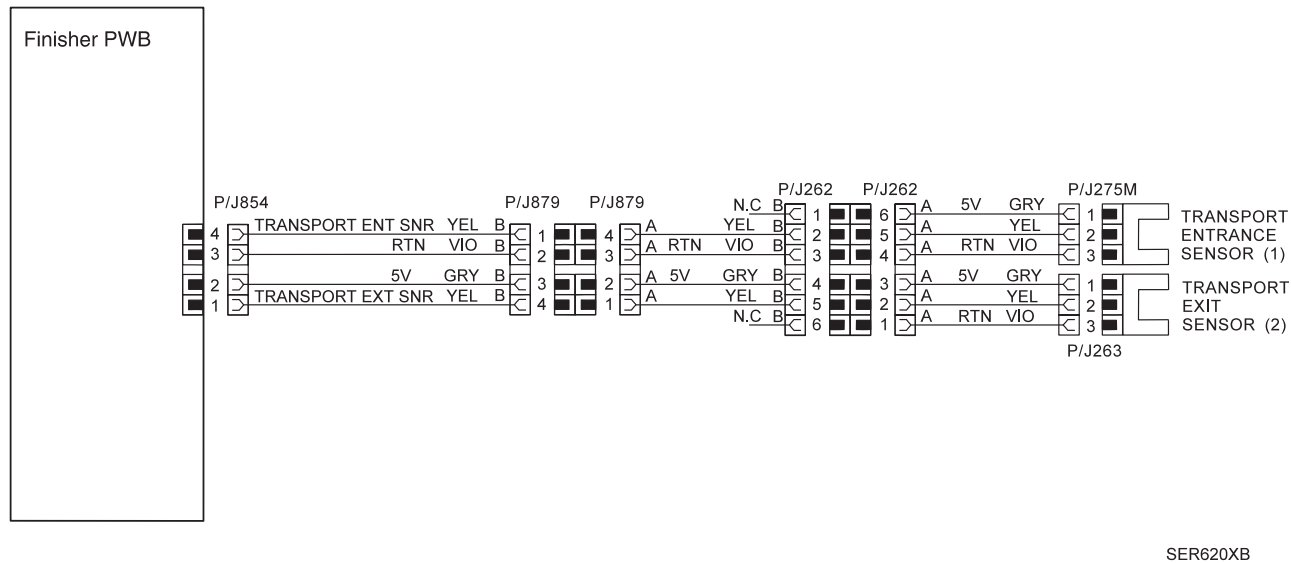

Figure 4-3. Wiring Diagram 2



COMPILER, INTERLOCK, STAPLER SENSORS ↔ FINISHER PWB

The following tables show the signal names in the wiring diagram below.

Signal	Explanation
IOT FULL PAPER SNR	Supervisory signal for paper on the Face Down Output Tray for Base Engine. High=Tray is full with paper. Low=Tray is not full with paper.
GATE IN INTLOCK SNR	Supervisory signal for the position of the Transport Assembly against the CCD Assembly. High=Sensor is not pushed in. (The Assembly is not in the right position.) Low=Sensor is pushed in.
TRANSPORT INTLOCK SNR	Supervisory signal for the Transport Cover. High=Cover is open. Low=Cover is closed.
COMPILER TRAY EXT SNR	Supervisory signal for paper exiting from the Compiler Tray. High=There are paper exiting from the Compiler Tray. Low=No paper exiting from the Compiler Tray
STACK HIGHT SNR	Supervisory signal for the paper height on the Tray 1/2/3. High=Sensor is not pushed in. (Sensor detected the paper height.) Low=Sensor is pushed in.
STAPLER F-CORNER SNR	Supervisory signal for stapler position of the front angle staple.. High=The stapler is on the right position. Low=The stapler is not on the right position.
STAPLER F-STRAIGHT SNF	Supervisory signal for stapler position of the front edge staple. High=The stapler is on the right position. Low=The stapler is not on the right position.

Signal	Explanation
STAPLER R-STRAIGHT SNF	Supervisory signal for stapler position of the rear edge staple. High=The stapler is on the right position. Low=The stapler is not on the right position.
UNLOAD W-RUN SW	Interrupt signal from the Unload While Running Switch to the Finisher PWB. High=Interruption occurred. Low=No interruption occurred.
UNLOAD W-RUN LED	Signal for the Switch on the Interlock LED. High=LED off. Low=LED on.

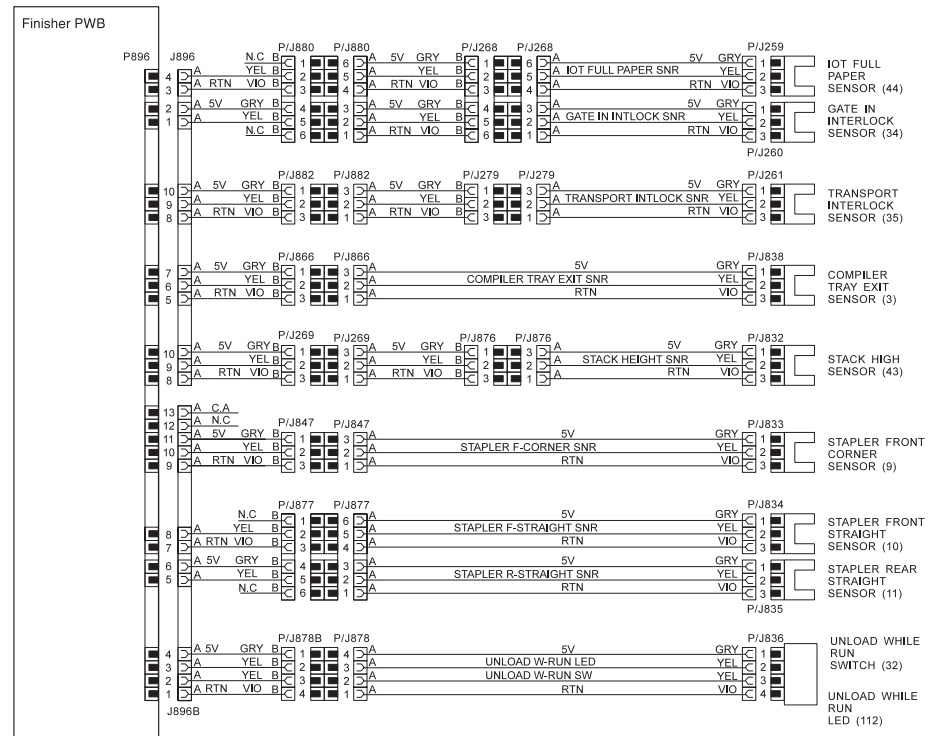

SER622XC

Figure 4-5. Wiring Diagram 4

TAMPER, INTERLOCK, STACKER SENSOR ↔ FINISHER PWB

The following tables show the signal names in the wiring diagram below.

Signal	Explanation
TAMPER HOME SNR	Supervisory signal for the Tamper position. High= Tamper is at the Home position. Low= Tamper is not at the Home position.
END WALL OPEN SNR	Supervisory signal for the Compiler END Wall position. High= The Compiler END Wall is at the upper position. Low= The Compiler END Wall is at the lower position.
EJECT CLAMP SNR	Supervisory signal for the Eject Roll. High= The Eject Clamp is at the lower position. Low= The Eject Clamp is at the higher position.
SET CLAMP HOME SNR	Supervisory signal for the Set Clamp position. High= The Set Clamp is at the Home position. Low= The Set Clamp is not at the Home position.
COMPILER PAPER SNR	Supervisory signal for the paper on the Compiler Tray. High= There are paper on the Compiler Tray. Low= No paper on the Compiler Tray.
STACKER OFFSET HOME SNR	Supervisory signal for the Eject Roll position. High= The Eject Roll is at the Home position. Low= The Eject Roll is not at the Home position.
STACKER TRAY ID SNR	Supervisory signal for Stacker Tray Unit position. High= The Stacker Tray Unit is at the Home position. Low= The Stacker Tray Unit is not at the Home position.
FINISHER INTLOCK SNR	Supervisory signal for the HCS position against the Base Engine. High= The HCS is not on the right position. Low= The HCS is on the right position.

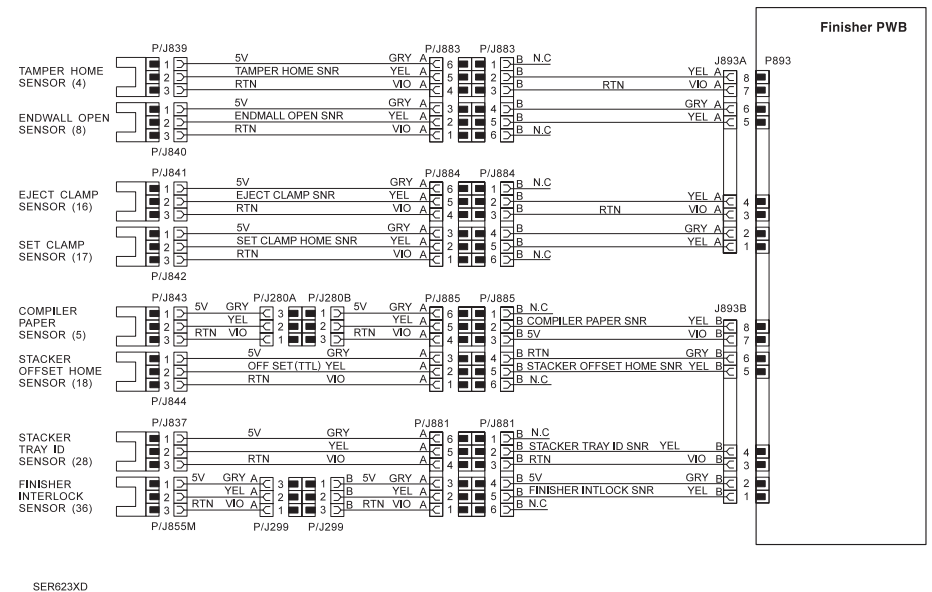

Figure 4-6. Wiring Diagram 5

**VARIOUS INTERLOCK ↔ FINISHER PWB**

The following tables show the signal names in the wiring diagram below.

Signal	Explanation
OPT\$STX+	HCS Status that sent to MCU. High=Mark Low=No mark
OPT\$RX+	MCU Status that sent to HCS. High=Mark Low=No mark
MBS#DET	Supervisory signal to check if Mail Box is installed. High=Mail Box is installed. Low=Mail Box is not installed.
FNSR#DET	Supervisory signal to check if Finisher Stapler is installed. High=Finisher Stapler is installed. Low=Finisher Stapler is not installed.
FRONT COVER INTLOCK	Supervisory signal for HCS Front Cover. High=Cover is open. Low=Cover is closed.
TOP COVER INTLOCK	Supervisory signal for HCS Top Cover. High=Cover is open. Low=Cover is closed.
COMPILER COVER INTLOCK	Supervisory signal for HCS Compiler Cover. High=Cover is open. Low=Cover is closed.

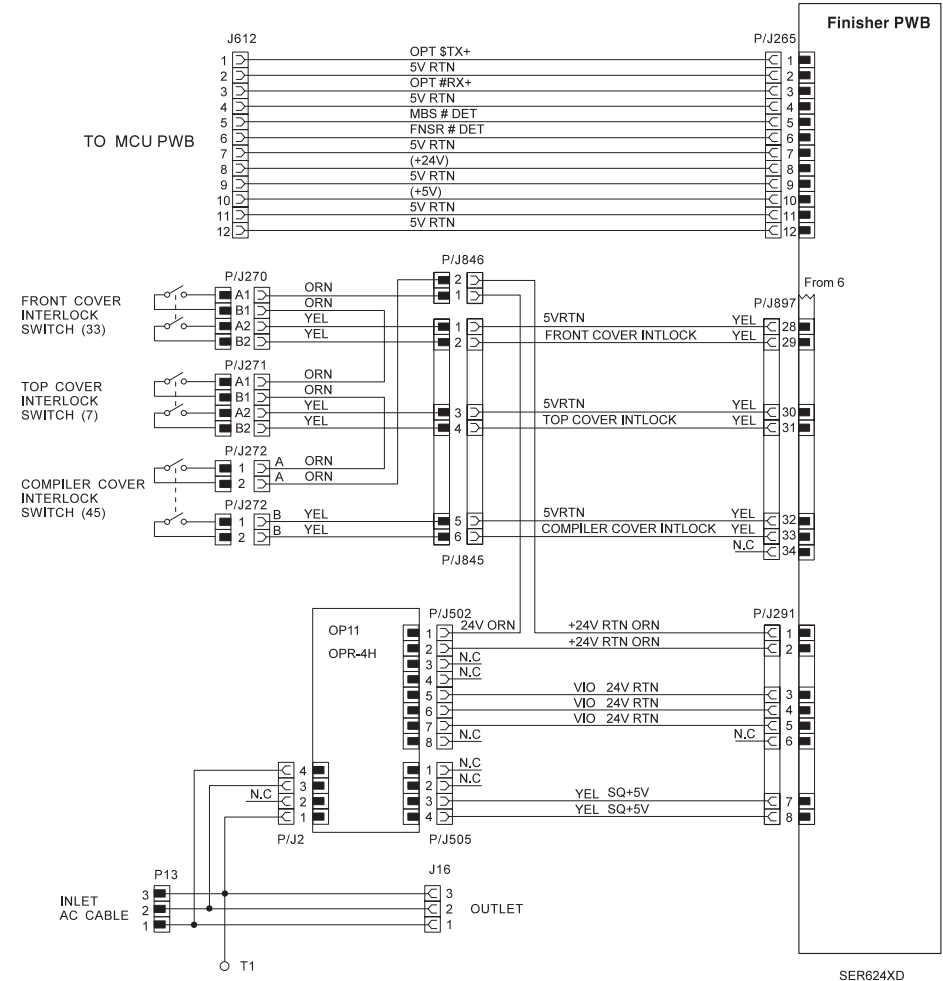

Figure 4-7. Wiring Diagram 6

**STAPLER, COMPILER TRAY SOLENOID, VARIOUS MOTORS ↔ FINISHER PWB**

The following tables show the signal names in the wiring diagram below.

Signal	Explanation
STPL MOT CW	Control signal for revolving Stapler Motor clockwise. High=ON, Low=OFF
STPL MOT CCW	Control signal for revolving Stapler Motor counterclockwise. High=ON, Low=OFF
LOW\$STPL	Supervisory signal for Staple level in the Stapler Cartridge. High=The amount of staple is low. Low=The amount of staple is enough.
CTRDRG#SET	Supervisory signal to check if Stapler Cartridge is set in the Stapler Assembly. High=Cartridge is set in. Low=Cartridge is not set in.
SH#HOME	Supervisory signal for the Stapler Head position. High=Stapler Head is at the Home position. Low=Stapler Head is not at the Home position.
STPL#RDY	Supervisory signal for Stapler Head. High=Not ready, Low=Ready
STAPLE MOVE MOTOR#A	Drive signal for Staple Move Motor. High=OFF, Low=ON
STAPLE MOVE MOTOR#A-	Drive signal for Staple Move Motor. High=OFF, Low=ON
STAPLE MOVE MOTOR#B	Drive signal for Staple Move Motor. High=OFF, Low=ON
STAPLE MOVE MOTOR#B-	Drive signal for Staple Move Motor. High=OFF, Low=ON
TAMPER MOTOR#A	Drive signal for Tamper Motor. High=OFF, Low=ON
TAMPER MOTOR#A-	Drive signal for Tamper Motor. High=OFF, Low=ON

Signal	Explanation
TAMPER MOTOR#B	Drive signal for Tamper Motor. High=OFF, Low=ON
TAMPER MOTOR#B-	Drive signal for Tamper Motor. High=OFF, Low=ON
END WALL CLOSE CW	Control signal to close End Wall while stapling. High=ON, Low=OFF
END WALL CLOSE CCW	Control signal to open End Wall while stapling. High=ON, Low=OFF
COMPILER TRAY DOWN	Control signal to shift down the Compiler Tray. High=ON, Low=OFF

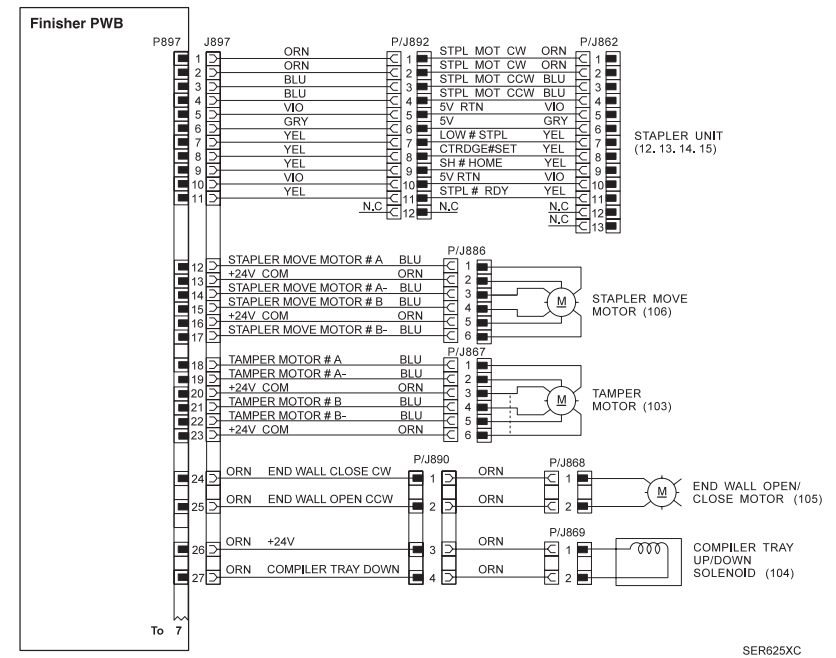

Figure 4-8. Wiring Diagram 7

**IN GATE SOLEOID, TRANSPORT MOTOR, EJECT MOTOR ↔ FINISHER PWB**

The following tables show the signal names in the wiring diagram below.

Signal	Explanation
GATE IN CLOSE PULL	Control signal to close Gate Solenoid. High=Close, Low=Not Close
GATE IN OPEN PUSH	Control signal to open Gate Solenoid. High=Open, Low=Not Open
TRANSPORT MOTOR ENABLE	Control signal to enable Transport Motor. High=Disable, Low=Enable

Signal	Explanation
TRANSPORT MOTOR ACTIVE	Control signal to activate Transport Motor. High=Inactive, Low=Active
EJECT MOTOR #A	Drive signal to revolve Stapler Motor counterwise. High=ON, Low=OFF
EJECT MOTOR #A-	Drive signal to revolve Stapler Motor counterwise. High=ON, Low=OFF
EJECT MOTOR #B	Drive signal to revolve Stapler Motor counterwise. High=ON, Low=OFF
EJECT MOTOR #B-	Drive signal to revolve Stapler Motor counterwise. High=ON, Low=OFF

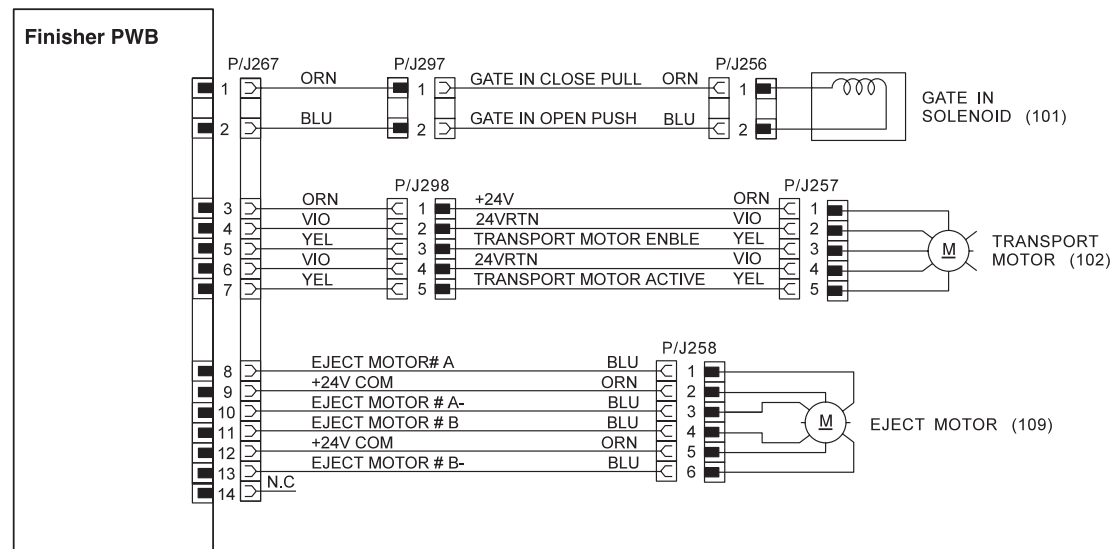

SER626XC

Figure 4-9. Wiring Diagram 8



**VARIOUS MOTORS ↔ FINISHER PWB**

The following tables show the signal names in the wiring diagram below.

Signal	Explanation
STACKER MID DOWN CCW	Control signal to shift down the Stacker Mid.
STACKER MID UP CW	Control signal to shift up the Stacker Mid.
STACKER LOW DOWN CCW	Control signal to shift down the Stacker Low.
STACKER LOW UP CW	Control signal to shift up the Stacker Low.
EJECT CLAMP & OFFSET MOT CW	Control signal to shift down the Eject Clamp Offset.
EJECT CLAMP & OFFSET MOT CCW	Control signal to shift up the Eject Clamp Offset.
SET CLAMP MOT-	Control signal to shift the Set Clamp Offset Motor.
SET CLAMP MOT+	Control signal to shift the Set Clamp Offset Motor.
STACKER TOP SAFETY IN	Supervisory signal for the obstruction at the lower side of the Top Tray and Middle Tray.
STACKER TOP SAFETY OUT	Supervisory signal for the obstruction at the lower side of the Top Tray and Middle Tray.
STACKER TOP UP CW	Control signal to shift up the Stacker Top.
STACKER TOP DOWN CCW	Control signal to shift sown the Stacker Top.
STACKER UPPER LIMIT SW	Supervisory signal for Stacker abnormal rise. High=Stacker has reached the upper limit position. Low=Stacker is under the upper limit position.
STACKER LOWER LIMIT SW	Supervisory signal for Stacker abnormal fall. High=Stacker has reached the lower limit position. Low=Stacker is above the lower limit position.
STACKER UNIT UP CCW	Control signal to shift up the Stacker Tray Unit.
STACKER UNIT DOWN CW	Control signal to shift down the Stacker Tray Unit.

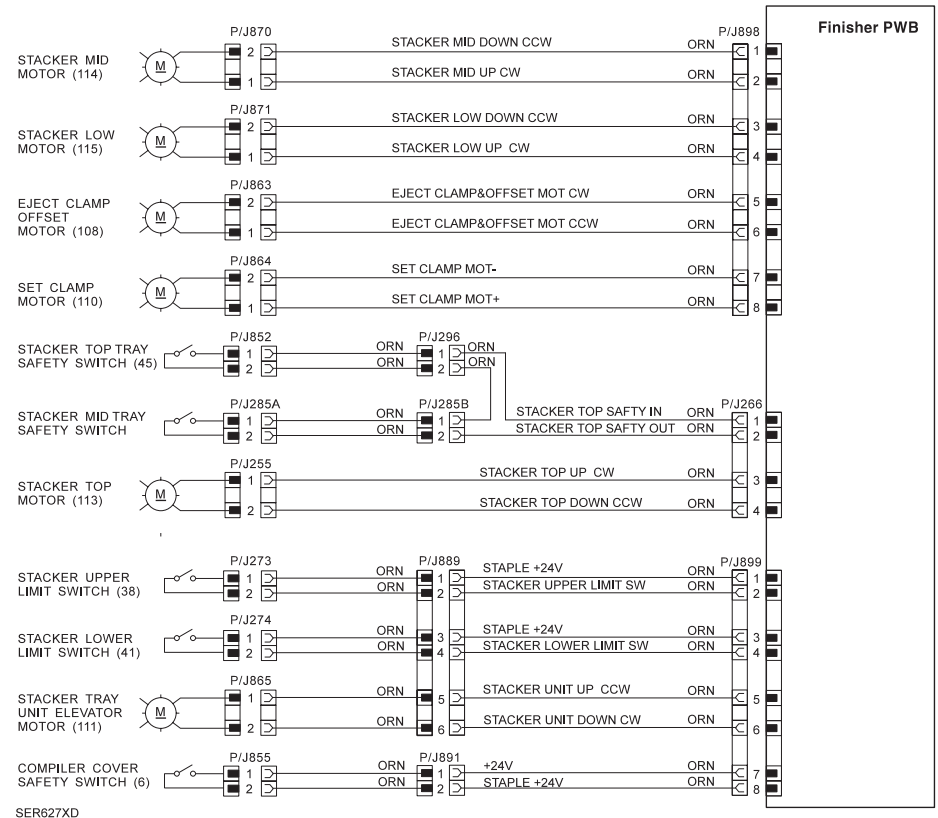

Figure 4-10. Wiring Diagram 9

## 4.2 Connector

### 4.2.1 P/J Connector Table and Location Map

The tables and figures allows you to easily find the location of the connector P/J of the finisher stapler.

1. Find P/J connector number you are looking for on the first column of the table.
2. The second column tells you which figure (P/J Connector Location Map) you should look at.
3. Find the connector on the map.

P/J	Figure	Component at the end of the Connector	Component at the end of the Harness
2	Figure 4-20	LVPS-OP11 PWB	P/J13 AC Power Inlet
250	Figure 4-12	Stacker Top Paper Sensor	P/J264 Finisher PWB
251	Figure 4-12	Stacker Top Half Sensor	P/J264 Finisher PWB
252	Figure 4-12	Stacker Top Full Sensor	P/J264 Finisher PWB
253	Figure 4-12	Stacker Top Upper Limit Sensor	P/J264 Finisher PWB
254	Figure 4-12	Stacker Top Lower Limit Sensor	P/J264 Finisher PWB
255	Figure 4-12 Figure 4-21	Tray1 Stacker Motor	P/J266 Finisher PWB
256	Figure 4-19	IN Gate Solenoid	P/J267 Finisher PWB
257	Figure 4-18	Transport Motor	P/J267 Finisher PWB
258	Figure 4-18 Figure 4-21	Eject Motor	P/J267 Finisher PWB
259	Figure 4-19	IOT Full Sensor	P/J896 Finisher PWB
260	Figure 4-19	Gate IN Interlock Sensor	P/J896 Finisher PWB
261	Figure 4-19	Transport Interlock Sensor	P/J896 Finisher PWB
262	Figure 4-19	P/J257M Transport Entrance Sensor	P/J854 Finisher PWB
263	Figure 4-19	Transport Exit Sensor	P/J854 Finisher PWB

P/J	Figure	Component at the end of the Connector	Component at the end of the Harness
264	Figure 4-20 Figure 4-21	Finisher PWB	P/J250 Stacker Top Paper Sensor P/J251 Stacker Top Half Sensor P/J252 Stacker Top Full Sensor P/J253 Stacker Top Upper Limit Sensor P/J254 Stacker Top Lower Limit Sensor
265	Figure 4-20 Figure 4-23	Finisher PWB	P/J816 MCU PWB
266	Figure 4-20 Figure 4-21	Finisher PWB	P/J852 Stacker Tray Safety Switch P/J255 Tray1 1 Stacker Motor
267	Figure 4-20 Figure 4-21	Finisher PWB	P/J256 IN Gate Solenoid P/J257 Transport Motor P/J258 Eject Motor
268	Figure 4-19	P/J259 IOT Full Paper Sensor	P/J896 Finisher PWB
270	Figure 4-17	Front Cover Interlock Switch	P/J897 Finisher PWB
271	Figure 4-17	Top Cover Interlock Switch	P/J897 Finisher PWB
272 A/B	Figure 4-17	Compiler Cover Interlock Switch	P/J897 Finisher PWB
273	Figure 4-11	Stacker Upper Limit Switch	P/J899 Finisher PWB
274	Figure 4-11	Stacker Lower Limit Switch	P/J899 Finisher PWB
275 M	Figure 4-19	Transport Entrance Sensor	P/J854 Finisher PWB
279	Figure 4-19	P/J261 Transport Interlock Sensor	P/J896 Finisher PWB
280	Figure 4-16	P/J843 Compiler Paper Sensor	P/J893 Finisher PWB

P/J	Figure	Component at the end of the Connector	Component at the end of the Harness
285B	Figure 4-21	P/J285A Middle Tray Safety Switch	P/J266 Finisher PWB
291	Figure 4-20	Finisher PWB	P/J502 LVPS-OP11 PWB P/J505 LVPS-OP11 PWB
292	Figure 4-21	P/J264 Finisher PWB	P/J250 Stacker Top Paper Sensor
293	Figure 4-12	P/J250 Stacker Top Paper Sensor	P/J264 Finisher PWB
294	Figure 4-21	P/J264 Finisher PWB	P/J251 Stacker Top Half Sensor P/J252 Stacker Top Full Sensor
295	Figure 4-21	P/J264 Finisher PWB	P/J253 Stacker Top Upper Limit Sensor P/J252 Stacker Top Lower Limit Sensor
296	Figure 4-21	P/J266 Finisher PWB	P/J852 Stacker Tray Safety Switch
297	Figure 4-21	P/J266 Finisher PWB	P/J256 IN Gate Solenoid
298	Figure 4-21	P/J266 Finisher PWB	P/J257 Transport Motor
299	Figure 4-11	P/J855 Finisher Interlock Sensor	P/J893 Finisher PWB
502	Figure 4-20	LVPS-OP11	P/J291 Finisher PWB P/J846 Interlock
505	Figure 4-20	LVPS-OP11	P/J291 Finisher PWB
612	Figure 4-23	P/J265 Finisher PWB	Output Jack of the Base Engine & P/J405 MCU PWB
830	Figure 4-21	P/J894B Finisher PWB	P/J850 Stacker Low Upper Limit Sensor
831	Figure 4-14	Stacker Lower Safety Sensor	P/J894B Finisher PWB
832	Figure 4-16	Stacker High Sensor	P/J896 Finisher PWB
833	Figure 4-15	Stapler Front Corner Sensor	P/J896 Finisher PWB

P/J	Figure	Component at the end of the Connector	Component at the end of the Harness
834	Figure 4-15	Stapler Front Straight Sensor	P/J895B Finisher PWB
835	Figure 4-15	Stapler Front Straight Sensor	P/J895B Finisher PWB
836	Figure 4-17	Unload While Run Switch & Unload While Run LED	P/J895B Finisher PWB
837	Figure 4-11	Stacker Tray ID Sensor	P/J893B Finisher PWB
838	Figure 4-16	Compiler Tray Exit Sensor	P/J896 Finisher PWB
839	Figure 4-16	Tamper Home Sensor	P/J893 Finisher PWB
840	Figure 4-16	End Wall Open Sensor	P/J893 Finisher PWB
841	Figure 4-18	Eject Clamp Sensor	P/J893 Finisher PWB
842	Figure 4-18	Set Clamp Sensor	P/J893 Finisher PWB
843	Figure 4-16	Compiler Paper Sensor	P/J893 Finisher PWB
844	Figure 4-18	Stacker Offset Home Sensor	P/J893 Finisher PWB
845	Figure 4-23	P/J897 Finisher PWB	P/J270 Front Cover Interlock Switch P/J271 Top Cover Interlock Switch P/J272 Compiler Cover Interlock Switch P/J833 Stapler Front Corner Sensor
847	Figure 4-23	P/J895B Finisher PWB	P/J833 Stapler Front Corner Sensor
848	Figure 4-13	Stacker Mid Upper Limit Sensor	P/J894 Finisher PWB
849	Figure 4-13	Stacker Mid Lower Limit Sensor	P/J894 Finisher PWB
850	Figure 4-14	Stacker Low Upper Limit Sensor	P/J894B Finisher PWB
851	Figure 4-14	Stacker Low Lower Limit Sensor	P/J894B Finisher PWB
852	Figure 4-12	Stacker Tray Safety Switch	P/J266 Finisher PWB

P/J	Figure	Component at the end of the Connector	Component at the end of the Harness
854	Figure 4-20 Figure 4-23	Finisher PWB	P/J263 Transport Exit Sensor P/J275M Transport Entrance Sensor
855	Figure 4-17	Compiler Cover Safety Switch	P/J899 Finisher PWB
855 M	Figure 4-11	Finisher Interlock Switch	P/J893B Finisher PWB
856	Figure 4-13	Stacker Mid Paper Sensor	P/J894 Finisher PWB
857	Figure 4-13	Stacker Mid Half Sensor	P/J894 Finisher PWB
858	Figure 4-13	Stacker Mid Full Sensor	P/J894 Finisher PWB
859	Figure 4-14	Stacker Low Paper Sensor	P/J894B Finisher PWB
860	Figure 4-14	Stacker Low Half Sensor	P/J894B Finisher PWB
861	Figure 4-14	Stacker Low Full Sensor	P/J894B Finisher PWB
862	Figure 4-15	Stapler	Finisher PWB
863	Figure 4-18 Figure 4-21	Eject Clamp Offset Motor	P/J898 Finisher PWB
864	Figure 4-18 Figure 4-21	Set Clamp Motor	P/J898 Finisher PWB
865	Figure 4-11	Stacker Tray Elevator Motor	P/J899 Finisher PWB
866	Figure 4-23	P/J896 Finisher PWB	P/J838 Compiler Tray Exit Sensor
867	Figure 4-16 Figure 4-23	Tamper Motor	P/J897 Finisher PWB
868	Figure 4-17	End Wall Open/Close Motor	P/J897 Finisher PWB
869	Figure 4-16 Figure 4-23	Compiler Tray Up/Down Solenoid	P/J897 Finisher PWB
870	Figure 4-13 Figure 4-19	Stacker Mid Motor	P/J898 Finisher PWB
871	Figure 4-14 Figure 4-21	Stacker Lower Motor	P/J898 Finisher PWB
872	Figure 4-21	P/J894 Finisher PWB	P/J856 Stacker Mid Paper Sensor

P/J	Figure	Component at the end of the Connector	Component at the end of the Harness
873	Figure 4-21	P/J894B Finisher PWB	P/J857 Stacker Mid Half Sensor P/J858 Stacker Mid Full Sensor
874	Figure 4-21	P/J894B Finisher PWB	P/J831 Stacker Lower Safety Sensor P/J859 Stacker Lower Paper Sensor
875	Figure 4-21	P/J894B Finisher PWB	P/J860 Stacker Lower Half Sensor P/J861 Stacker Lower Full Sensor
877	Figure 4-23	P/J895B Finisher PWB	P/J834 Stapler Front Straight Sensor P/J835 Stapler Rear Stapler Straight Sensor
878	Figure 4-23 Figure 4-16	P/J895B Finisher PWB	P/J836 Unload While Run Switch & Unload While Run LED
880	Figure 4-23	P/J896 Finisher PWB	P/J259 IOT Full Paper Sensor P/J260 Gate IN Interlock Sensor
881	Figure 4-22 Figure 4-11	P/J893 Finisher PWB	P/J855M Finisher Interlock Sensor P/J837 Stacker Tray ID Sensor
882	Figure 4-23	P/J896 Finisher PWB	P/J261 Transport Interlock Sensor
883	Figure 4-22 Figure 4-16	P/J893 Finisher PWB	P/J893 Tamper Home Sensor P/J840 End Wall Open Sensor
884	Figure 4-22	P/J893 Finisher PWB	P/J841 Eject Clamp Sensor P/J842 Set Clamp Sensor

P/J	Figure	Component at the end of the Connector	Component at the end of the Harness
885	Figure 4-22	P/J893B Finisher PWB	P/J843 Compiler Paper Sensor P/J842 Stacker Offset Home Sensor
886	Figure 4-14 Figure 4-23	Stapler Move Motor	P/J897 Finisher PWB
887	Figure 4-21	Tamper Motor	P/J897 Finisher PWB
888	Figure 4-14	P/J859 Stacker Lower Paper Sensor P/J831 Stacker Lower Safety Sensor	P/J894 Finisher PWB
889	Figure 4-11 Figure 4-22	Compiler Up/Down Solenoid	P/J897 Finisher PWB
890	Figure 4-23	P/J897 Finisher PWB	P/J868 End Wall Open/Close Motor P/J869 Compiler Tray Up/Down Solenoid
891	Figure 4-22	P/J855 Compiler Cover Safety Switch	P/J899 Finisher PWB
892	Figure 4-15 Figure 4-23	P/J897 Finisher PWB	P/J862 Stapler
893	Figure 4-20 Figure 4-22	Finisher PWB	P/J837 Stacker Tray ID Sensor P/J839 Tamper Home Sensor P/J840 End Wall Open Sensor P/J841 Eject Clamp Sensor P/J842 Set Clamp Sensor P/J843 Compiler Paper Sensor P/J844 Stacker Offset Home Sensor P/J855 Finisher Interlock Sensor

P/J	Figure	Component at the end of the Connector	Component at the end of the Harness
894	Figure 4-20 Figure 4-21	Finisher PWB	P/J831 Stacker Lower Safety Switch P/J848 Stacker Mid Upper Limit Sensor P/J849 Stacker Mid Lower Limit Sensor P/J850 Stacker Low Upper Limit Sensor P/J851 Stacker Low Lower Limit Sensor P/J856 Stacker Mid Paper Sensor P/J857 Stacker Mid Half Sensor P/J858 Stacker Mid Full Sensor P/J859 Stacker Low Paper Sensor P/J801 Stacker Low Half Sensor P/J861 Stacker Low Full Sensor
895	Figure 4-13	P/J856 Stacker Mid Paper Sensor	P/J894 Finisher PWB
896	Figure 4-20 Figure 4-23	Finisher PWB	P/J259 IOT Full Paper Sensor P/J260 IN Gate Interlock Sensor P/J261 Transport Interlock Sensor P/J832 Stack High Sensor P/J838 Compiler Tray Exit Sensor

P/J	Figure	Component at the end of the Connector	Component at the end of the Harness
897	Figure 4-20A Figure 4-23	Finisher PWB	P/J862 Stapler P/J868 End Wall Open/Close Motor P/J869 Compiler Tray Up/Down Solenoid P/J886 Stapler Move Motor P/J887 Tamper Motor
898	Figure 4-20A Figure 4-21	Finisher PWB	P/J863 Eject Clamp Offset Motor P/J864 Set Clamp Motor P/J870 Stacker Mid Motor P/J871 Stacker Low Motor
899	Figure 4-20A Figure 4-21	Finisher PWB	P/J253 Stacker Upper Limit Switch P/J254 Stacker Lower Limit Switch P/J855 Compiler Cover Safety Switch P/J865 Stacker Tray Elevator Motor

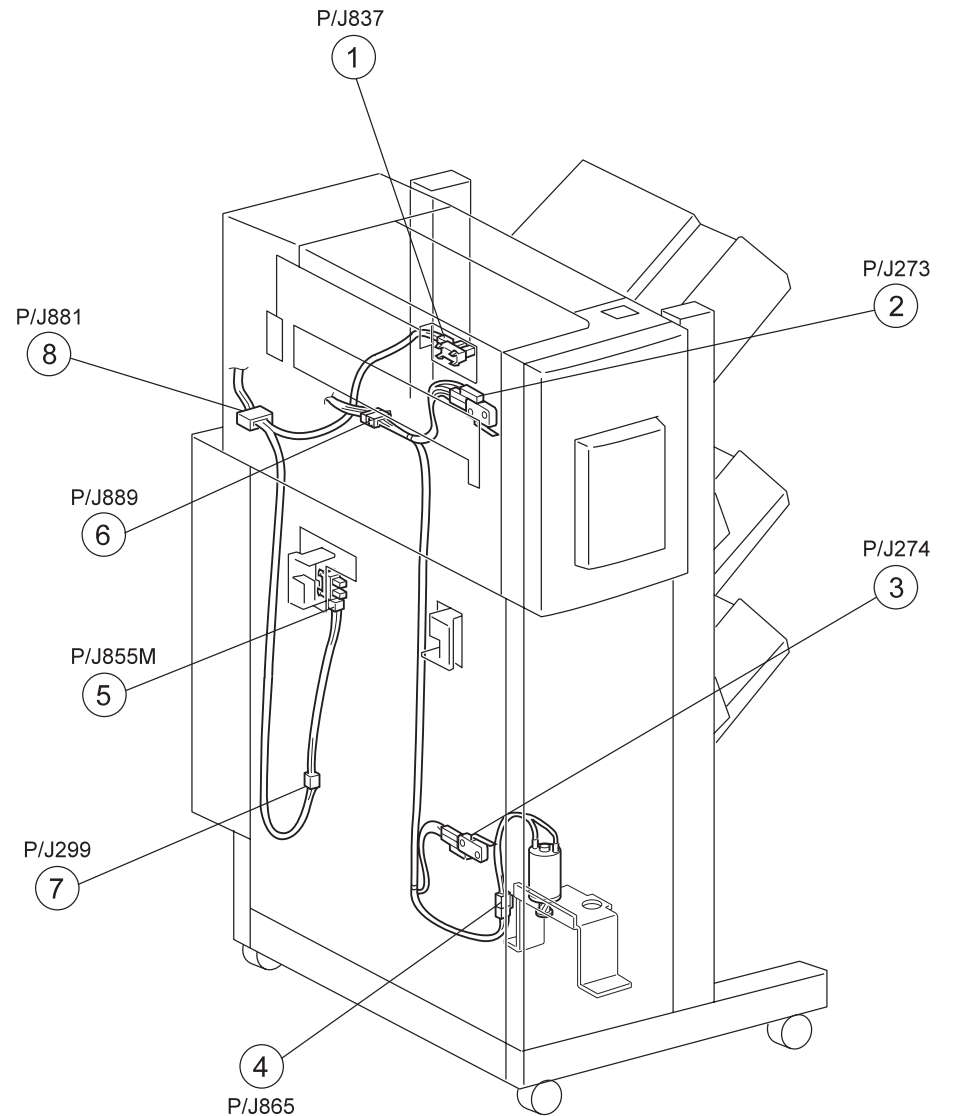

SSH700F

Figure 4-11. P/J Location Map

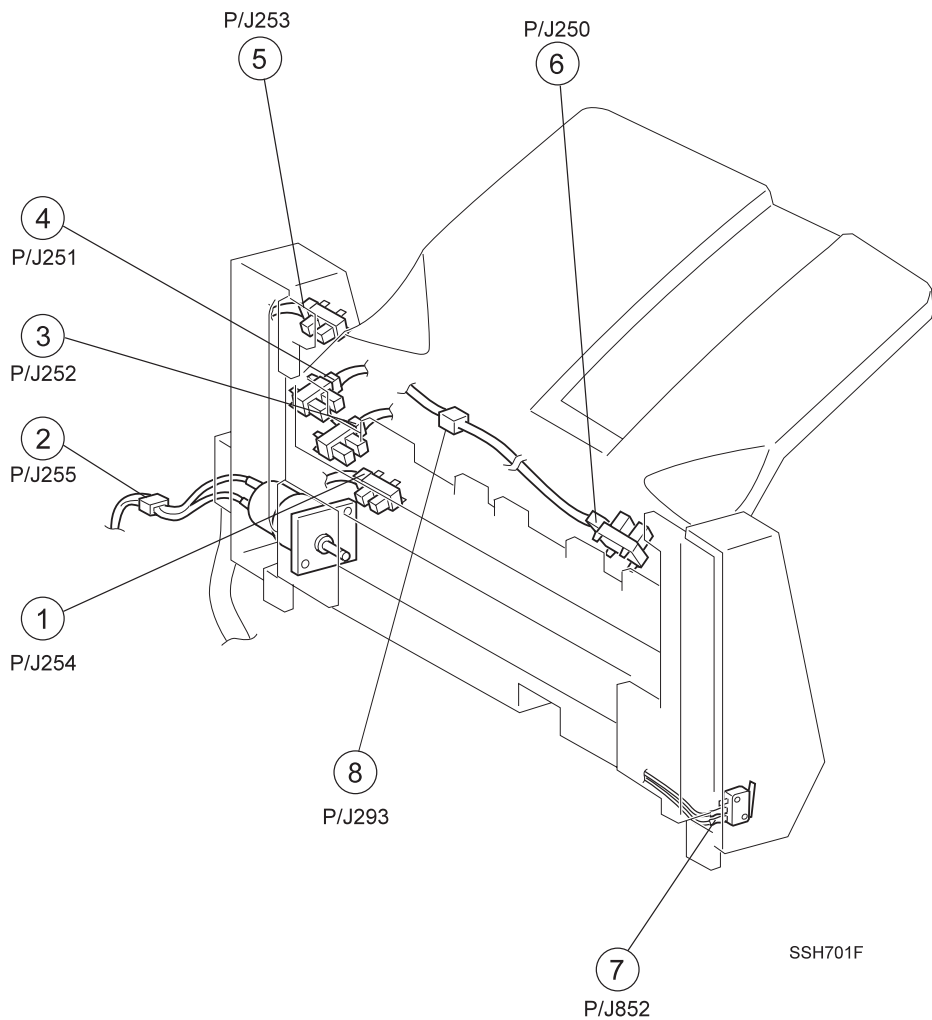

Figure 4-12. P/J Location Map

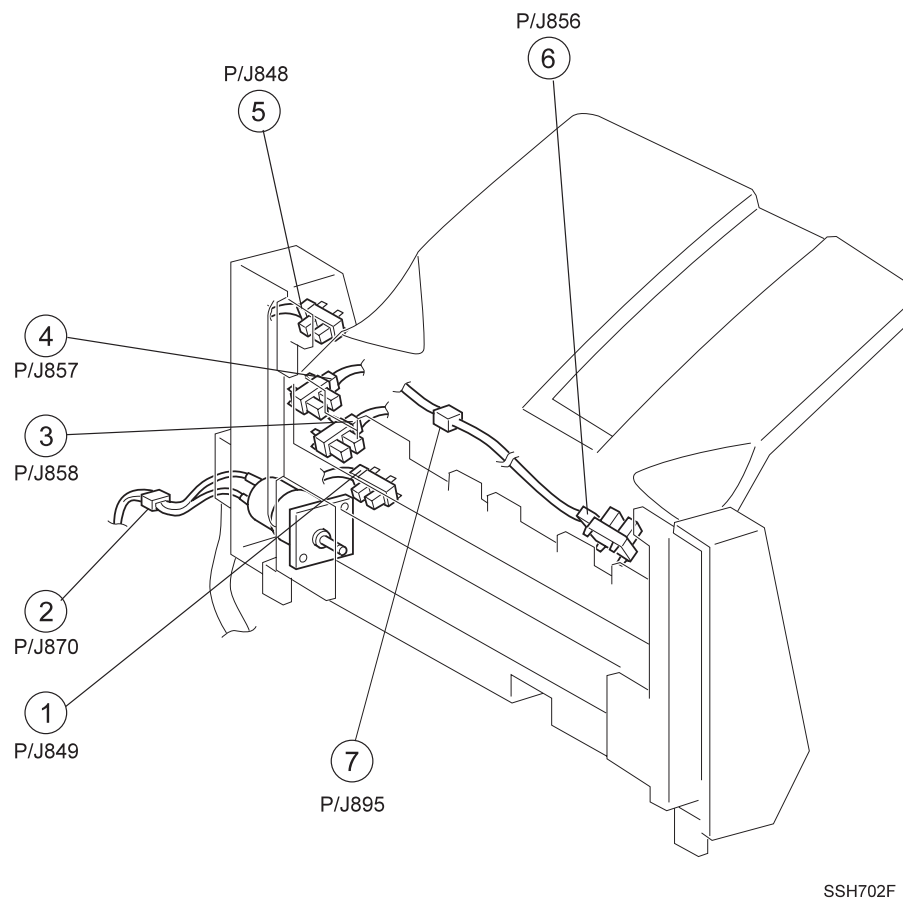

Figure 4-13. P/J Location Map

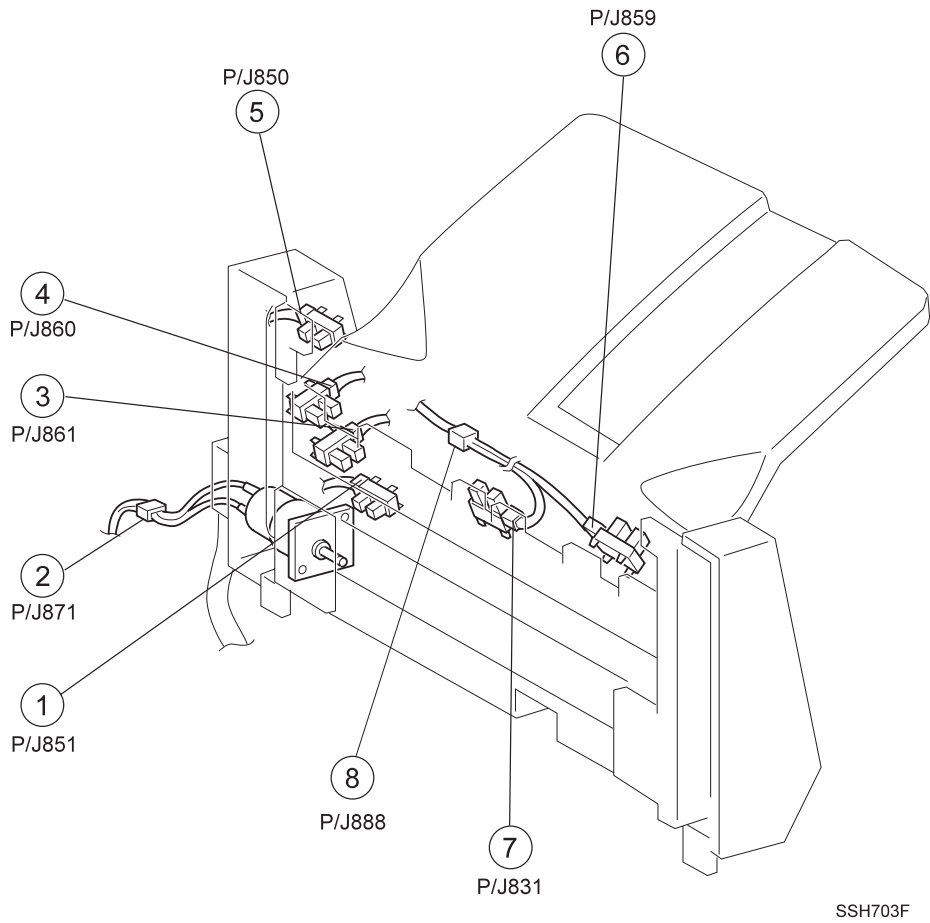

Figure 4-14. P/J Location Map

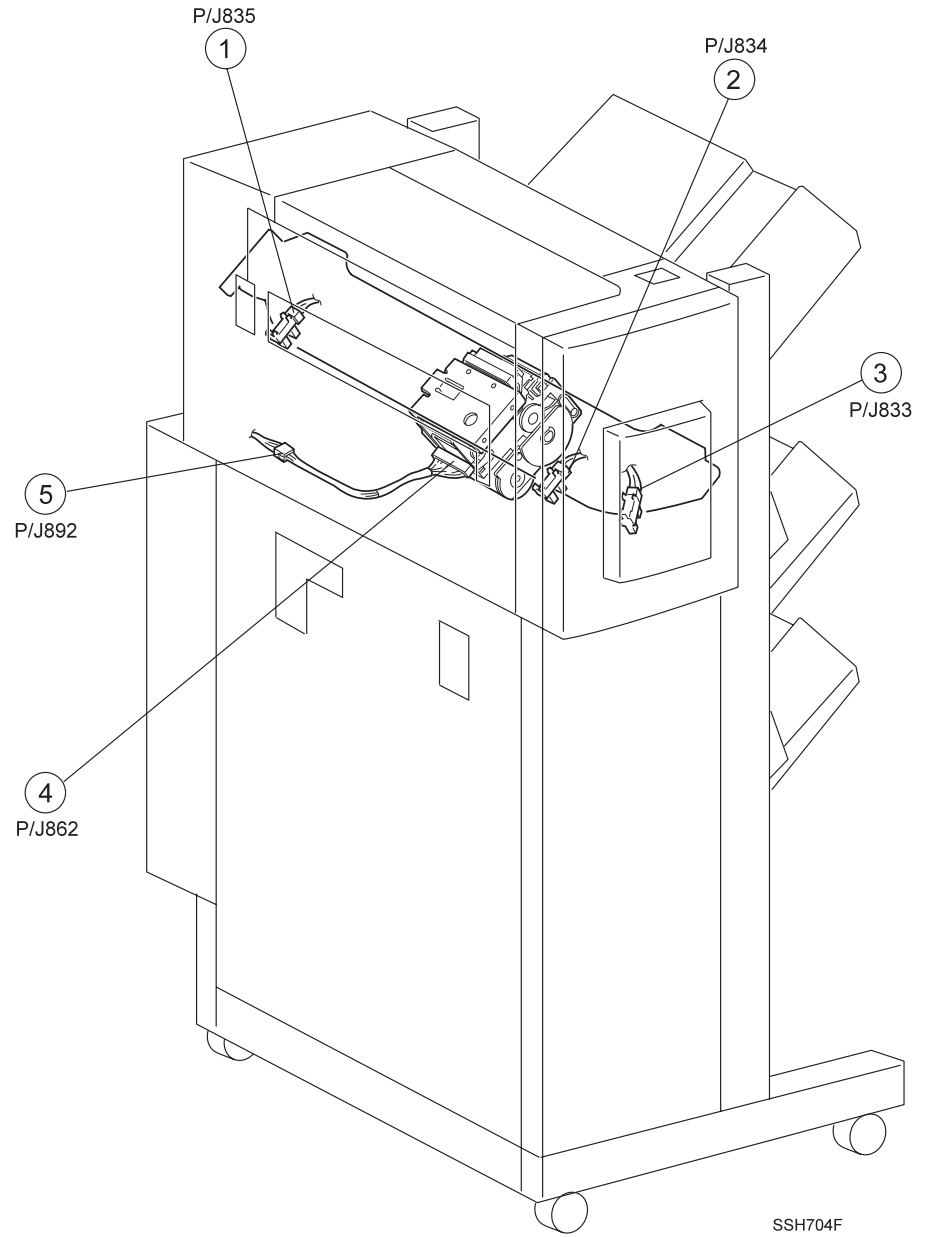
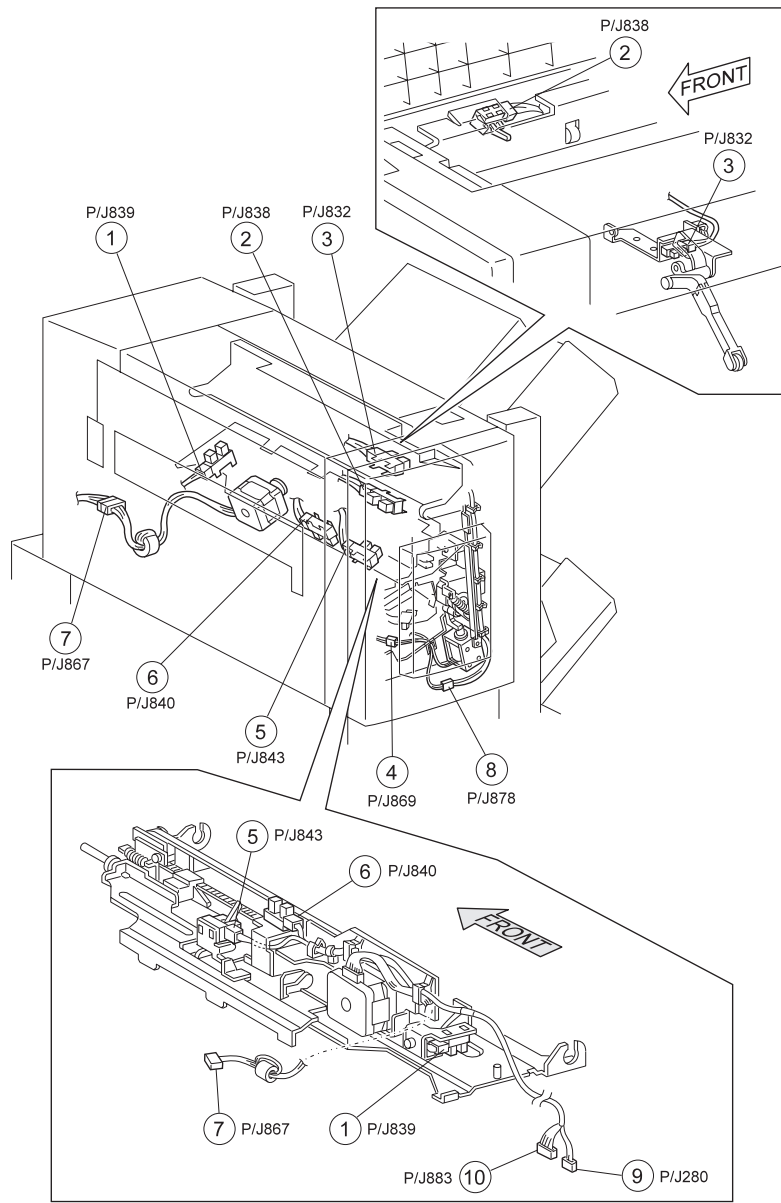

Figure 4-15. P/J Location Map





SSH705F

Figure 4-16. P/J Location Map

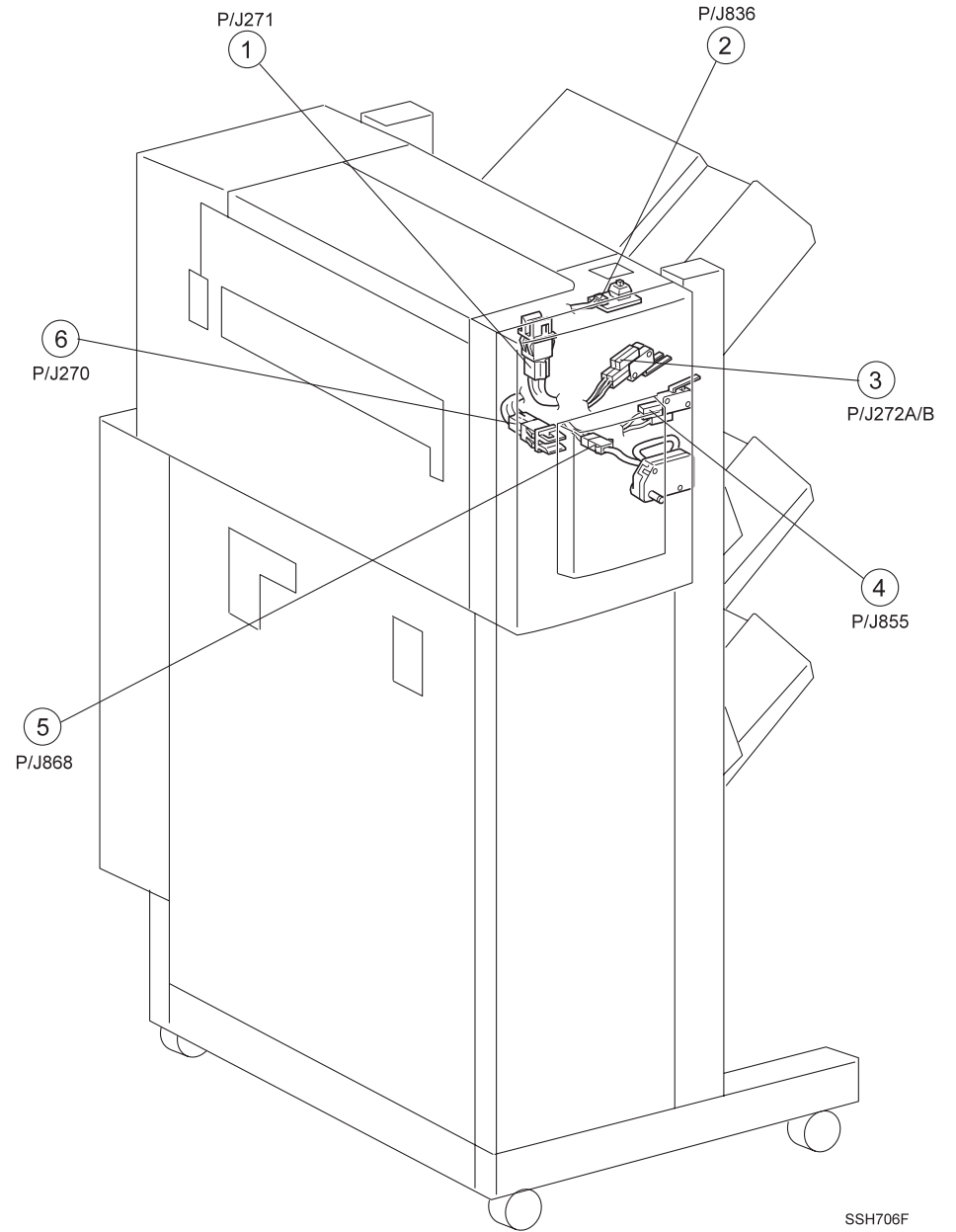

SSH706F

Figure 4-17. P/J Location Map

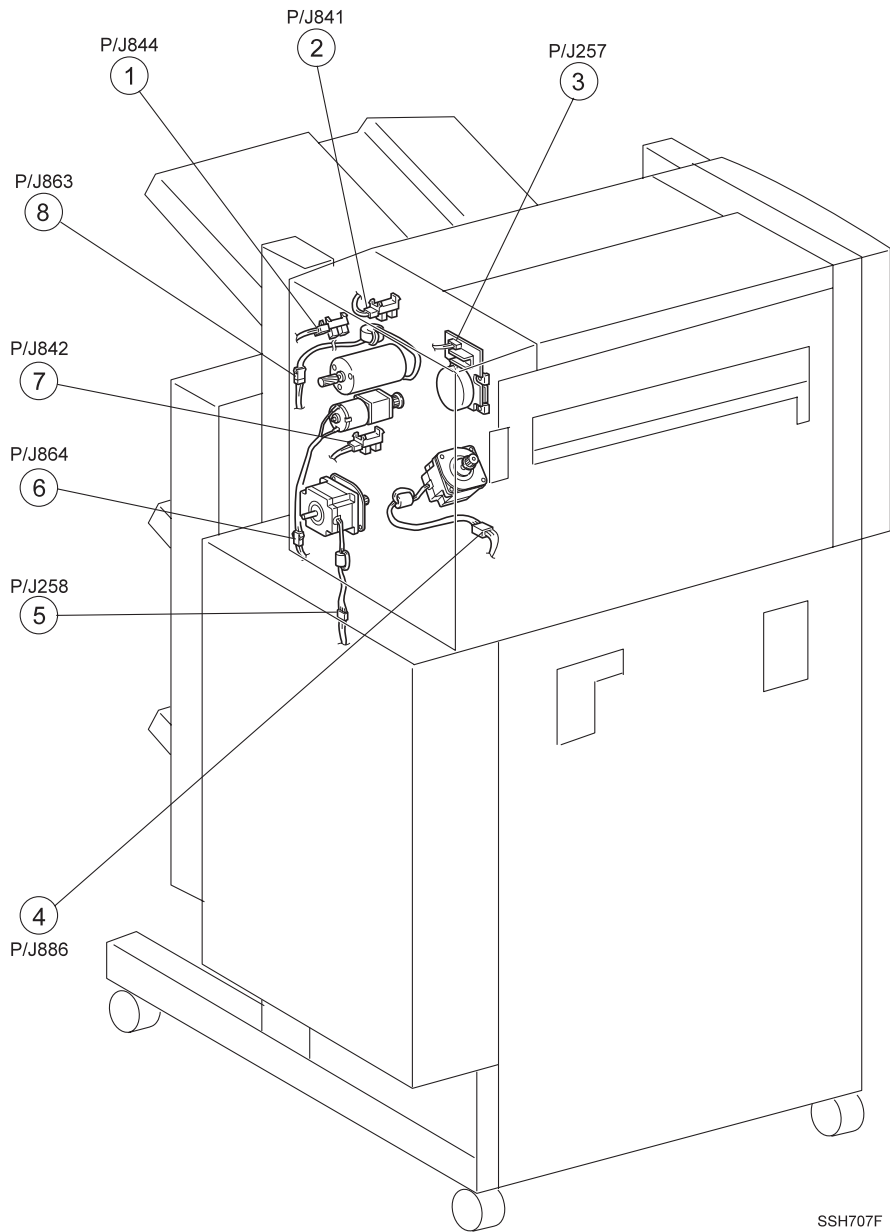

Figure 4-18. P/J Location Map

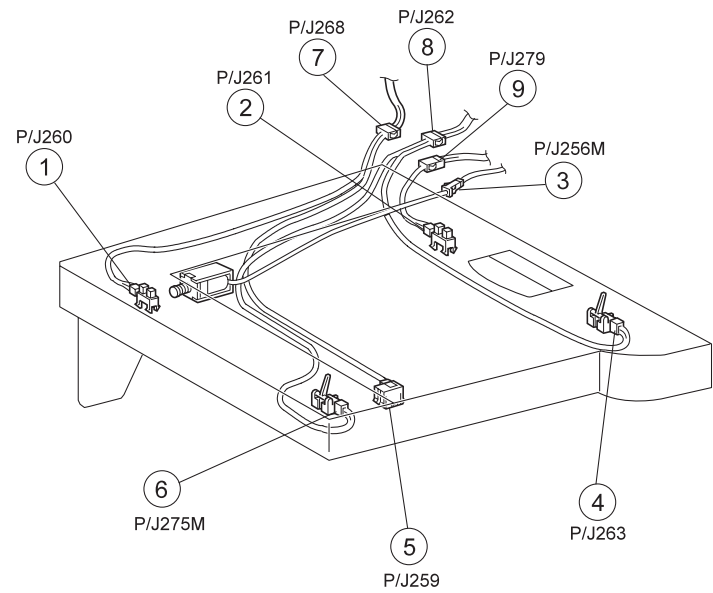
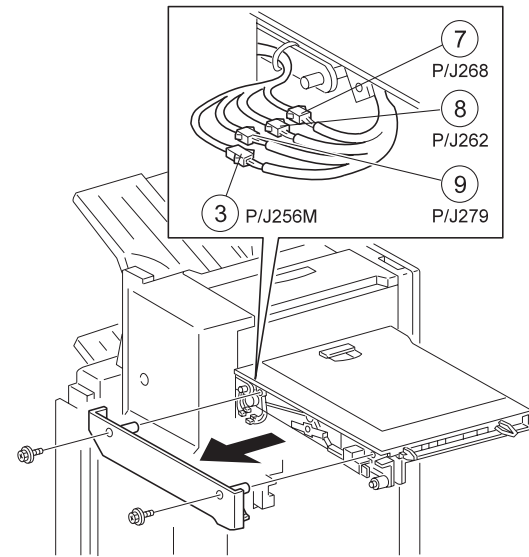

Figure 4-19. P/J Location Map

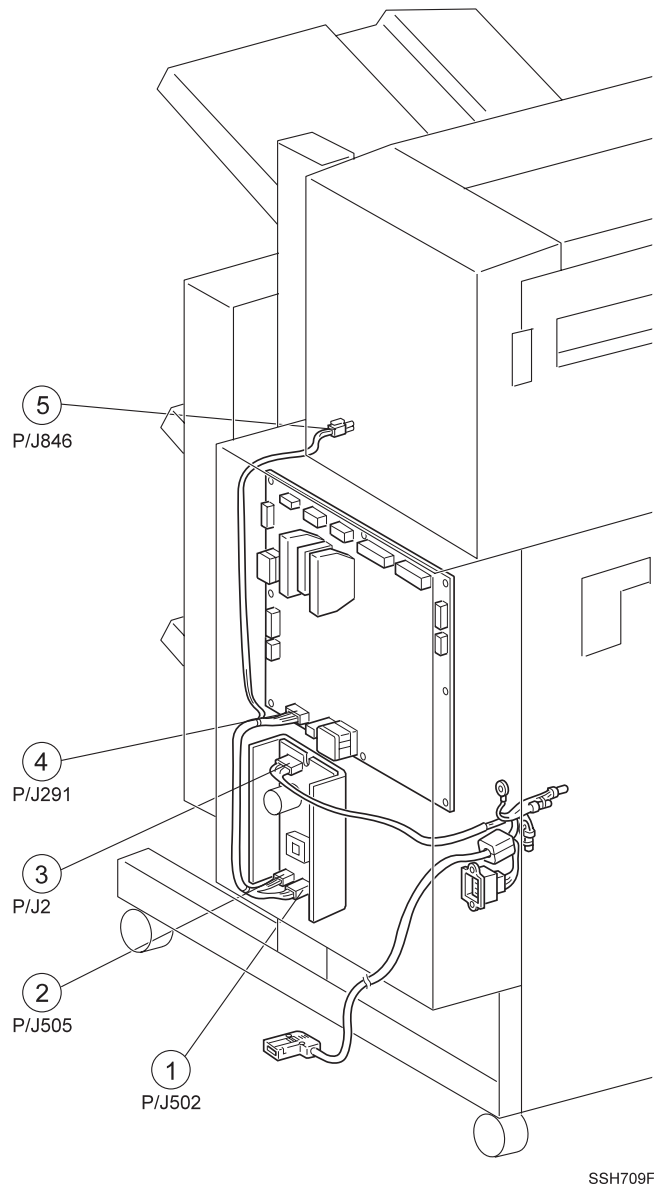

Figure 4-20. P/J Location Map

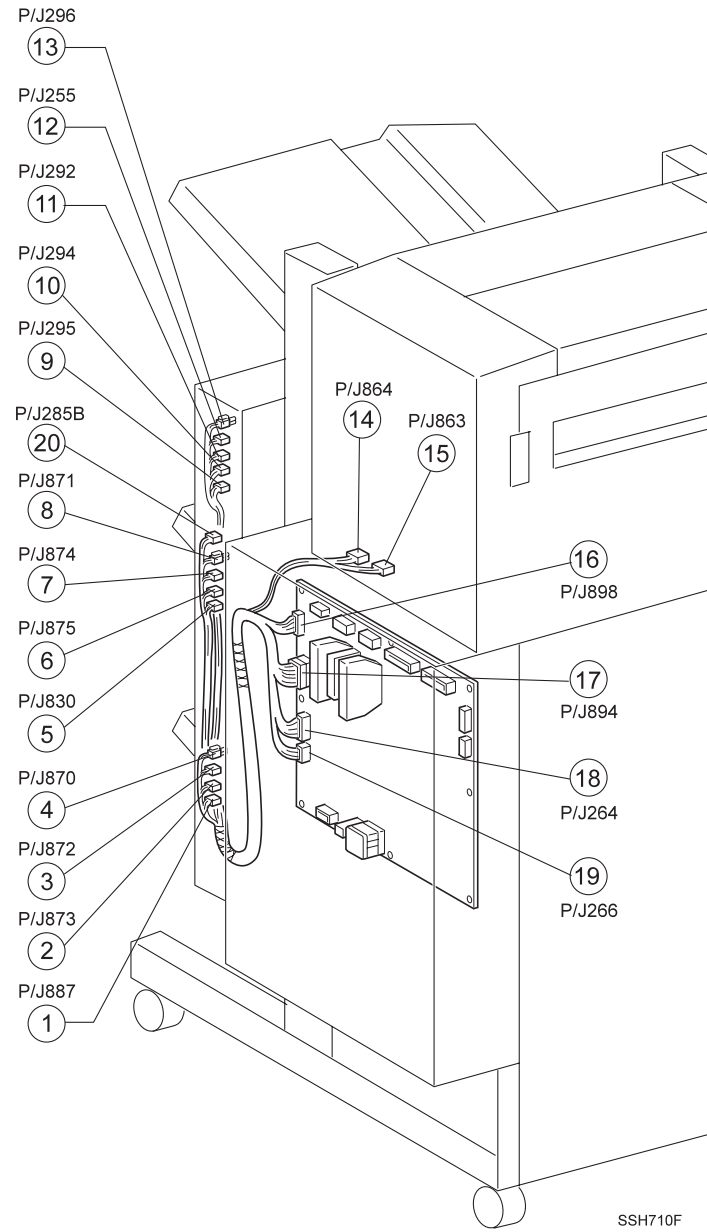

Figure 4-21. P/J Location Map

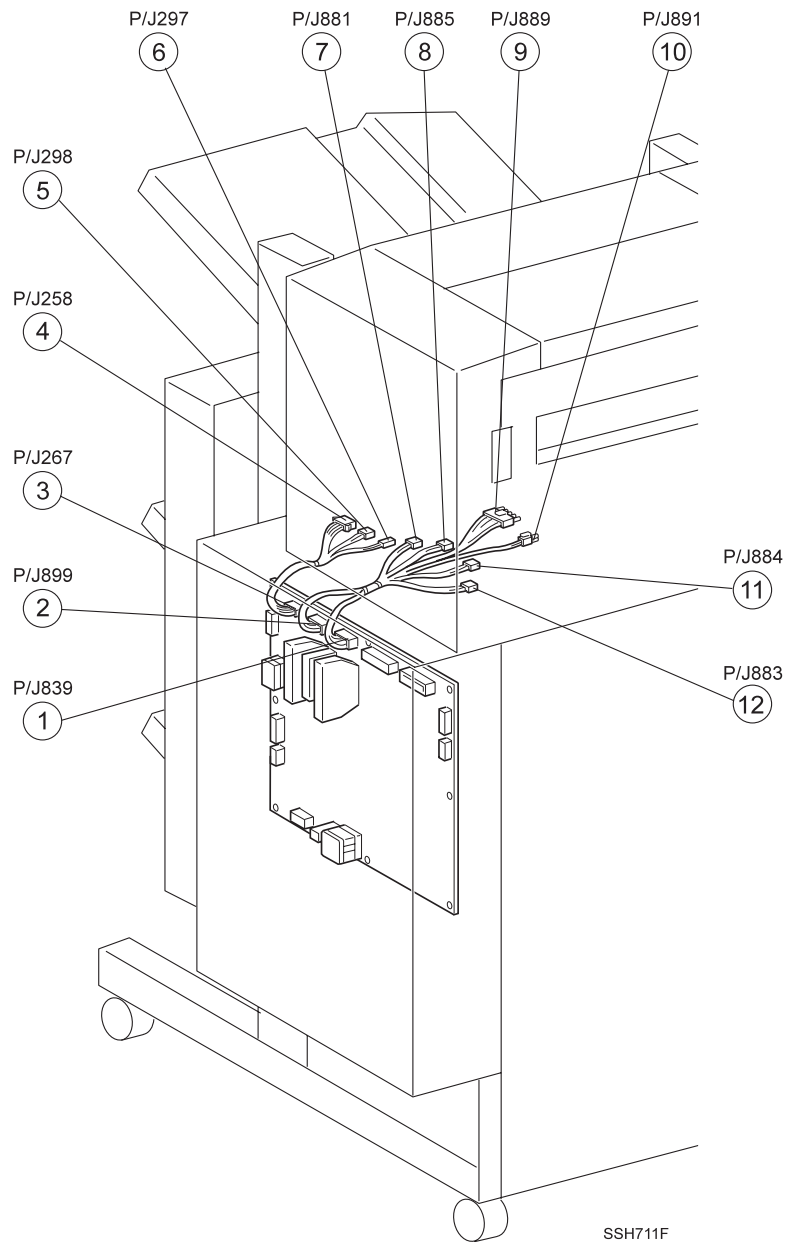

Figure 4-22. P/J Location Map

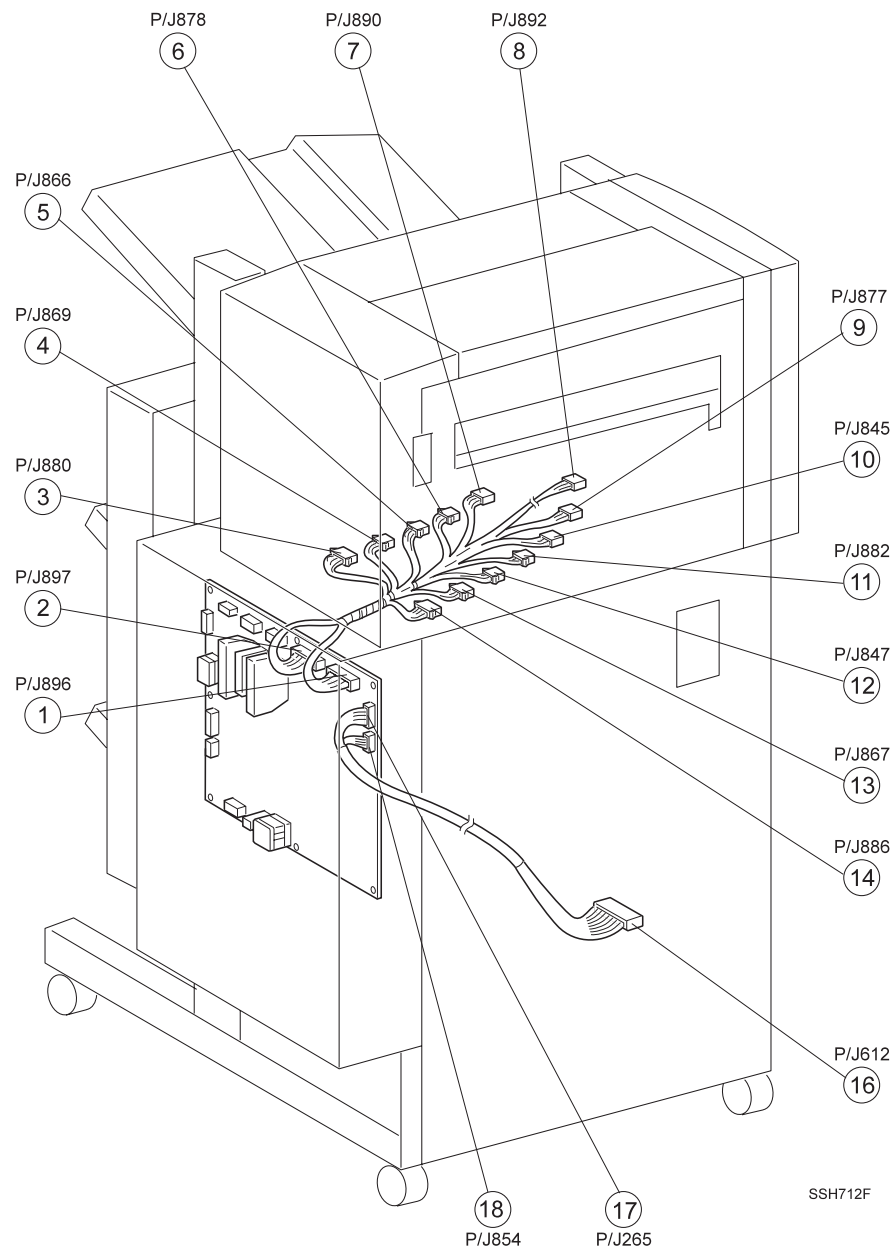
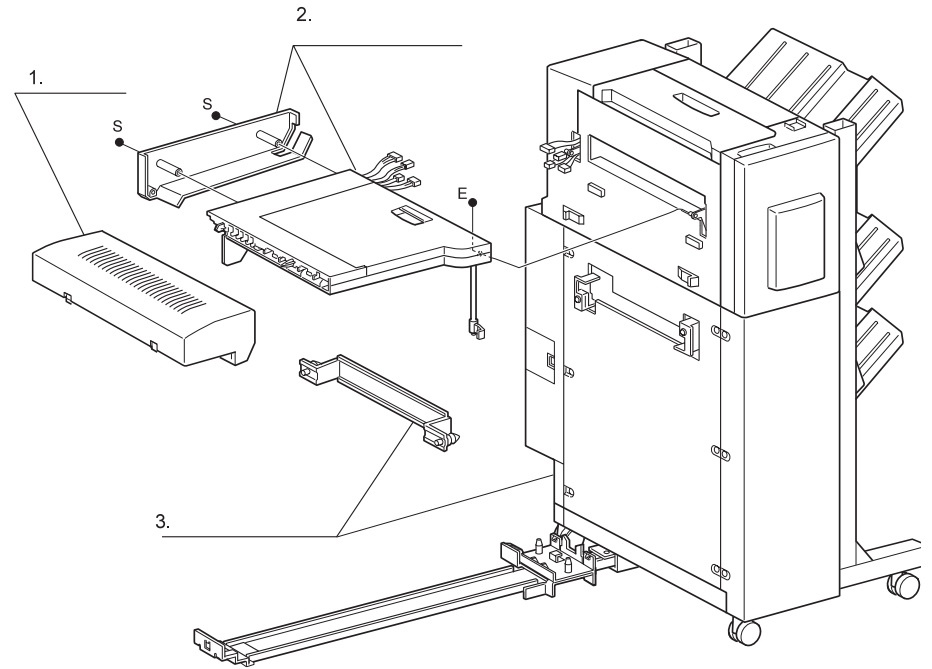

Figure 4-23. P/J Location Map

## 4.3 Exploded Diagram and Parts List

### 4.3.1 HCS Transport

- 1. REFERENCE ONLY
- 2. REFERENCE ONLY
- 3. REFERENCE ONLY



SER565F

Figure 4-24. HCS Transport

### 4.3.2 HCS Covers Front

1. COVER FRONT INNER ASSEMBLY (with 2, 3, 4)
2. --
3. --
4. --
5. COVER FRONT ASSEMBLY
6. --
7. --
8. --
9. --
10. --
11. --
12. --
13. COVER L/H
14. COVER LOW L/H
15. --
16. COVER FRONT LOW
17. BRACKET ASSEMBLY EMI
18. RAIL ASSEMBLY DOCKING
19. KNOB ASSEMBLY

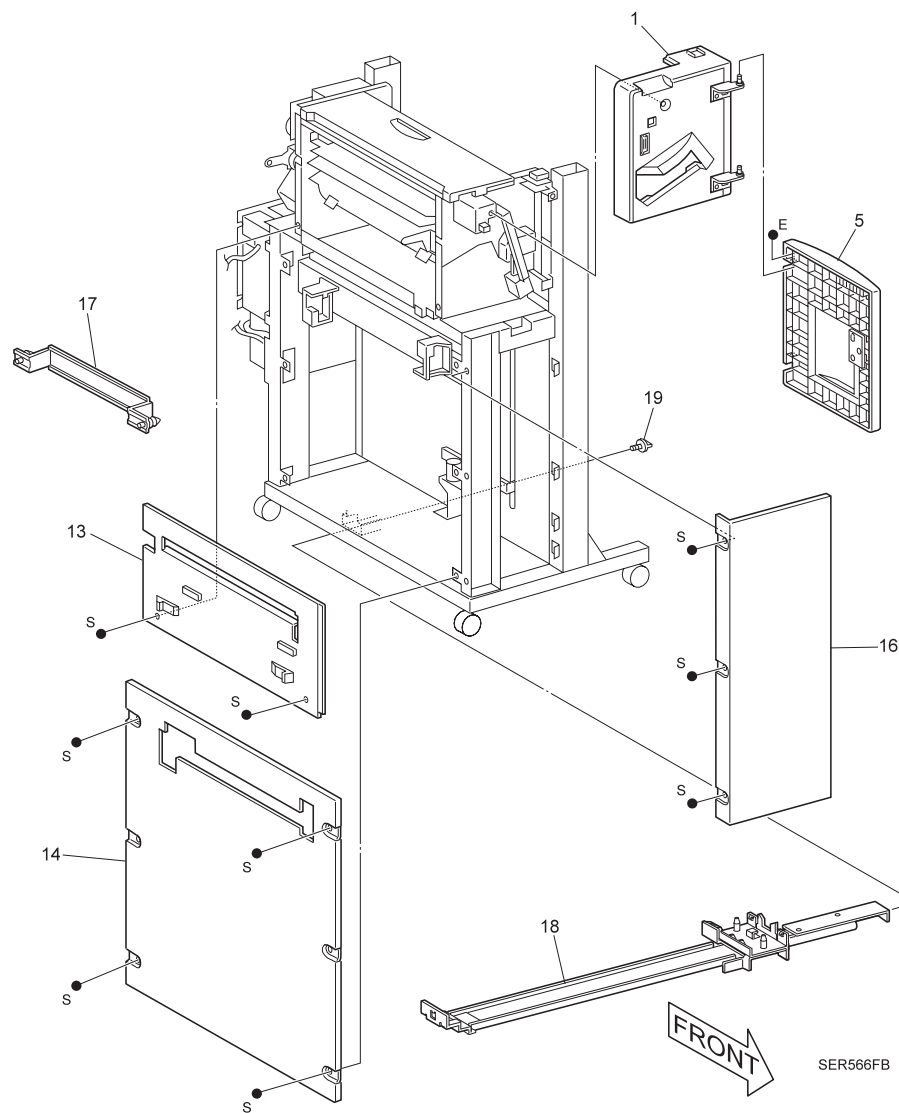
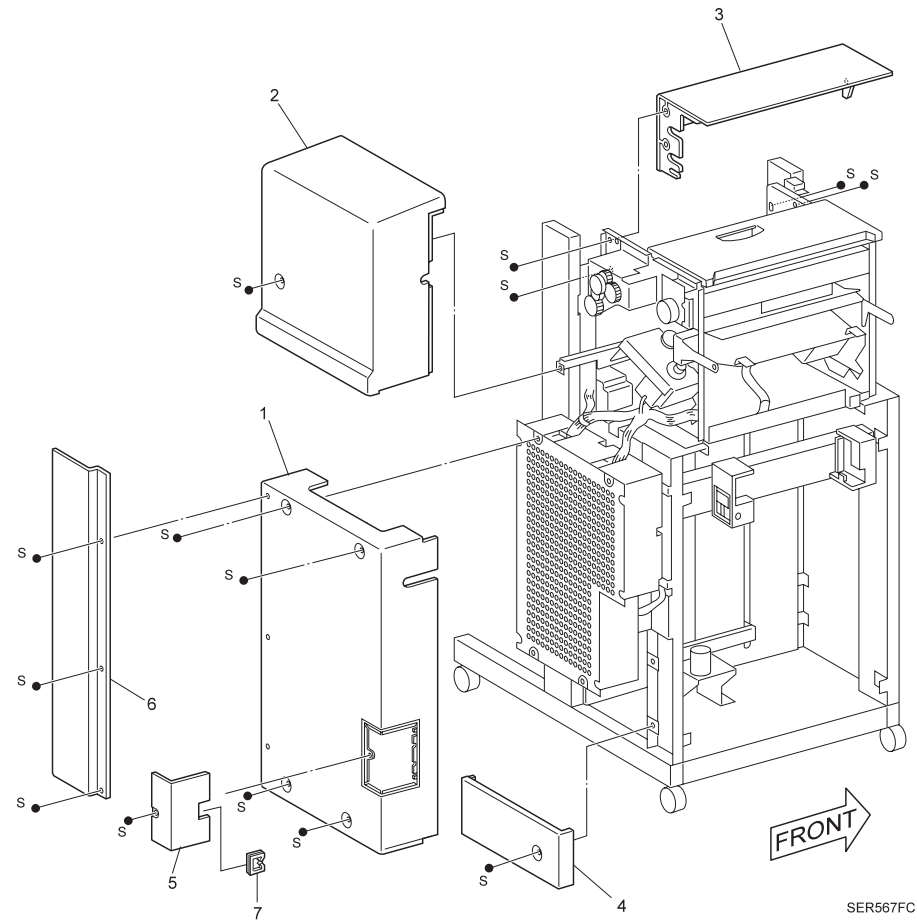

Figure 4-25. HCS Covers Front

### 4.3.3 HCS Covers Rear

1. COVER ASSEMBLY PWB
2. COVER REAR
3. COVER EJECT
4. COVER ADD
5. COVER CONNECTOR
6. COVER HARNESS
7. CLAMP



SER567FC

Figure 4-26. HCS Covers Rear

### 4.3.4 Rack

1. --
2. COVER ASSEMBLY RACK R/H
3. SWITCH MICRO
4. --
5. CASTER
6. --
7. SUPPORT DOCKING
8. SENSOR
9. SUPPORT DOCKING
10. ACTUATOR
11. --
12. HARNESS
13. BRACKET SENSOR
14. --
15. HARNESS
16. HARNESS ASSEMBLY DC MAIN COM-2
17. HARNESS ASSEMBLY F-INTERLOCK SENSOR
18. HARNESS ASSEMBLY TRAY ID
19. PLATE SLIT
20. CASTER LOCK

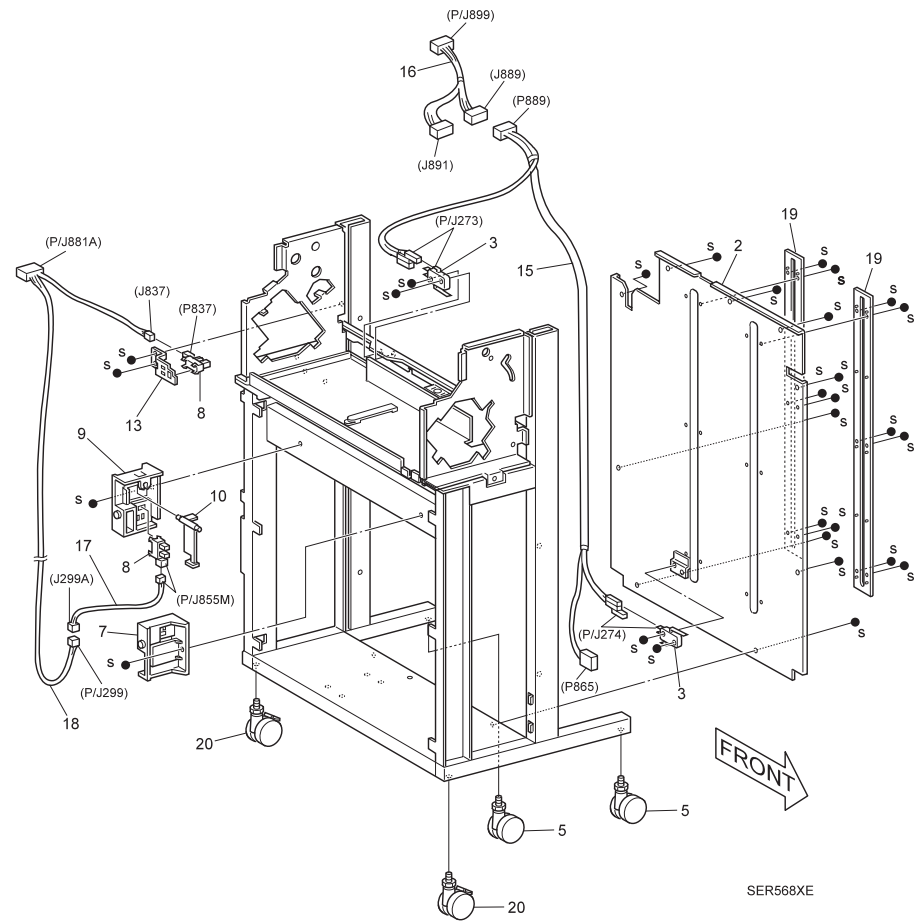

Figure 4-27. RACK



### 4.3.5 Rails and Trays

1. RAIL ASSEMBLY FRONT (with 2, 6, 7)
2. COVER RAIL
3. BRACKET TRAY REAR
4. - -
5. RAIL ASSEMBLY REAR (with 2, 3, 6)
6. RAIL ASSEMBLY
7. BRACKET TRAY FRONT
8. REFERENCE ONLY (Exploded on PL18.6)
9. REFERENCE ONLY (Exploded on PL18.4)
10. REFERENCE ONLY (Exploded on PL18.2)
11. MOTOR ASSEMBLY TRAY CHANGE (with 12 ~ 15, 30, 31)
12. BRACKET MOTOR ASSEMBLY CHANGE
13. GEAR 50Z/34T
14. PULLEY-14T
15. MOTOR ASSEMBLY - DC
16. GEAR DRIVE 37Z
17. BEARING
18. BRACKET DRIVE ELEV
19. NUT LIFT
20. SHAFT DRIVE
21. BEARING
22. COVER GUIDE TRAY
23. - -
24. PLATE TIE ELEV UP
25. GUIDE-HARNESS UP
26. CLAMP LOCKING
27. GUIDE-HARNESS BOTTOM
28. BRACKET HINGE ELEV
29. PLATE-TIE ELEV LOW
30. BELT
31. PLATE MOTOR CHANGE
32. GEAR 24Z-42Z
33. GUARD-FRONT
34. GUARD-REAR

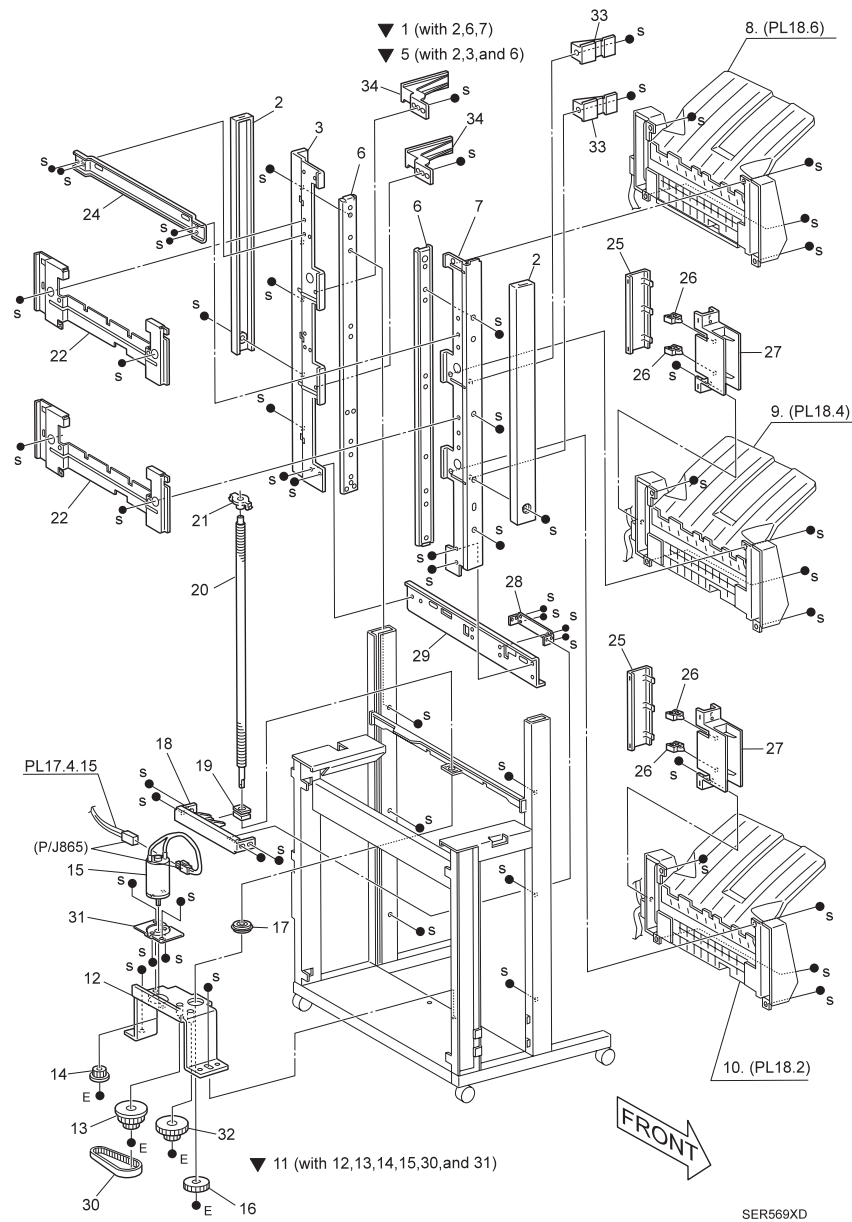

Figure 4-28. Rail and Trays

### 4.3.6 Lower Tray

1. TRAY ASSEMBLY LOWER (with 2~30, 34~36)
2. TRAY STACKER
3. ACTUATOR NO PAPER
4. SPRING TORSION
5. SENSOR PI, DH
6. BRACKET NO PAPER
7. --
8. --
9. SENSOR PI, DL
10. CARRIAGE ASSEMBLY (with 11, 12)
11. CARRIAGE
12. ROLL ELEV
13. COVER ELEV FRONT
14. REFERENCE ONLY (Exploded on PL18.3)
15. CLAMP
16. ACTUATOR LIMIT
17. MOTOR ASSEMBLY ELEV (with 18~20)
18. MOTOR ASSEMBLY -DC
19. BRACKET MOTOR ELEV
20. GEAR 20Z
21. --
22. --
23. --
24. --
25. SENSOR ASSEMBLY (with 5, 9, 27, 34)
26. --
27. BRACKET SENSOR ELEV
28. --
29. COVER ELEV REAR
30. COVER HARNESS REAR
31. --
32. HARNESS
33. --
34. GUIDE ACTUATOR
35. HARNESS ASSEMBLY LOW SENSOR COM
36. HARNESS ASSEMBLY LOW PAPER COM
98. KIT ELEV COVER REAR (29, 30)
99. KIT ELEV ROLLER (Qty 4 of item 12)

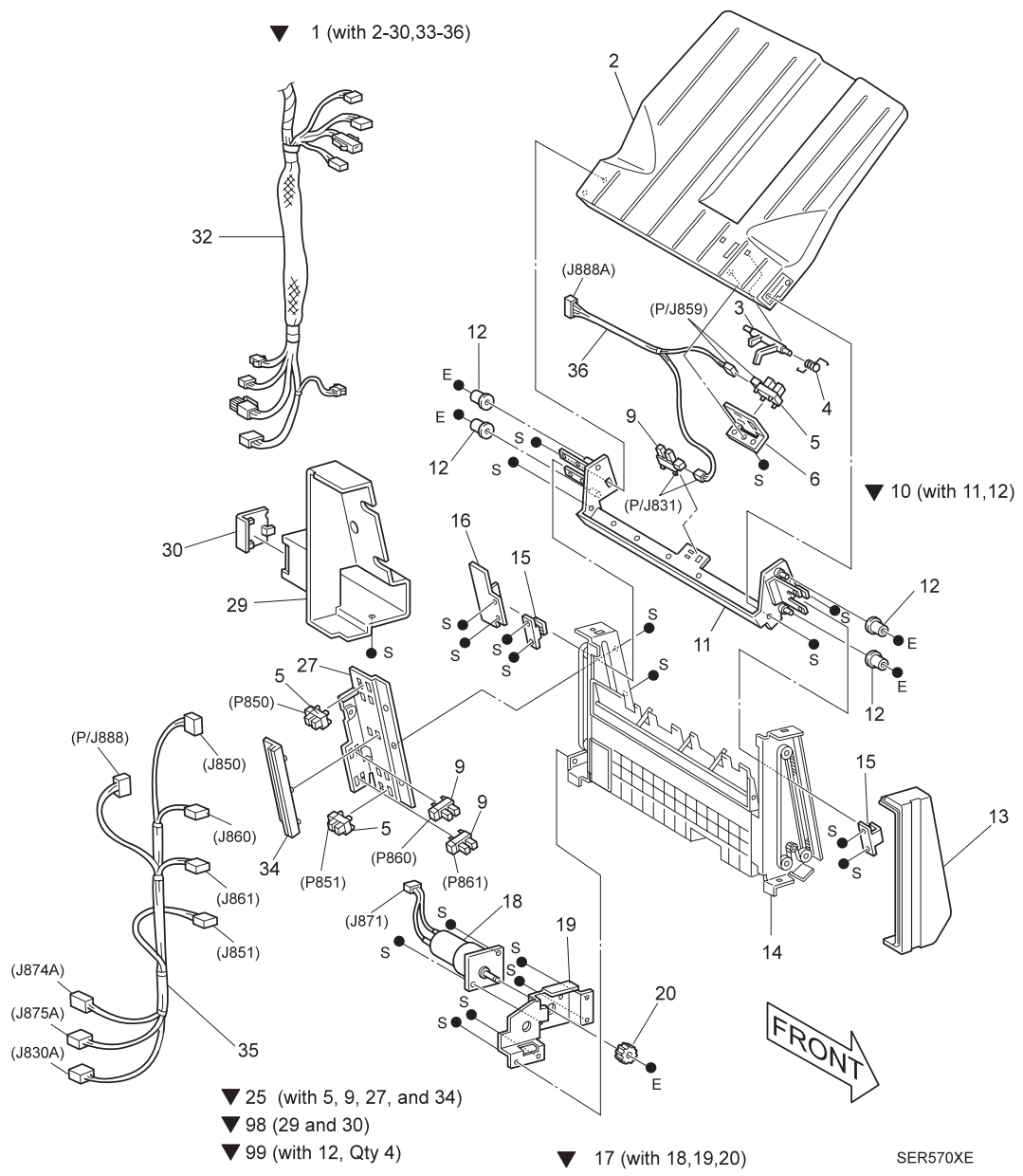

Figure 4-29. Lower Tray

### 4.3.7 Lower Tray Frame

1. GUIDE ASSEMBLY TRAY LOW (with 2~5)
2. GUIDE TRAY
3. STOPPER ASSEMBLY PAPER
4. SPRING TORSION
5. BEARING
6. FRAME ASSEMBLY ELEV FL
7. PULLEY IDL 20T
8. PLATE TENSION
9. SPRING EXIT
10. BELT
11. PULLEY DRV 18T
12. BEARING
13. SHAFT ELEV
14. --
15. --
16. GEAR SPUR 32Z
17. GEAR PULLEY 14Z/18T
18. GEAR SPUR 20Z
19. --
20. FRAME ASSEMBLY ELEV REAR
21. FLANGE-PULLEY, 6
22. SPACER

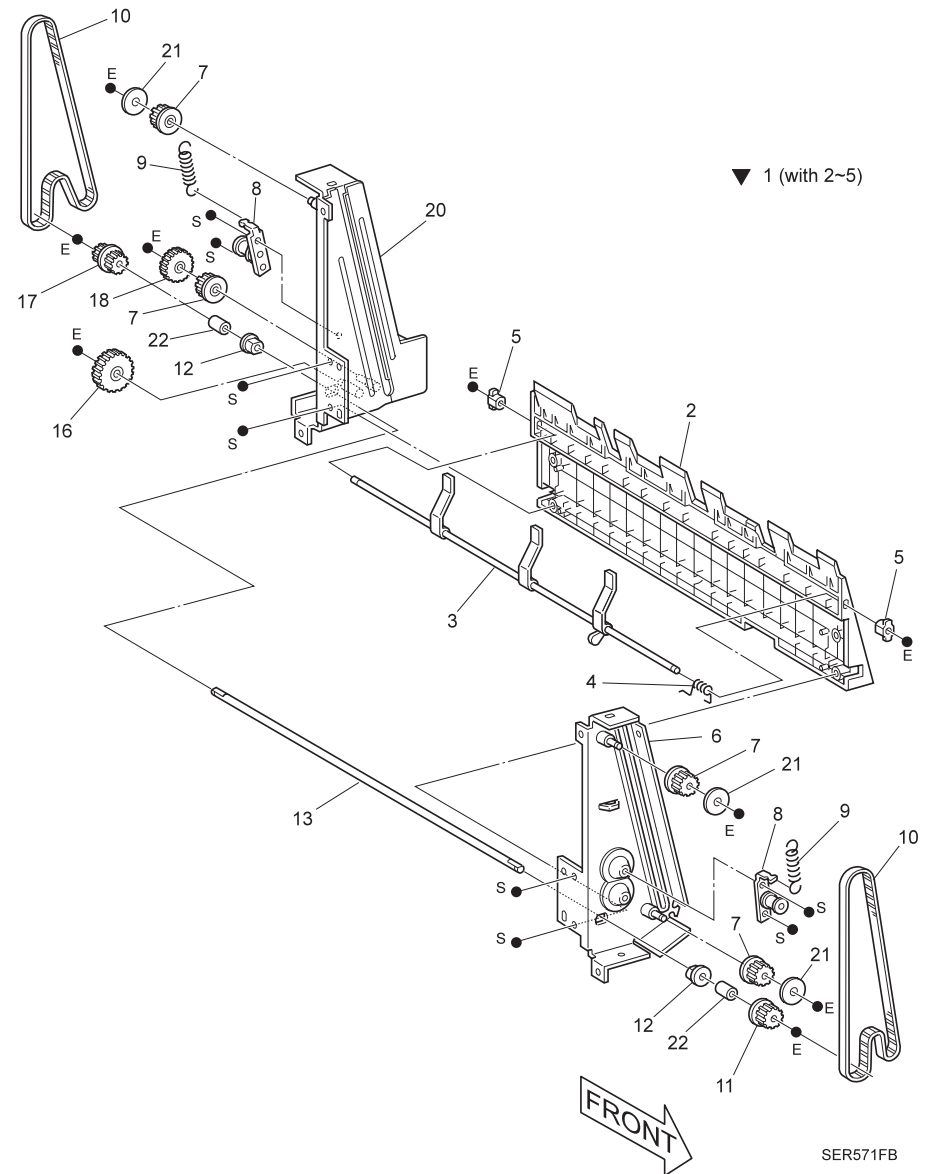

Figure 4-30. Lower Tray Frame

### 4.3.8 Middle Tray

1. TRAY ASSEMBLY MIDDLE (with 2~6, 10~20, 25~27, 29, 30, 34~36)
2. TRAY STACKER
3. ACTUATOR NO PAPER
4. SPRING TORSION
5. SENSOR PI, DH
6. BRACKET NO PAPER
7. --
8. --
9. --
10. CARRIAGE ASSEMBLY (with 11, 12)
11. CARRIAGE
12. ROLL ELEV
13. COVER ELEV FRONT
14. REFERENCE ONLY (Exploded on PL18.5)
15. CLAMP
16. ACTUATOR LIMIT
17. MOTOR ASSEMBLY ELEV (with 18~20)
18. MOTOR ASSEMBLY -DC
19. BRACKET MOTOR ELEV
20. GEAR 20Z
21. --
22. --
23. --
24. --
25. SENSOR ASSEMBLY ELEV (with 5, 26, 27, 34)
26. SENSOR PI, DL
27. BRACKET SENSOR ELEV
28. --
29. COVER ELEV REAR
30. COVER HARNESS REAR
31. --
32. --
33. --
34. GUIDE ACTUATOR
35. HARNESS ASSEMBLY MID SENSOR
36. HARNESS ASSEMBLY MID PAPER COM
98. KIT ELEV COVER REAR (29, 30)
99. KIT ELEV ROLLER (Qty 4 of item 12)

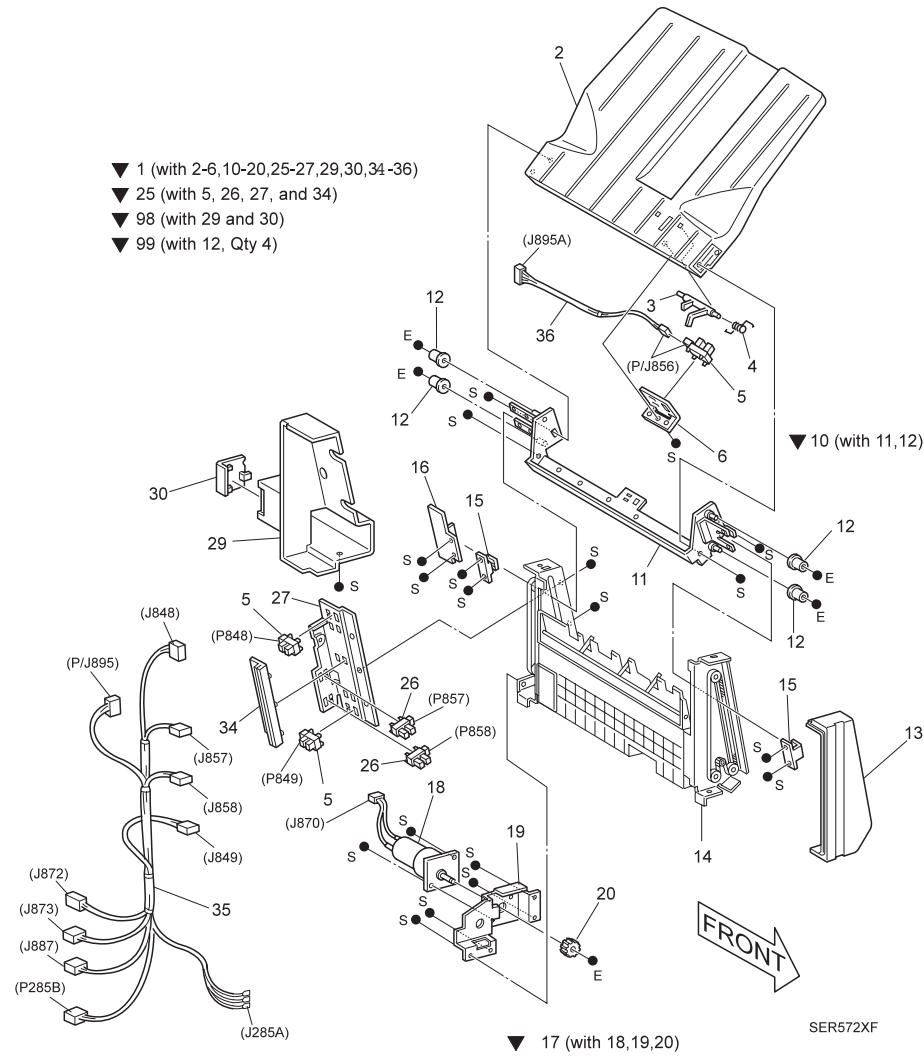

Figure 4-31. Middle Tray

### 4.3.9 Middle Tray Frame

1. GUIDE ASSEMBLY TRAY MIDDLE (with 2~5)
2. GUIDE TRAY
3. STOPPER ASSEMBLY PAPER
4. SPRING TORSION
5. BEARING
6. FRAME ASSEMBLY ELEV FL
7. PULLEY IDL 20T
8. PLATE TENSION
9. SPRING EXIT
10. BELT
11. PULLEY DRV 18T
12. BEARING
13. SHAFT ELEV
14. --
15. --
16. GEAR SPUR 32Z
17. GEAR PULLEY 14Z/18T
18. GEAR SPUR 20Z
19. --
20. FRAME ASSEMBLY ELEV REAR
21. --
22. SPRING EXIT
23. PLATE SHAFT
24. SCREW
25. SWITCH MICRO
26. LINK-IDL
27. LINK-PUSH
28. HARNESS
29. FLANGE-PULLEY, 6
30. SPACER



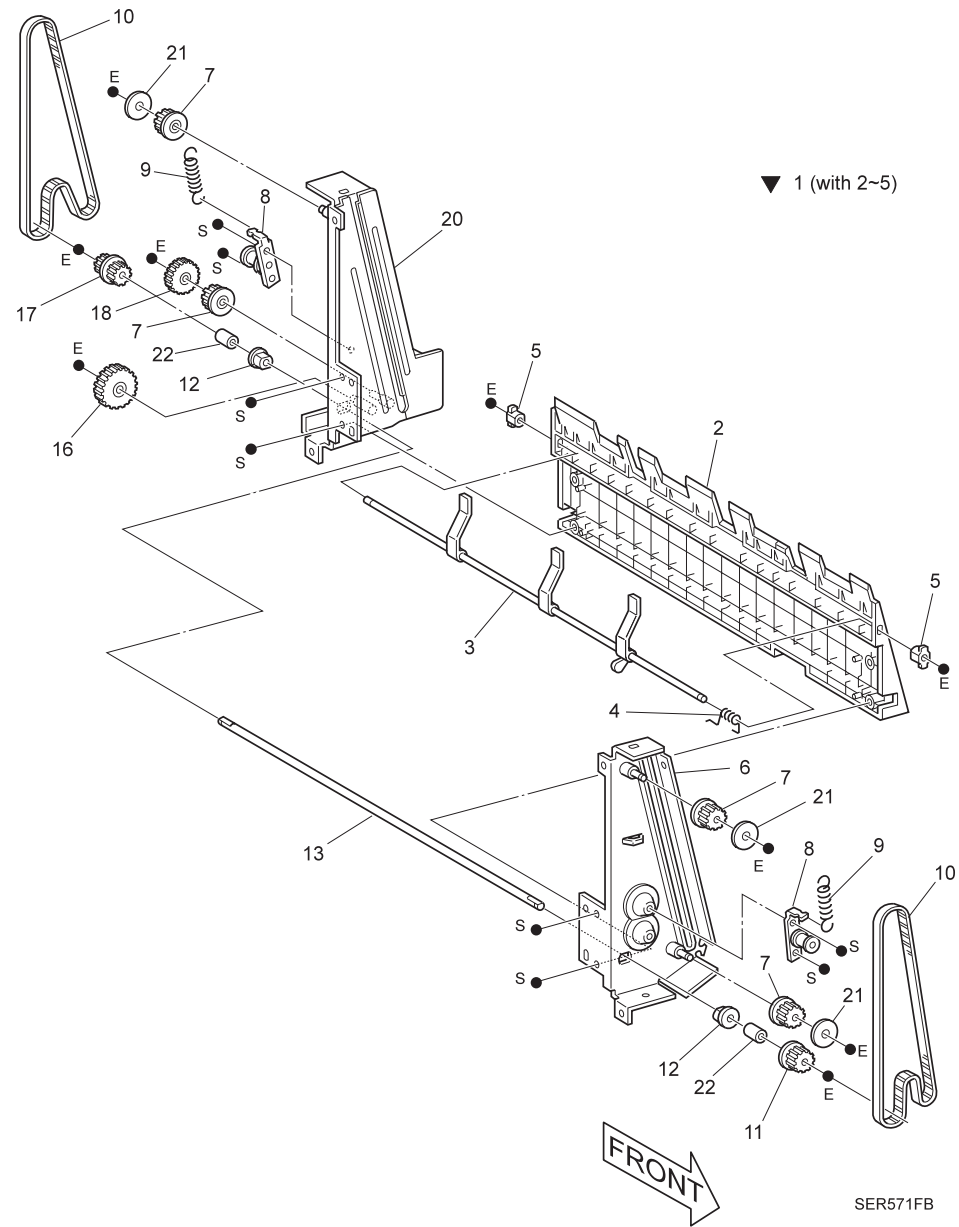

Figure 4-32. Middle Tray Frame

### 4.3.10 Top Tray

1. TRAY ASSEMBLY TOP (with 2~6, 10~20, 25~27, 29, 30, 34~36)
2. TRAY STACKER
3. ACTUATOR NO PAPER
4. SPRING TORSION
5. SENSOR PI, DH
6. BRACKET NO PAPER
7. --
8. --
9. --
10. CARRIAGE ASSEMBLY (with 11, 12)
11. CARRIAGE
12. ROLL ELEV
13. COVER ELEV FRONT
14. REFERENCE ONLY (Exploded on PL18.7)
15. CLAMP
16. ACTUATOR LIMIT
17. MOTOR ASSEMBLY ELEV (with 18~20)
18. MOTOR ASSEMBLY - DC
19. BRACKET MOTOR ELEV
20. GEAR 20Z
21. --
22. --
23. --
24. --
25. SENSOR ASSEMBLY (with 5, 26, 27, 34)
26. SENSOR PI, DL
27. BRACKET SENSOR ELEV
28. --
29. COVER ELEV REAR
30. COVER HARNESS REAR
31. --
32. --
33. --
34. GUIDE ACTUATOR
35. HARNESS ASSEMBLY TOP SENSOR
36. HARNESS ASSEMBLY TOP PAPER SENSOR
98. KIT ELEV COVER REAR (29, 30)
99. KIT ELEV ROLLER (Qty 4 of item 12)

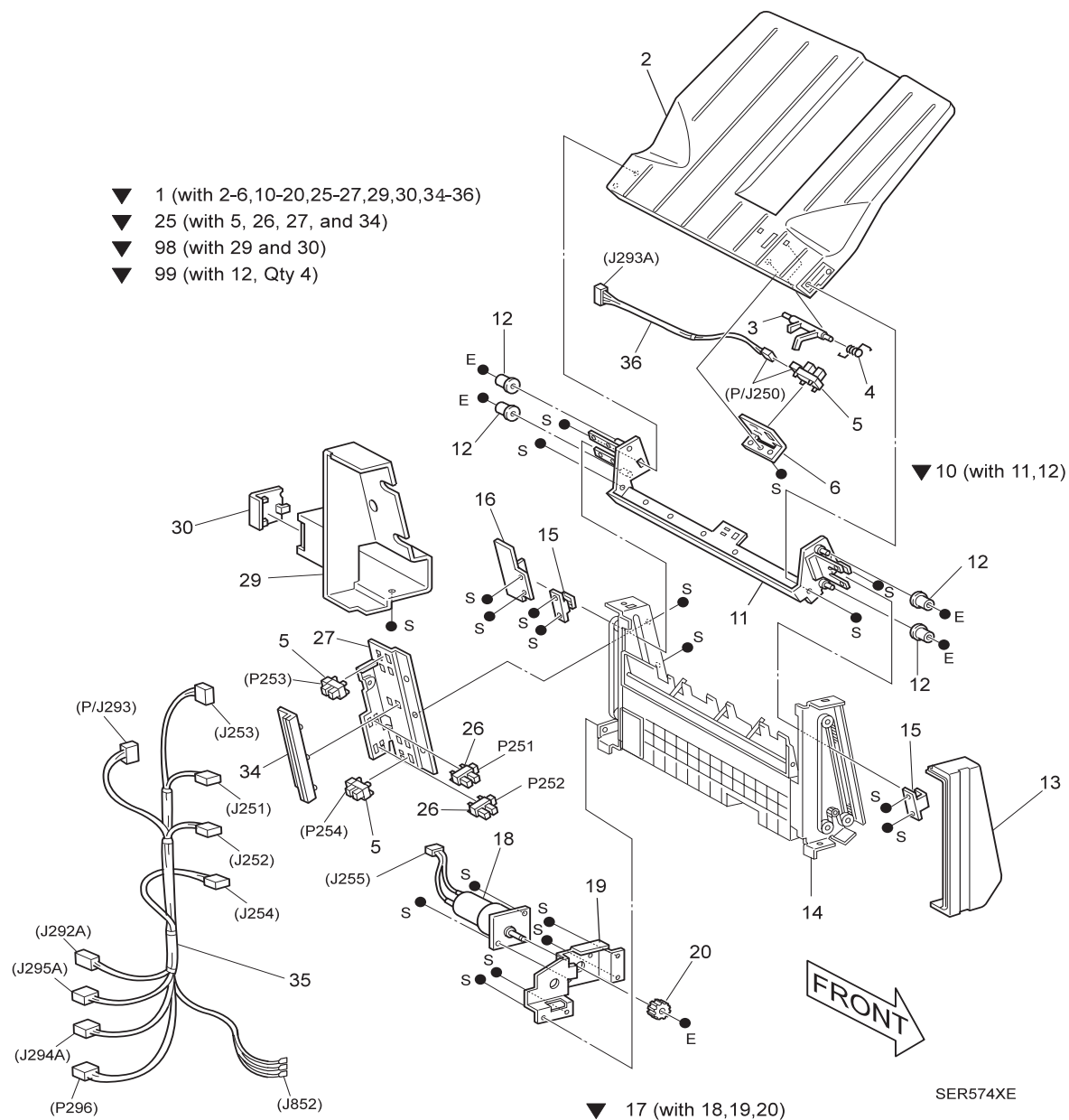

Figure 4-33. Top Tray

### 4.3.11 Top Tray Frame

1. GUIDE ASSEMBLY TRAY TOP (with 2~5)
2. GUIDE TRAY
3. STOPPER ASSEMBLY PAPER
4. SPRING TORSION
5. BEARING
6. FRAME ASSEMBLY ELEV FL
7. PULLEY IDL 20T
8. PLATE TENSION
9. SPRING EXIT
10. BELT
11. PULLEY DRV 18T
12. BEARING
13. SHAFT ELEV
14. --
15. --
16. GEAR SPUR 32Z
17. GEAR PULLEY 14Z/18T
18. GEAR SPUR 20Z
19. --
20. FRAME ASSEMBLY ELEV REAR
21. --
22. SPRINT EXIT
23. PLATE SHAFT
24. SCREW
25. SWITCH MICRO
26. LINK-IDL

27. LINK-PUSH
28. HARNESS
29. FLANGE-PULLEY, 6

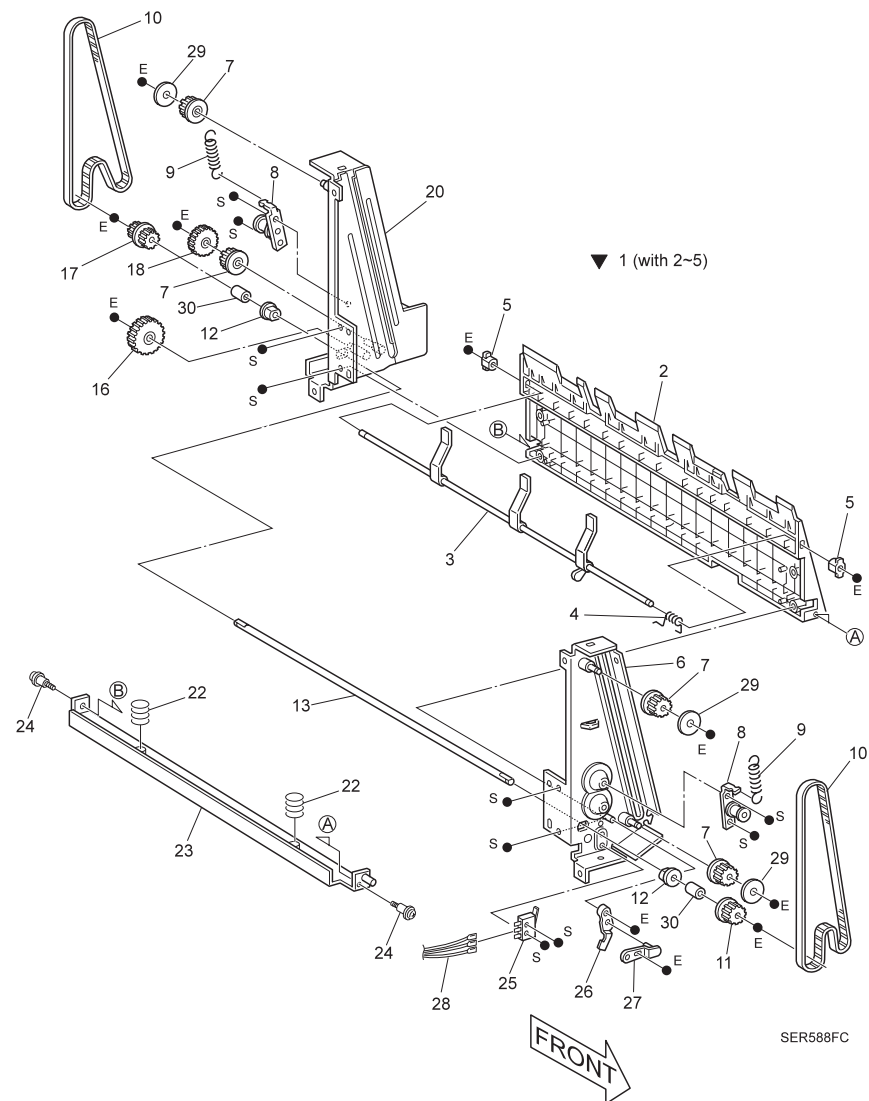

Figure 4-34. Top Tray Frame

### 4.3.12 Tray Eject

- |                            |                                   |
|----------------------------|-----------------------------------|
| 1. MOTOR ASSEMBLY - TAMPER | 27. --                            |
| 2. SPRING - TRAY           | 28. --                            |
| 3. SPRING - TAMPER         | 29. --                            |
| 4. SUPPORT - TAMPER        | 30. --                            |
| 5. GUIDE - TAMPER          | 31. BEARING                       |
| 6. --                      | 32. --                            |
| 7. BASE - TAMPER           | 33. SOLENOID ASSEMBLY             |
| 8. SENSOR PI, DH           | 34. --                            |
| 9. TRAY ASSEMBLY - COMP    | 35. --                            |
| 10. COVER - COMPILE        | 36. --                            |
| 11. ACTUATOR               | 37. --                            |
| 12. SENSOR PI, DL          | 38. GUIDE-REGI                    |
| 13. --                     | 39. BEARING                       |
| 14. BEARING                | 40. GEAR EJECT (Z-20)             |
| 15. SPRING - TENSION       | 41. LEVER ASSEMBLY - OFFSET       |
| 16. --                     | 42. PULLEY                        |
| 17. --                     | 43. ACTUATOR - SET CLAMP          |
| 18. --                     | 44. BRACKET ASSEMBLY              |
| 19. LINK - ENDWALL         | 45. SHAFT ASSEMBLY EJECT 1        |
| 20. --                     | 46. SHAFT ASSEMBLY EJECT 2        |
| 21. HOLDER - TAMPER        | 47. HARNESS ASSEMBLY COMPILER COM |
| 22. BELT SYNCHRONOUS       | 48. ROLLER                        |
| 23. HOLDER - BELT          | 49. CORE                          |
| 24. CHUTE EJECT, ROLL      |                                   |
| 25. GUIDE ASSEMBLY - END   |                                   |
| 26. --                     |                                   |

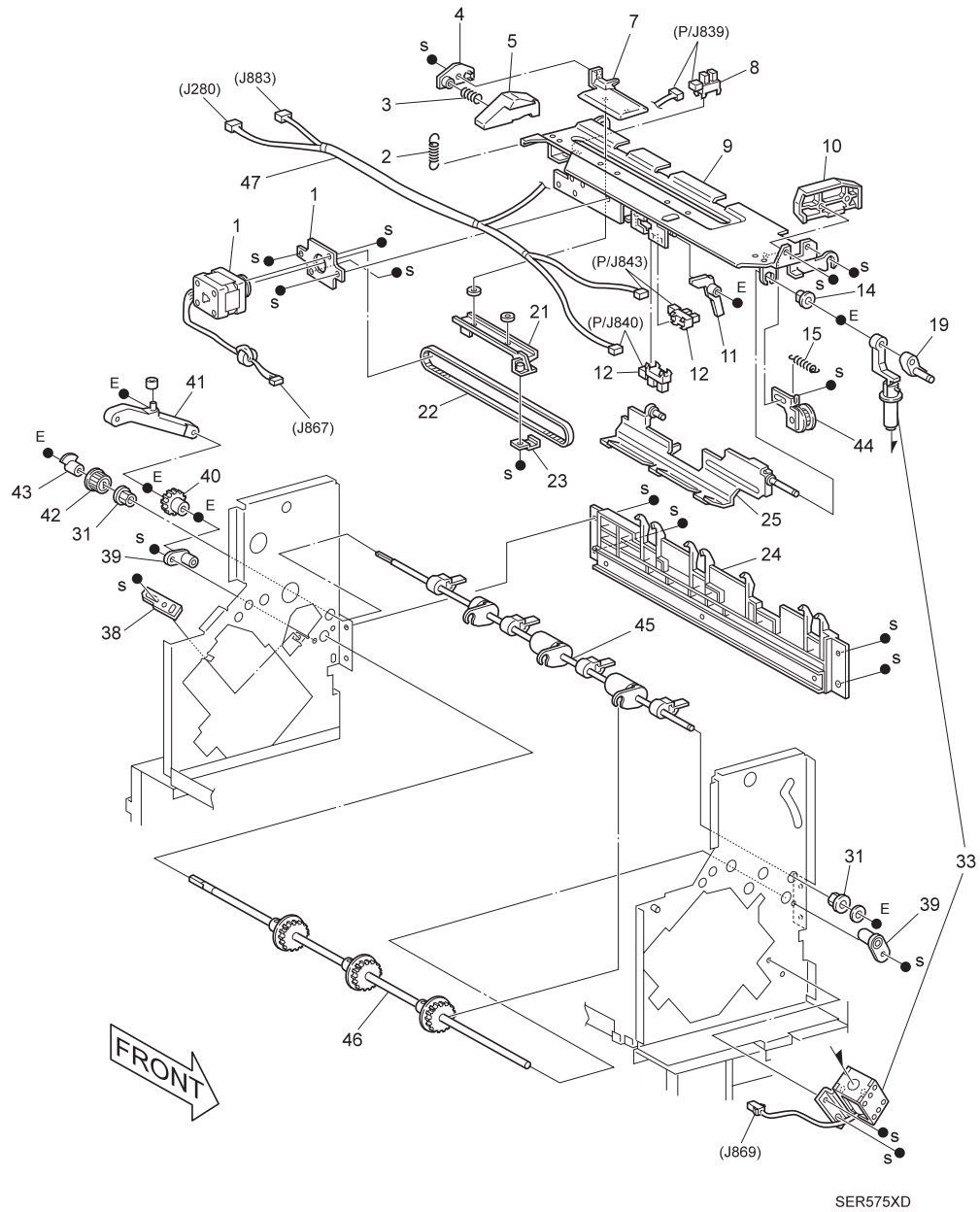

Figure 4-35. Tray Eject

### 4.3.13 Exit

1. CHUTE ASSEMBLY UPPER, EXIT (WITH 7~8, 21)
2. --
3. --
4. --
5. --
6. --
7. CHUTE - EXIT
8. SPRING GUIDE
9. SHAFT ASSEMBLY - EXIT
10. BEARING
11. CHUTE ASSEMBLY - LOWER, EXIT (with 12~19)
12. CHUTE ASSEMBLY EXIT
13. ROLLER ASSEMBLY
14. SPRING PINCH
15. BEARING PADDLE
16. SHAFT ASSEMBLY - PADDLE
17. PULLEY EXIT
18. BELT - SYNCHRONOUS
19. SHAFT ASSEMBLY - DRIVE, PADDLE
20. PLATE-TIE
21. ELIMINATOR

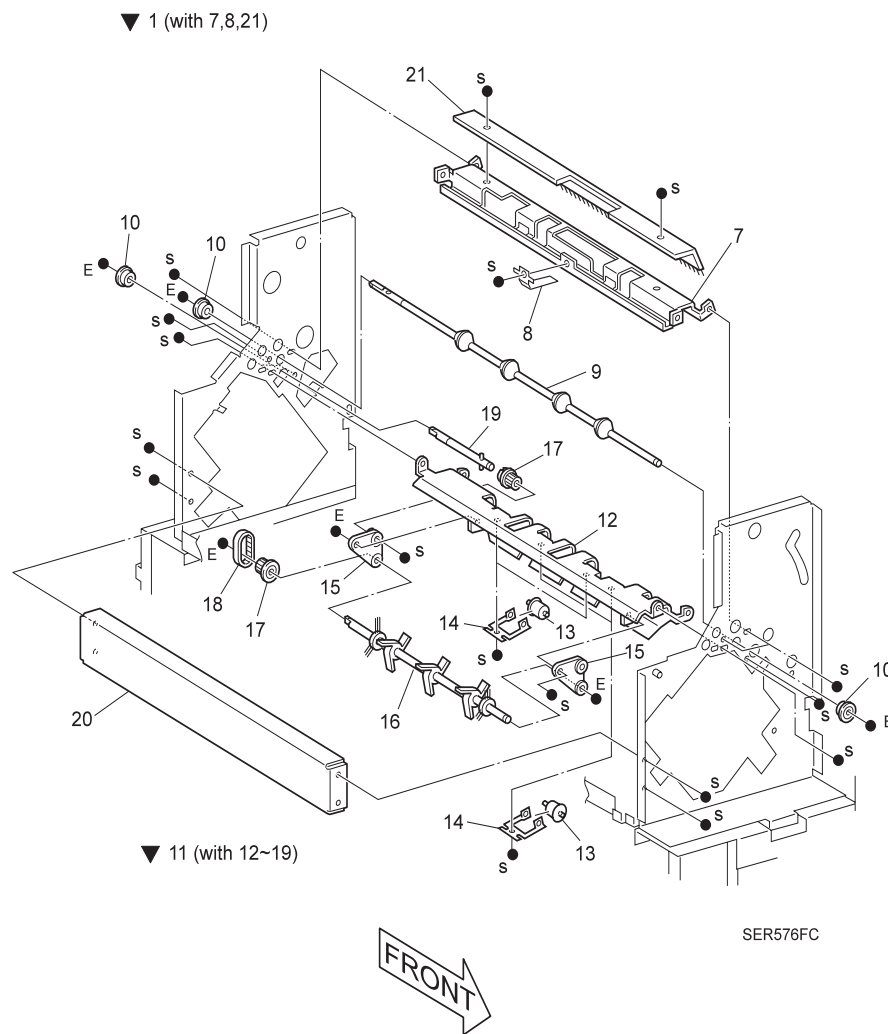

Figure 4-36. Exit





### 4.3.15 Stapler

1. STAPLER ASSEMBLY
2. --
3. HARNESS ASSEMBLY STAPLER HEAD COM
4. --
5. --
6. RAIL STAPLER (with 13, 14, 21)
7. --
8. --
9. --
10. --
11. --
12. --
13. SENSOR - PI, DH
14. BRACKET - SENSOR
15. --
16. --
17. --
18. --
19. --
20. --
21. HARNESS ASSEMBLY STAPLER SENSOR COM
22. CLAMP LOCKING

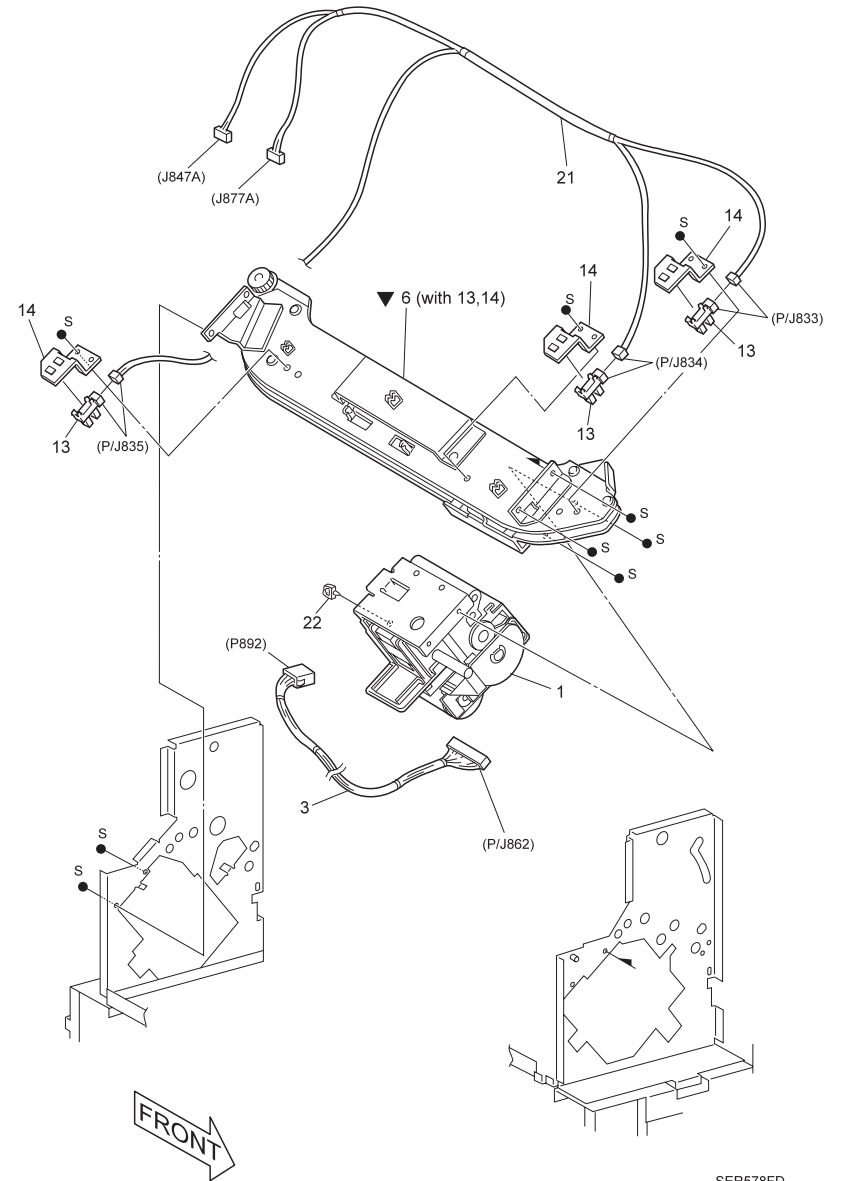

SER578FD

Figure 4-38. Stapler

### 4.3.16 Transport

1. COVER ASSEMBLY - TOP
2. LINK - TENSION
3. PLATE - TIE
4. FRAME ASSEMBLY - REAR
5. BEARING
6. --
7. SHAFT ASSEMBLY - TRANSPORT
8. CHUTE ASSEMBLY - LOWER
9. CHUTE ASSEMBLY - UPPER, TRANSPORT (with 11~13, 15, 16)
10. --
11. SENSOR ASSEMBLY
12. CHUTE ASSEMBLY - TRANSPORT
13. MAGNET CATCH
14. --
15. SPRING - PINCH TRANSPORT
16. ROLL - PINCH
17. BRACKET HINGE
18. FRAME ASSEMBLY - FRONT
19. BRACKET
20. SCREW SL DEL M3X2X6
21. HARNESS ASSEMBLY COMP. EXIT SENSOR

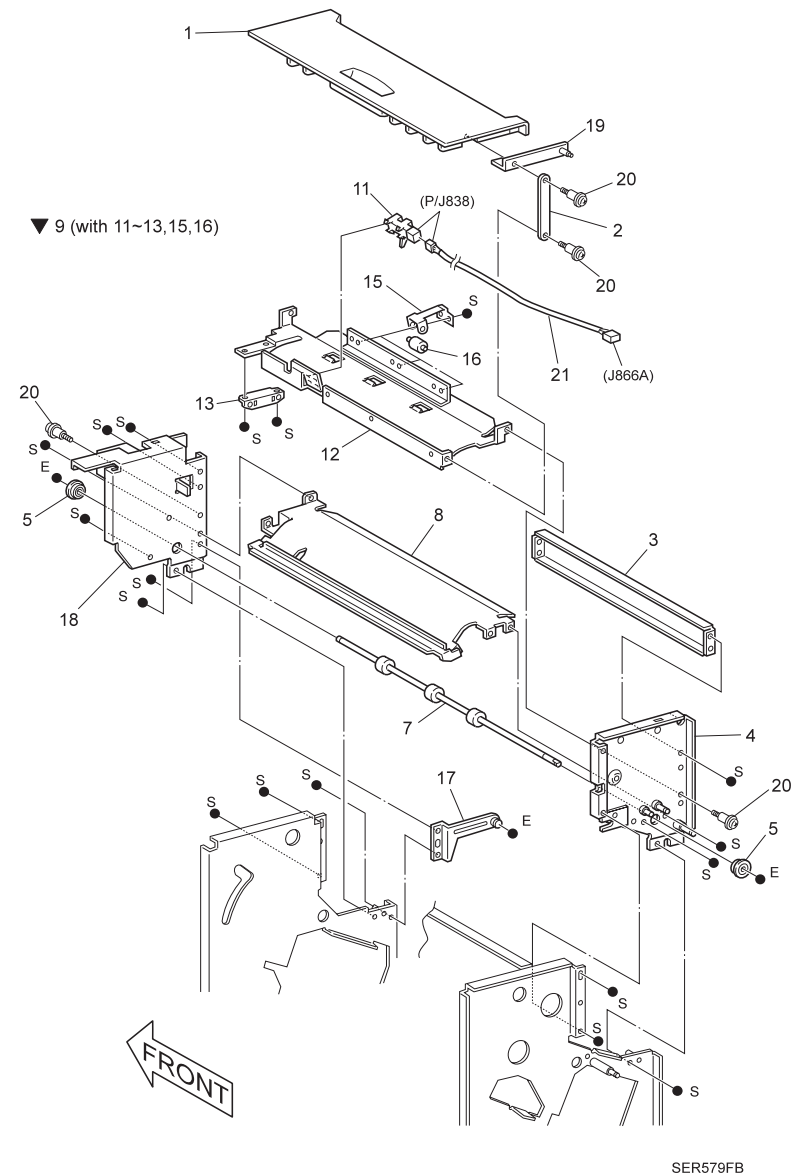
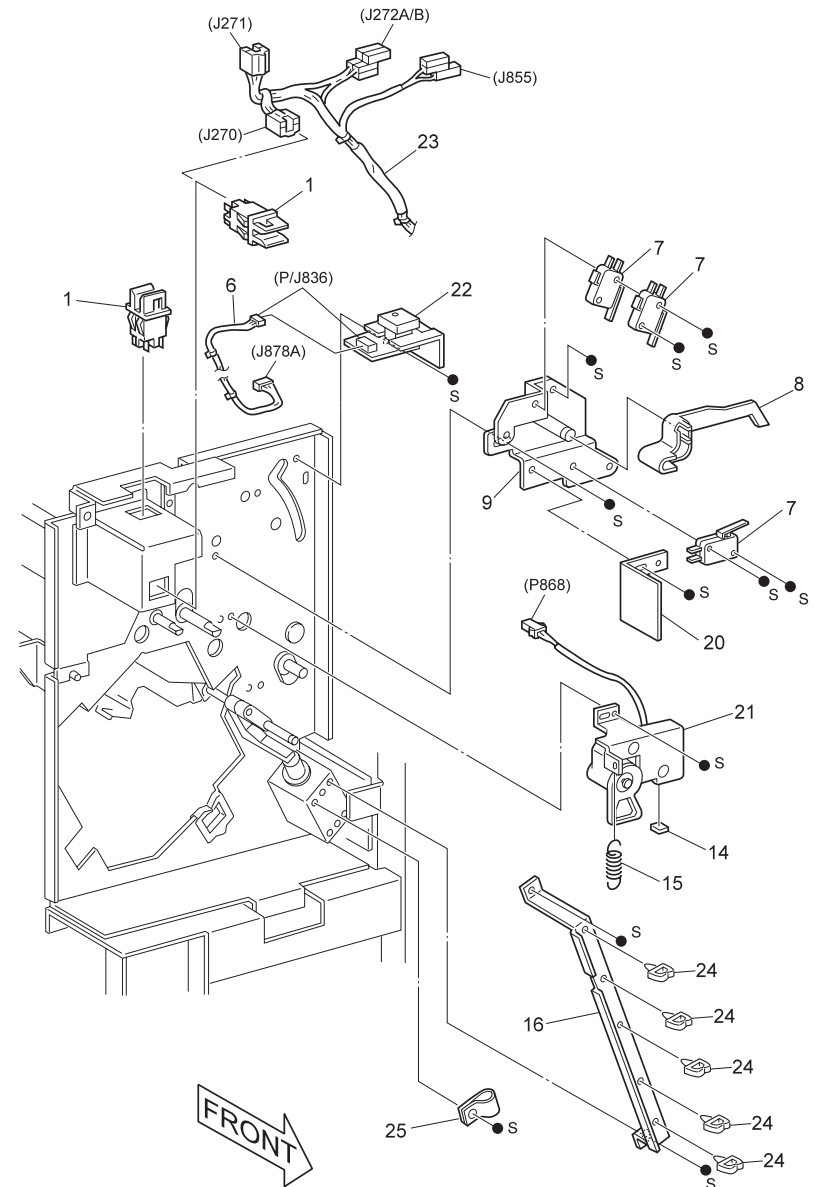

Figure 4-39. Transport

### 4.3.17 Front Frame

1. SWITCH
2. --
3. --
4. --
5. --
6. HARNESS ASSEMBLY - LED SWITCH
7. SWITCH - MICRO
8. ACTUATOR - INTERLOCK
9. BRACKET ASSEMBLY
10. --
11. --
12. --
13. --
14. DAMPER
15. SPRING - ENDWALL
16. HOLDER HARNESS
17. --
18. --
19. --
20. BRACKET
21. MOTOR ASSEMBLY - END WALL
22. SWITCH ASSEMBLY
23. HARNESS ASSEMBLY INTERLOCK M
24. CLAMP
25. CLAMP-P



SER580FD

Figure 4-40. Front Frame

### 4.3.18 Rear Frame 1

1. MOTOR ASSEMBLY - TRANSPORT
2. CLAMP
3. BRACKET
4. --
5. MOTOR ASSEMBLY - DC
6. BRACKET MOTOR
7. BELT SYNCHRONOUS
8. PULLEY (23T)
9. BELT SYNCHRONOUS
10. PULLEY - EJECT (20T, Z-22)
11. SENSOR - PI, DL
12. MOTOR ASSEMBLY - STEPPING
13. BRACKET - MOTOR
14. MOTOR ASSEMBLY - STEPPING
15. BELT SYNCHRONOUS
16. BRACKET MOTOR STAPLER

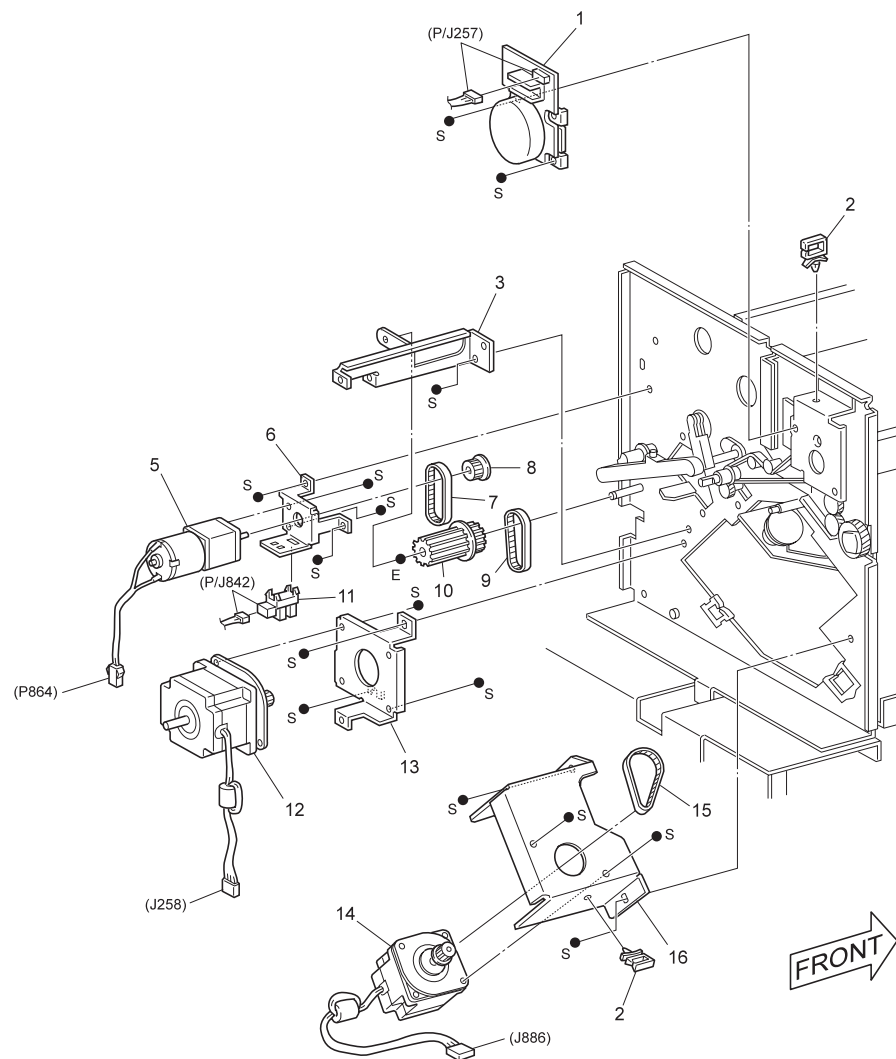

SER581FA

Figure 4-41. Rear Frame 1



### 4.3.20 Rear Frame 3

1. BRACKET ASSEMBLY - EJECT (with 2~27, 32)
2. MOTOR ASSEMBLY DC
3. HARNESS ASSEMBLY REAR COM
4. BRACKET - SENSOR CLAMP
5. SENSOR - PI, DH
6. SENSOR - PI, DL
7. --
8. BRACKET - SENSOR, OFFSET
9. --
10. SPRING - CLAMP CAM
11. CLAMP
12. GEAR
13. GEAR Z56(H), Z12
14. --
15. BEARING
16. GEAR ASSEMBLY - ONEWAY
17. --
18. ACTUATOR - EJECT CLAMP
19. CAM - EJECT CLAMP
20. SHAFT ASSEMBLY CLAMP
21. CAM - OFFSET + ACTUATOR - OFFSET
22. SHAFT ASSEMBLY OFFSET
23. SPRING
24. --
25. LEVER - CLAMP UP
26. SHAFT - CLAMP UP

27. BRACKET ASSEMBLY
28. --
29. BRACKET HARNESS
30. EDGE SADDLE
31. CLAMP
32. SPRING - CLAMP UP

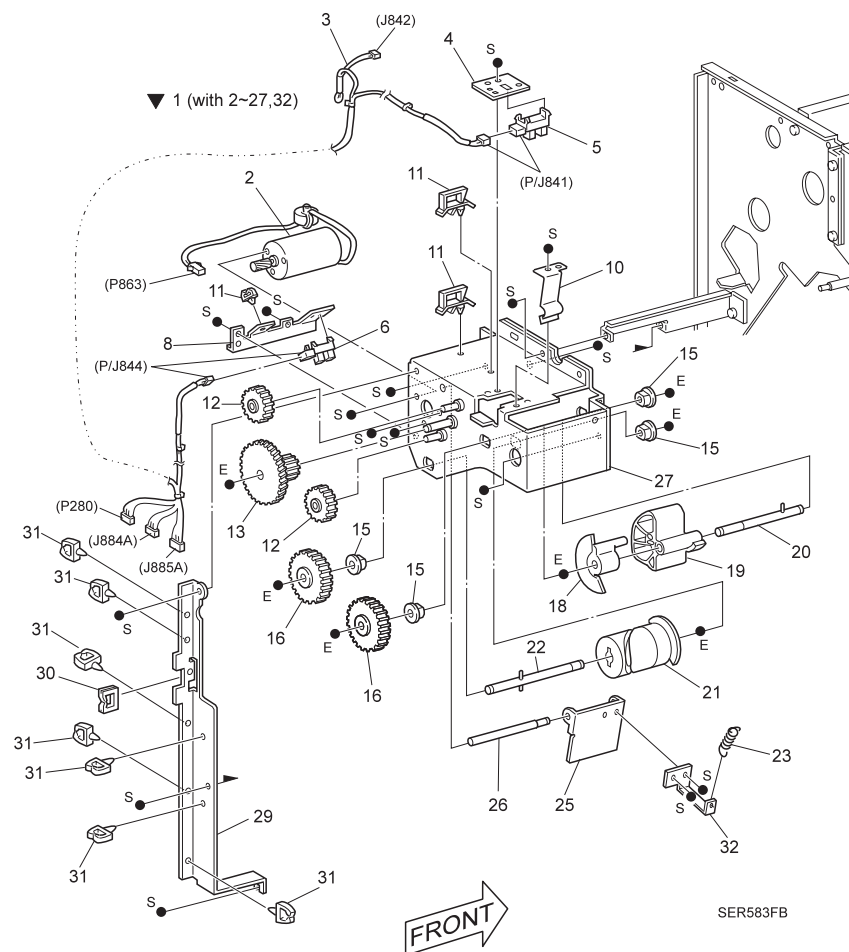

Figure 4-43. Rear Frame 3

### 4.3.21 Electrical Module

1. COVER TOP PWBA
2. PWB ASSEMBLY - FIN
3. BRACKET PWBA LVPS
4. PSLV - OP11/PSLV-OPR4H
5. --
6. HARNESS ASSEMBLY AC IN-OUT
7. --
8. CLAMP
9. --
10. CLAMP
11. PWB - SUPPORT PROTRUDE
12. --
13. --
14. CLAMP LOCKING
15. HOUSING

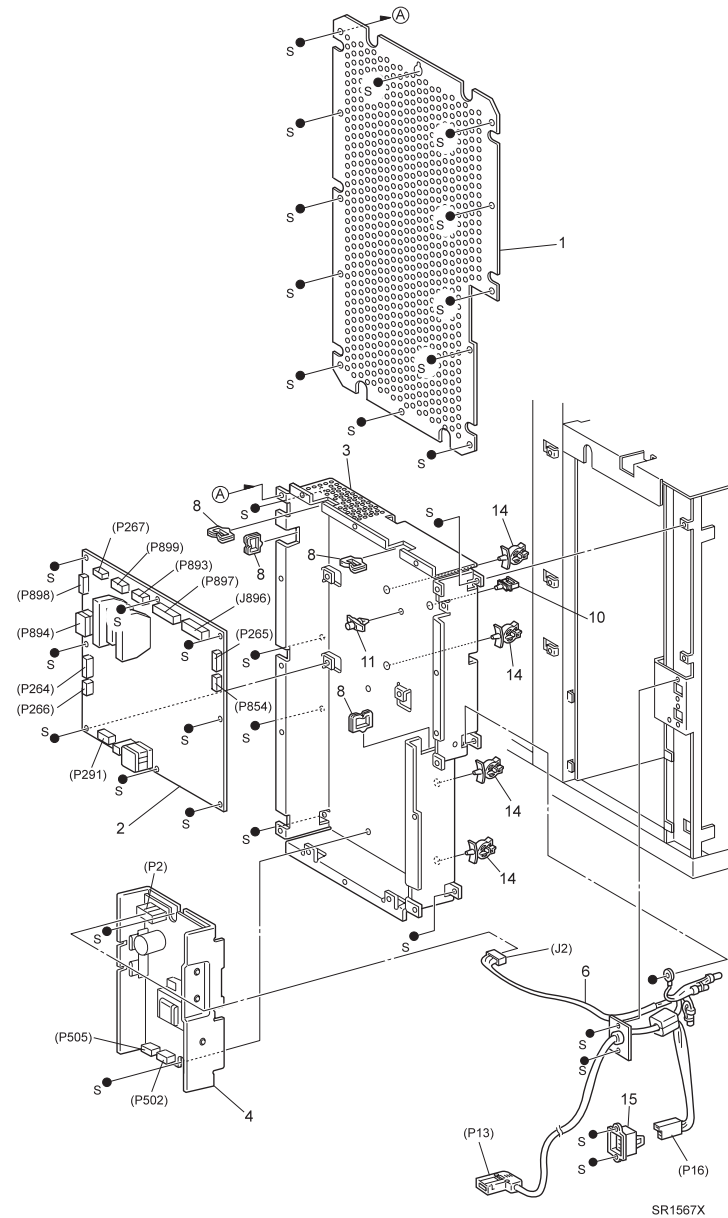

Figure 4-44. Electrical Module





### 4.3.23 HCS DOC

1. COVER ASSEMBLY - DOC, IOT
2. SUPPORT ASSEMBLY - GATE, IN (with 3~10)
3. CHUTE UPPER
4. GATE IN
5. SUPPORT GATE IN
6. ACTUATOR GATE IN
7. LEVER GATE IN
8. SPRING GATE IN
9. DAMPER SUPPORT 1
10. DAMPER SUPPORT 2

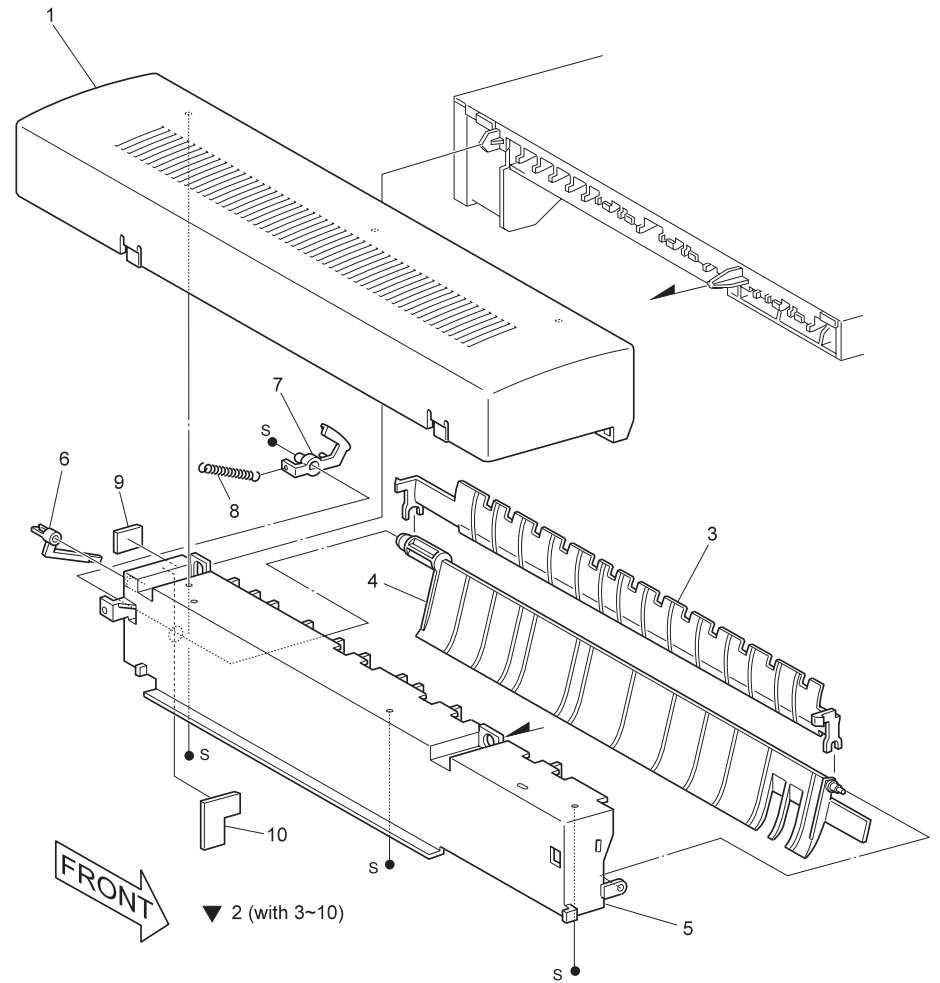

SER585FB

Figure 4-46. HCS DOC

### 4.3.24 Frame Transport, Rear

1. COVER REAR
2. --
3. BRACKET ASSEMBLY DRIVE
4. GEAR IDLE R
5. SUPPORT ASSEMBLY GEAR IDLE HT
6. GEAR IDLE L
7. SPRING GEAR 250
8. GEAR PULLEY 32/26
9. BELT - SYNC
10. PULLEY
11. BRACKET - ASSEMBLY TENSION
12. PULLEY 2
13. SPRING TENSION 80
14. SOLENOID ASSEMBLY
15. LINK ASSEMBLY DAMPER
16. ROLLER UNIT
17. SENSOR - PI, DL
18. BRACKET ASSEMBLY
19. CLAMP SADDLE
20. COVER ASSEMBLY SOLENOID
21. BRACKET ASSEMBLY DAMPER
22. SPRING PLATE
23. SPRING SOLENOID
24. HARNESS ASSEMBLY H-TRA SENSOR 1
25. HARNESS ASSEMBLY H-TRA SENSOR 2
26. HARNESS EARTH

98. KIT TRANSPORT GEAR (with 4 ~ 8)

99. KIT GATE SOLENOID (with 14, 15, 20)

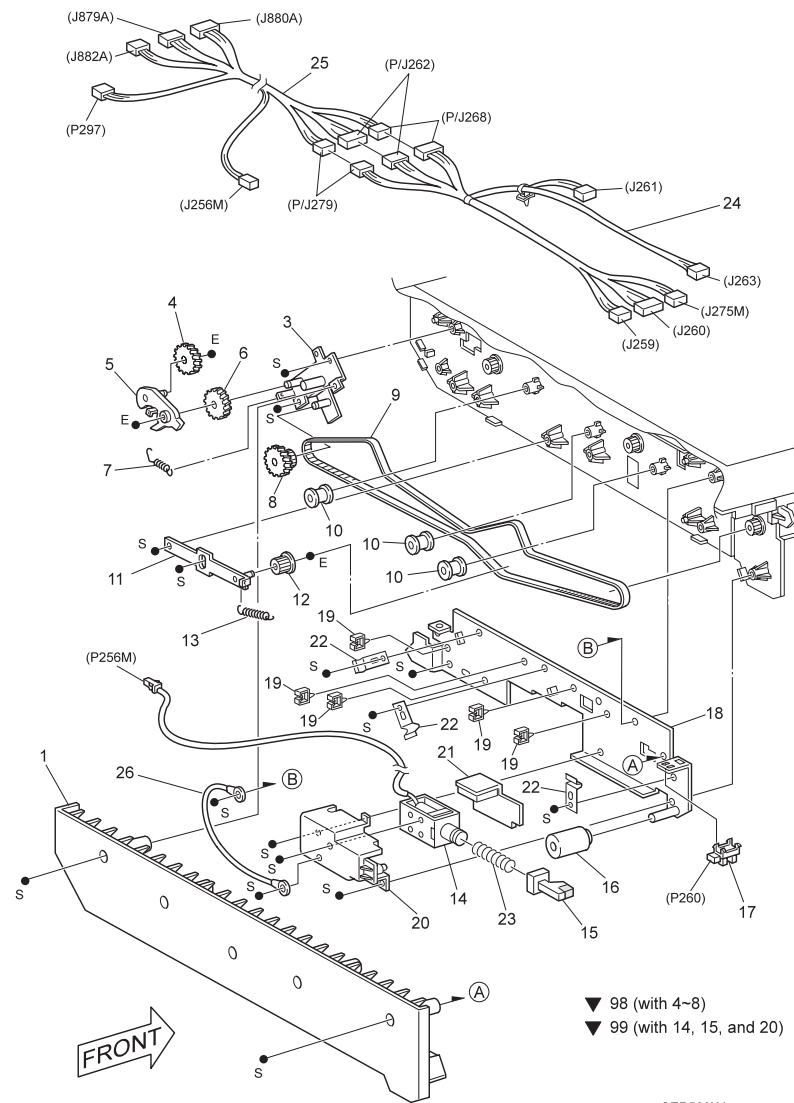

- ▼ 98 (with 4~8)
- ▼ 99 (with 14, 15, and 20)

SER586XJ

Figure 4-47. Frame Transport, Rear

### 4.3.25 Frame Transport, Open

1. COVER ASSEMBLY - OPEN (with 2~5)
2. COVER ASSEMBLY - OPEN
3. SPRING PINCH, OPEN
4. ROLL - PINCH
5. MAGNET 1.5
6. HARNESS ASSEMBLY H-TRA SENSOR 1
7. PLATE SENSOR, PHOTO
8. GUIDE ROLL, TRANSPORT
9. COVER SENSOR, PASS
10. ROLL TRANSPORT
11. SUPPORT - LH COVER
12. BRACKET PASS SENSOR
13. SENSOR ASSEMBLY
14. COVER SENSOR, FULL
15. PULLEY - ONEWAY
16. BEARING
17. COVER CHUTE
18. BEARING
19. SENSOR
20. --
21. BRACKET MAGNET
22. SENSOR ASSEMBLY
23. SPRING - PINCH
24. ROLL - PINCH
25. FRAME ASSEMBLY - TRANSPORT
26. SHAFT - TRANSPORT

27. SHAFT - TRANSPORT
28. CLAMP MINI CLAMP
29. SENSOR PI, PL
30. LEVER SUPPORT
31. DAMPER

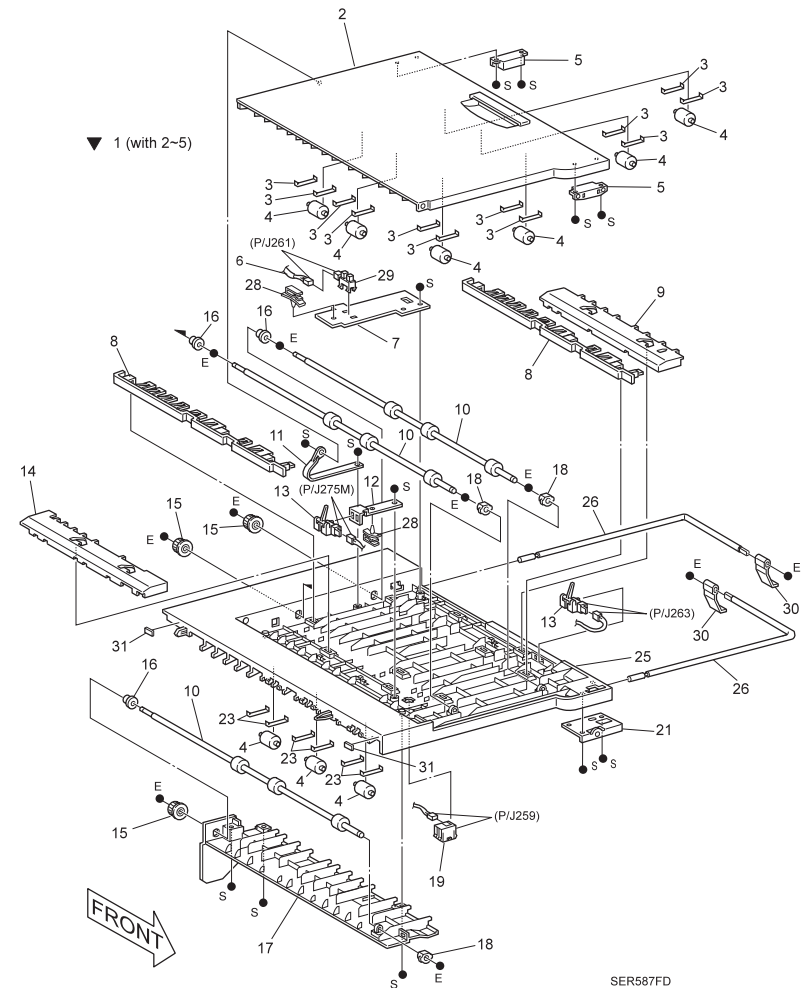

Figure 4-48. Frame Transport, Open